

# Bailey<sup>®</sup> network 90<sup>®</sup>

## Management Command System Hardware Manual Software Release K.0



**Product Instruction**

**E93-901-23**

**WARNING** notices as used in this manual apply to hazards or unsafe practices which could result in personal injury or death.

**CAUTION** notices apply to hazards or unsafe practices which could result in property damage.

**NOTES** highlight procedures and contain information which assist the operator in understanding the information contained in this manual.

## **WARNING**

### **INSTRUCTION MANUALS**

DO NOT INSTALL, MAINTAIN OR OPERATE THIS EQUIPMENT WITHOUT READING, UNDERSTANDING AND FOLLOWING THE PROPER **Bailey Controls** INSTRUCTIONS AND MANUALS, OTHERWISE INJURY OR DAMAGE MAY RESULT.

### **RADIO FREQUENCY INTERFERENCE**

MOST ELECTRONIC EQUIPMENT IS INFLUENCED BY RADIO FREQUENCY INTERFERENCE (RFI). CAUTION SHOULD BE EXERCISED WITH REGARD TO THE USE OF PORTABLE COMMUNICATIONS EQUIPMENT IN THE AREA AROUND SUCH EQUIPMENT. PRUDENT PRACTICE DICTATES THAT SIGNS SHOULD BE POSTED IN THE VICINITY OF THE EQUIPMENT CAUTIONING AGAINST THE USE OF PORTABLE COMMUNICATIONS EQUIPMENT.

### **POSSIBLE PROCESS UPSETS**

MAINTENANCE MUST BE PERFORMED ONLY BY QUALIFIED PERSONNEL AND ONLY AFTER SECURING EQUIPMENT CONTROLLED BY THIS PRODUCT. ADJUSTING OR REMOVING THIS PRODUCT WHILE IT IS IN THE SYSTEM MAY UPSET THE PROCESS BEING CONTROLLED. SOME PROCESS UPSETS MAY CAUSE INJURY OR DAMAGE.

## **AVERTISSEMENT**

### **MANUELS D'OPERATION**

NE PAS METTRE EN PLACE, REPARER OU FAIRE FONCTIONNER CE MATERIEL SANS AVOIR LU, COMPRIS ET SUIVI LES INSTRUCTIONS REGLIMENTAIRES DE **Bailey Controls** TOUTE NEGLIGENCE A CET EGARD POURRAIT ETRE UNE CAUSE D'ACCIDENT OU DE DEFAILLANCE DU MATERIEL.

### **PERTURBATIONS DE LA FREQUENCE RADIOPHONIQUE**

LA PLUPART DES EQUIPEMENTS ELECTRONIQUES SONT SENSIBLES AUX PERTURBATIONS DE LA FREQUENCE RADIO. DES PRECAUTIONS DEVRONT ETRE PRISES LORS DE L'UTILISATION DE MATERIEL DE COMMUNICATION PORTATIF. LA PRUDENCE EXIGE QUE LES PRECAUTIONS A PRENDRE DANS CE CAS SOIENT SIGNALEES AUX ENDROITS VOULOUS DANS VOTRE USINE.

### **PERTES PROCEDE RENVERSEMENTS**

L'ENTRETIEN DOIT ETRE ASSURE PAR UN PERSONNEL QUALIFIE ET EN CONSIDERATION DE L'ASPECT SECURITAIRE DES EQUIPEMENTS CONTROLES PAR CE PRODUIT. L'ADJUSTEMENT ET/OU L'EXTRACTION DE CE PRODUIT LORSQU'IL EST INSERE A UN SYSTEME ACTIF PEUT OCCASIONNER DES A-COUPS AU PROCEDE CONTROLE. SUR CERTAINS PROCEDES, CES A-COUPS PEUVENT EGALEMENT OCCASIONNER DES DOMMAGES OU BLESSURES.

## **NOTICE**

The information contained in this document is subject to change without notice.

Bailey Controls Company, its affiliates, employees, and agents, and the authors of and contributors to this publication specifically disclaim all liabilities and warranties, express and implied (including warranties of merchantability and fitness for a particular purpose), for the accuracy, currency, completeness, and/or reliability of the information contained herein and/or for the fitness for any particular use and/or for the performance of any material and/or equipment selected in whole or part with the user of/ or in reliance upon information contained herein. Selection of materials and/or equipment is at the sole risk of the user of this publication.

This document contains proprietary information which is protected by copyright. All rights are reserved. No part of this document may be photocopied or reproduced without the prior written consent of **Bailey Controls Company**.

---

---

## Preface

This manual serves as a reference manual for the Management Command System. It includes standard jumper configurations, switch settings, and cable and wire connections for all internal components. This information is provided should existing setups be inadvertently changed or modules be replaced. **The hardware configuration as stated in this manual is based on the requirements of MCS Software Revision K.0.**

If problems encountered in the installation, set-up, or servicing of the MCS are not addressed by this manual, or you believe the material contains inaccuracies, notify your nearest Bailey service center or sales office of the problem and request assistance.

It is recommended that you read the entire manual before beginning installation and power-up of your MCS.

This revision provides information for MCS software revision K.0 only. For information on hardware setup requirements for revisions previous to K.0, refer to instruction E93-901-23A dated 3/87, MCS Disk Server Unit instruction E93-901-24 dated 11/87, and MCS Remote Electronics Driver Cabinet instruction E93-901-52 dated 7/87.

\_\_\_\_\_



# Table of Contents

	Page
<b>SECTION 1 - INTRODUCTION</b> .....	1-1
GENERAL INTRODUCTION .....	1-1
SECTION CONTENT .....	1-1
RELATED DOCUMENTS .....	1-2
MANAGEMENT COMMAND SYSTEM (NMCS02) - PHYSICAL DESCRIPTION .....	1-2
STANDARD MCS HARDWARE .....	1-2
NMCS02 - COMPONENT LOCATION .....	1-4
SPECIFICATIONS - NMCS02 .....	1-5
<b>SECTION 2 - INSTALLATION AND START-UP</b> .....	2-1
UNPACKING AND VISUAL INSPECTION .....	2-1
MCS INSTALLATION .....	2-1
<b>SECTION 3 - STANDARD HARDWARE</b> .....	3-1
MULTIBUS CARD CAGE - FRONT VIEW .....	3-2
MULTIBUS CARD CAGE - BACK VIEW .....	3-3
MULTIBUS CARD INSTALLATION .....	3-4
MULTIBUS CARD REMOVAL .....	3-4
MULTIBUS CARD CONFIGURATIONS .....	3-5
Color Graphics Controller .....	3-5
Intelligent Serial Interface Card .....	3-6
Disk Server Card .....	3-7
SASI Disk Bus Interface Adapter .....	3-8
Local Memory Card .....	3-9
CPU Card .....	3-10
Clock Calendar Card .....	3-11
Global Memory Card - I.D. Number: PSM-2P .....	3-12
Global Memory Card - I.D. Number: INTEL SBC020EX .....	3-13
MODULE MOUNTING UNIT (MMU) .....	3-14
NETWORK 90 MODULES .....	3-16
Installation .....	3-16
Removal .....	3-16
Loop Interface Module .....	3-17
Bus Transfer Module .....	3-18
Loop Storage Module .....	3-19
AC DISTRIBUTION BOARD .....	3-20
CIRCUIT BREAKER (CB1) - 120 V AC .....	3-21
COLOR MONITOR .....	3-22
DIN BOARD .....	3-23
I/O DISTRIBUTION BOARD .....	3-24
DISK DRIVE CONTROLLER CARD .....	3-26
FLOPPY DISK DRIVE - TEAC .....	3-27
FLOPPY DISK DRIVE - NEC .....	3-29
HARD DISK DRIVE CYNTHIA (BULL) 55 MBYTE .....	3-30
HARD DISK DRIVE VERTEX (PRIAM) V150/V185 .....	3-31
HARD DISK DRIVE PRIAM V185A 85 MBYTE .....	3-32

## Table of Contents (Continued)

	Page
<b>SECTION 3 - STANDARD HARDWARE (Continued)</b>	
MCS KEYBOARD INTERFACE CARD (MKI) . . . . .	3-33
MCS ENHANCED KEYBOARD INTERFACE CARD (EMKI) . . . . .	3-34
CONVENIENCE OUTLETS . . . . .	3-35
POWER STATUS LIGHT AND ESD GROUND CONNECTION . . . . .	3-36
Power Status Light . . . . .	3-36
ESD Ground Connection . . . . .	3-36
POWER SUPPLY - I/O . . . . .	3-37
POWER SUPPLY - MAIN . . . . .	3-39
RESET BUTTON and CONTROLLER BOARD . . . . .	3-42
TERMINATION UNIT - COMMUNICATION LOOP . . . . .	3-43
<b>SECTION 4 - MCS OPTIONS . . . . .</b>	<b>4-1</b>
ANNUNCIATOR/DISPLAY SELECT BOARD (ADS) . . . . .	4-2
APPLICATION PROCESSOR (AP) . . . . .	4-3
COLOR GRAPHICS CARD(S) . . . . .	4-5
COLOR MONITOR(S) . . . . .	4-6
COLOR VIDEO COPIER SYSTEM . . . . .	4-7
Operation Summary . . . . .	4-7
Installation . . . . .	4-8
ENGINEERING KEYBOARD(S) . . . . .	4-10
NINE TRACK REEL-TO-REEL TAPE TRANSPORT . . . . .	4-11
Unpacking . . . . .	4-11
Preparation, Transport, M990 . . . . .	4-13
Preparation, SCSI Interface Unit, CSC-100 . . . . .	4-13
External Setup . . . . .	4-14
System Interconnections . . . . .	4-15
Disk Server Upgrade . . . . .	4-16
PRINTER . . . . .	4-17
REDUNDANCY TRANSFER SWITCH . . . . .	4-18
Description . . . . .	4-18
Operation . . . . .	4-19
Top Circuit board . . . . .	4-20
External Switch . . . . .	4-21
Bottom Circuit Board . . . . .	4-22
System Configuration . . . . .	4-23
Mounting . . . . .	4-23
REMOTE ELECTRONICS DRIVER CABINET (MED) . . . . .	4-24
Field Test Panel . . . . .	4-25
Power Entry Panel (PEP) . . . . .	4-26
SCSI NINE TRACK REEL-TO-REEL TAPE TRANSPORT ADAPTER . . . . .	4-27
STREAMING TAPE DRIVE . . . . .	4-28
Backup and Restore Operation . . . . .	4-29
SUPERLOOP COMPUTER INTERFACE UNIT . . . . .	4-30
Loop Interface Slave . . . . .	4-31
Superloop Storage Module . . . . .	4-32

---

---

## Table of Contents (Continued)

	Page
<b>SECTION 4 - MCS OPTIONS (Continued)</b>	
TOUCH SCREEN . . . . .	4-33
Touch Screen Installation . . . . .	4-33
Touch Screen Controller Card Installation . . . . .	4-33
Calibration . . . . .	4-34
Calibration - Touch Screen Controller I.D. Number E271-60MKII (1947027_2) . . . . .	4-35
Calibration - Touch Screen Controller I.D. Number E271-60 (1947027_1) . . . . .	4-36
TRACKBALL . . . . .	4-37
Trackball Installation . . . . .	4-37
<b>SECTION 5 - MAINTENANCE . . . . .</b>	<b>5-1</b>
<b>PREVENTIVE MAINTENANCE . . . . .</b>	<b>5-1</b>
<b>TROUBLESHOOTING . . . . .</b>	<b>5-2</b>
Troubleshooting Guide . . . . .	5-2
Power-Up Tests . . . . .	5-4
AC Power . . . . .	5-4
DC Power . . . . .	5-4
Multibus Card and Subassembly Tests . . . . .	5-7
<b>DIAGNOSTICS IN EPROM . . . . .</b>	<b>5-12</b>
Command Syntax . . . . .	5-13
Mode . . . . .	5-13
CPU1, CPU2, DSV . . . . .	5-13
Diagnostic Commands . . . . .	5-14
File System Error Codes . . . . .	5-19
Disk Controller Error Codes . . . . .	5-21
UNIX I/O Error Codes . . . . .	5-22
Tape File Error Codes . . . . .	5-23
CIU Error Codes . . . . .	5-24
<b>PART REPLACEMENT PROCEDURES . . . . .</b>	<b>5-26</b>
Card Cage . . . . .	5-26
Color Monitor . . . . .	5-26
Disk Drive Controller Card . . . . .	5-26
Fan Assembly . . . . .	5-26
Floppy Disk Drive . . . . .	5-26
Hard Disk Drive . . . . .	5-27
MCS Keyboard . . . . .	5-27
I/O Power Supply . . . . .	5-27
Main Power Supply . . . . .	5-27
Reset Assembly . . . . .	5-28
Termination Unit . . . . .	5-28
<b>SECTION 6 - SERVICE AND NEW PARTS . . . . .</b>	<b>6-1</b>
<b>REPLACEMENT PARTS AND ORDERING INSTRUCTIONS . . . . .</b>	<b>6-1</b>
<b>TRAINING . . . . .</b>	<b>6-1</b>
<b>TECHNICAL DOCUMENTATION . . . . .</b>	<b>6-1</b>
<b>APPENDIX A - WIRE AND COMPONENT LOCATION . . . . .</b>	<b>A-1</b>

## List of Figures

No.	Title	Page
1-1.	Management Command System - NMCS02	1-1
1-2.	Front and Rear Views of NMCS02	1-4
2-1.	NMCS02 NTCL01 and AC Distribution Board Location	2-2
2-2.	NMED01 PEP and NICL01 Location	2-3
3-1.	MCS Multibus Card Cage (Front View)	3-2
3-2.	Multibus Card Cage (Back View)	3-3
3-3.	Inserting MCS Card Into Multibus Card Cage	3-4
3-4.	Color Graphics Controller Card	3-5
3-5.	Intelligent Serial Interface Card	3-6
3-6.	Disk Server Card	3-7
3-7.	SASI Disk Bus Interface Adapter	3-8
3-8.	Local Memory Card	3-9
3-9.	CPU Cards 1 and 2	3-10
3-10.	Clock Calendar Card	3-11
3-11.	2 MEG RAM Memory Card (ID Number PSM-2P)	3-12
3-12.	2 MEG RAM Memory Card (I.D. Number INTEL SBC020EX)	3-13
3-13.	Module Mounting Unit - Front View	3-14
3-14.	Module Mounting Unit - Back View Wiring Connections	3-14
3-15.	Loop Interface Module Configuration	3-17
3-16.	Bus Transfer Module Configuration	3-18
3-17.	Loop Storage Module - NLSM02 (Bottom Board)	3-19
3-18.	Location of AC Distribution Board	3-20
3-19.	Location of 120 V AC Main Circuit Breaker (Rear View)	3-21
3-20.	Location of Color Monitor	3-22
3-21.	Location of DIN Board	3-23
3-22.	Location of I/O Distribution Board	3-24
3-23.	Disk Drive Controller Card	3-26
3-24.	TEAC Floppy Disk Drives	3-27
3-25.	TEAC Floppy Disk Drive	3-28
3-26.	NEC Floppy Disk Drives	3-29
3-27.	CYNTHIA (BULL) 55 Megabytes Hard Disk	3-30
3-28.	VERTEX (PRIAM) Hard Disk Drive	3-31
3-29.	PRIAM V185A Hard Disk Drive	3-32
3-30.	Location of Keyboard Controller Card - Main Console	3-33
3-31.	EMKI Keyboard Electronics Controller Card	3-34
3-32.	Location of Convenience Outlets J7 and J8	3-35
3-33.	Location of Power Status Light and ESD Ground Connection	3-36
3-34.	Location of I/O Power Supply	3-37
3-35.	I/O Power Supply (Top View)	3-38
3-36.	Location of Main Power Supply	3-39
3-37.	Main Power Supply (Top View)	3-41
3-38.	Location of Reset Button and Controller Board	3-42
3-39.	NTCL01 Communication Loop Termination Unit	3-43
4-1.	Location of Annunciator/Display Select Board	4-2
4-2.	Application Processor	4-3
4-3.	Location and Configuration of Color Graphics Controller Cards	4-5



## List of Figures (Continued)

No.	Title	Page
4-4.	Back View of the Color Video Processor . . . . .	4-8
4-5.	Engineering Keyboard Connector . . . . .	4-10
4-6.	Reel-to-Reel Tape Drive Unit . . . . .	4-12
4-7.	Transport Tape Mechanism . . . . .	4-12
4-8.	LED and Switch Location . . . . .	4-14
4-9.	Loading Tape . . . . .	4-16
4-10.	MCS Hardware Configuration Using the NMRT01 . . . . .	4-18
4-11.	NMRT01 Top Circuit Board . . . . .	4-19
4-12.	NMRT01 External Switch . . . . .	4-21
4-13.	NMRT01 Bottom Circuit Board . . . . .	4-22
4-14.	MRT Mounting . . . . .	4-23
4-15.	Front and Rear Views of the NMED01 . . . . .	4-24
4-16.	Field Test Panel . . . . .	4-25
4-17.	Power Entry Panel (PEP) . . . . .	4-26
4-18.	SCSI Adapter Card . . . . .	4-27
4-19.	NSTP01 Cable Connections . . . . .	4-28
4-20.	Tape Drive and Internal Controller Card Jumper Settings . . . . .	4-29
4-21.	Loop Interface Slave - NLIS01 . . . . .	4-31
4-22.	Superloop Storage Module - NSSM01 . . . . .	4-32
4-23.	Manual Touch Screen Calibration . . . . .	4-34
4-24.	Touch Screen Controller Card - I.D. Number E271-60MKII . . . . .	4-35
4-25.	Touch Screen Controller Card - I.D. Number E271-60 . . . . .	4-36
4-26.	Trackball Location . . . . .	4-37
5-1.	Apply Power to the MCS with the Main Circuit Breaker (CB1) . . . . .	5-4
5-2.	Wiring Schematic for Main Power Supply . . . . .	5-5
A-1.	Membrane Keyboard . . . . .	A-2
A-2.	NMCS02 Rear CRT Enclosure . . . . .	A-2
A-3.	NMCS02 Power Supplies . . . . .	A-3
A-4.	NMCS02 I/O and AC Distribution Board . . . . .	A-3
A-5.	Color Graphics Card . . . . .	A-4
A-6.	Intelligent Serial Interface Card . . . . .	A-4
A-7.	Local Memory Card . . . . .	A-5
A-8.	M68CPU Card used for CPU #2, Application Processor, Disk Server (w/o SASI and SCSI Cards), and CPU #1 (w/o Clock Card) . . . . .	A-5
A-9.	Disk Server Card . . . . .	A-6
A-10.	CPU #1 Card . . . . .	A-6
A-11.	Touch Screen Controller Card - I.D. Number E271-60MKII . . . . .	A-7
A-12.	Touch Screen Controller Card - I.D. Number E271-60 . . . . .	A-7
A-13.	SCSI Card . . . . .	A-8
A-14.	SASI Card . . . . .	A-8
A-15.	Clock Calendar Card . . . . .	A-8
A-16.	TEAC FD-55GF-60-U Floppy Drive . . . . .	A-9
A-17.	TEAC FD-55GFR-541-U Floppy Drive . . . . .	A-10
A-18.	NEC FD1157C Floppy Drive . . . . .	A-11
A-19.	Multibus Backplane . . . . .	A-12
A-20.	Hard Disk Controller Card . . . . .	A-12

## List of Tables

No.	Title	Page
1-1.	Hardware Description . . . . .	
3-1.	Multibus Card Cage Assignments . . . . .	1-3
3-2.	Card Priority Jumper Settings . . . . .	3-1
3-3.	MCS Multibus Wiring Connections . . . . .	3-3
3-4.	Serial Port Function . . . . .	3-3
3-5.	Wiring Connections to MMU Backplane Tabs . . . . .	3-6
3-6.	Wiring Connections For AC Distribution Board . . . . .	3-15
3-7.	Wiring Connections to 120 V AC Main Circuit Breaker . . . . .	3-20
3-8.	Connections to Color Monitor . . . . .	3-21
3-9.	Connections to DIN Board . . . . .	3-22
3-10.	I/O Distribution Board Assignments . . . . .	3-23
3-11.	Connections to Disk Drive Controller Card . . . . .	3-25
3-12.	Connections for Main Keyboard Controller Card . . . . .	3-26
3-13.	Connections for EMKI Controller Card . . . . .	3-33
3-14.	Connections to Convenience Outlets J7 and J8 . . . . .	3-34
3-15.	Connections to Power Status Light . . . . .	3-35
3-16.	Connections to I/O Power Supply . . . . .	3-36
3-17.	Connections on TB1 of Main Power Supply . . . . .	3-37
3-18.	Connections on rear of Main Power Supply . . . . .	3-39
4-1.	Connections to Annunciator/Display Select Board . . . . .	3-40
4-2.	Transforming MCS CPU Card into an AP Card . . . . .	4-2
4-3.	Color Monitor Options . . . . .	4-4
4-4.	NMRT01 Power Supply Jumper Settings . . . . .	4-6
4-5.	Wiring Connection to Field Test Panel . . . . .	4-22
4-6.	Wiring Connections to the PEP . . . . .	4-25
5-1.	Graphics Controller Card Self-Test Status . . . . .	4-26
5-2.	Disk Read Test Error Codes . . . . .	5-9
5-3.	Control Commands for Advanced Diagnostics . . . . .	5-11
6-1.	MCS Recommended Spare Parts List . . . . .	5-12
6-2.	NMED01 Recommended Spare Parts . . . . .	6-4
6-3.	Touch Screen Recommended Spare Parts . . . . .	6-4

---

---

## List of Effective Pages

Total number of pages in this manual is 146, consisting of the following:

Page No.	Change No.
Preface	Original
iii through xii	Original
1-1 through 1- 6	Original
2-1 through 2- 4	Original
3-1 through 3-44	Original
4-1 through 4-38	Original
5-1 through 5-28	Original
6-1 through 6- 2	Original
A-1 through A-12	Original

When an update is received, insert the latest changed pages and dispose of superseded pages.

**NOTE:** On an update page, the changed text or table is indicated by a vertical bar in the outer margin of the page adjacent to the changed area. A changed figure is indicated by a vertical bar in the outer margin next to the figure caption. The date the update was prepared will appear under the page number.

## Safety Summary

### General Warnings Static Shock

#### Electrical Shock Hazard During Maintenance

Disconnect power or take precautions to insure that contact with energized parts is avoided when servicing.

#### Special Handling

The MCS uses Electrostatic Sensitive Devices (ESD). ESD protection during handling is required.

### Avertissement D'Ordre General Static Le Zappa

#### Risques de chocs electriques lors de l'entretien

S'assurer de debrancher l'alimentation ou de prendre les precautions necessaires a eviter tout contact avec des composantes sous tension lors de l'entretien.

#### Precautions de Manutention

Le MCS contient des composantes sensibles aux decharges electrostatiques.

### Specific Warnings

Do not operate the MCS with doors or covers opened or removed. Figure 2 is only for illustrative purposes. (p. 1-4 )

Flip main circuit breaker to Off, before attempting to remove any cards. (p. 3-4)

Disconnect from electrical supply before attempting repair or replacement. (p. 5-27 )

### Avertissement D'Ordre Specifique

Ne pas faire fonctionner le MCS lorsque les portes ou les panneaux d'accès sont ouverts ou enlevés. Le MCS n'est représenté à la figure 2 qu'à titre d'illustration seulement. (p. 1-4)

Debrancher de la source electrique avant de proceder a des travaux de reparation ou de remplacement. (p. 5-27 )

---

---

## SECTION 1 – INTRODUCTION

### GENERAL INTRODUCTION

The Management Command System (MCS) is an operator console that provides integrated operations and data acquisition capabilities for plantwide control. It is a flexible, state-of-the-art system that features 10,000 tag capacity, distribute trending, high resolution CRT displays with optional touch screens, and archival storage.

### SECTION CONTENT

This document is organized in the following manner:

**Section 1 - Introduction** describes the physical attributes of the MCS, associated hardware, and provides a complete list of system specifications.

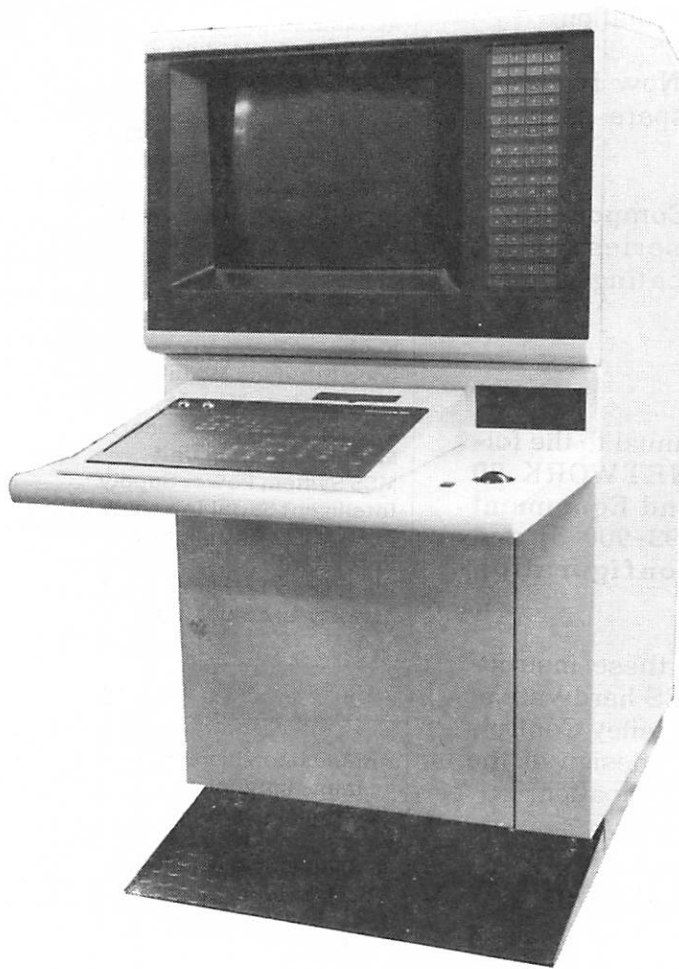

*Figure 1-1. Management Command System - NMCS02*

**Section 2 - Installation and Start-Up** gives complete instruction on installation procedures.

**Section 3 - Standard Hardware** gives the standard hardware configurations for a base MCS as provided by Bailey Controls Co. at the time of this printing. Some of the hardware described in this section may not be provided on existing systems.

**Section 4 - MCS Options** describes the available MCS options and configuration and installation procedures for these options.

**Section 5 - Maintenance** describes preventive maintenance necessary and includes troubleshooting information.

**Section 6 - Service and New Parts** includes a recommended spare parts list.

**Appendix A - Wire and Component Location** provides a series of photographs to aid in locating and replacing MCS components.

## RELATED DOCUMENTS

References are made in this manual to the following Bailey publications: **NETWORK 90 Site Planning, Preparation, and Equipment Installation Instructions (IE93-900-5)** and the **MCS Operation and Configuration Manual (IE93-901-21)**.

The information contained in these instructions accurately reflects the MCS hardware at the time of printing. However, Bailey Controls reserves the right to revise the design of the MCS hardware without prior notification.

## MANAGEMENT COMMAND SYSTEM (NMCS02) - PHYSICAL DESCRIPTION

The NMCS02 dimensions are approximately 53 inches high by 28 inches wide by 46 inches deep. It has front and rear swing-out doors with individual locks. The rear door and the keyboard counter have slotted sections to

accommodate the air intake and exhausts of the unit's internal cooling system. The unit is provided with a stabilizer which must be fastened to the front when the NMCS02 is not secured to the floor. One 2.5 inch diameter cable entry is provided at the bottom right rear of the unit.

## STANDARD MCS HARDWARE

The standard model of the Management Command System is the stand-up console; the NMCS02. The following lists contain the hardware included in the standard MCS and available options. Additional information is found in Table 1-1.

STANDARD HARDWARE
AC Distribution Board
Bus Transfer Module
Color Graphics Controller Card
Color Monitor
Two Pair of CPU/Memory Cards (with Serial Interface and Clock Calendar Cards)
DIN Connector
Input/Output (I/O) Power Supply
I/O Distribution Panel
Fan Assembly
Floppy Disk Drive
Hard Disk Drive
Keyboard Electronics
Loop Interface Module
Loop Storage Module
2 Megabytes RAM Memory Cards
Module Mounting Unit
MCS System Power Supply
Intelligent Serial Interface Card
Disk Drive Controller Card
Reset Card
Plant Loop Termination Unit
Twenty-six Slot Multibus Card Cage

OPTIONS
Annunciator/Display Select Panel - 64 key mini-annunciator panel
Additional Color Graphics Cards, Monitors, and Keyboards
Redundancy Transfer Switch
Touch Screen
Trackball
QWERTY style auxiliary keyboard
Standard black/white printer
High speed black white printer
Color video copier
9-Track Magnetic tape for archival storage
Applications Processor
Streaming Tape

*Table 1-1. Hardware Description*

Nomenclature	Description
NCRT01	Tabletop 19" CRT with keyboard
NCRT02	19" CRT console with keyboard
NCRT03	Standup environmental unit; 19" CRT with keyboard
NCRT04	Two 19" CRTs with one keyboard
NCRT05	Tabletop 19" CRT without keyboard
NCRT06	Panel mount 19" CRT (optional keyboard)
NCRT09	19" CRT only in a NCRT02 style cabinet; no keyboard
NMCS02	<p>Integrated Unit consisting of:</p> <p><b>Console Cabinet:</b></p> <p>19" color CRT (640 x 480 pixel resolution)</p> <p>Membrane Operator Keyboard; functional layout, 32 user-assignable keys</p> <p><b>Electronics:</b></p> <p>Superloop/Plant Loop Interface</p> <p>85 Megabyte Hard Disk Drive</p> <p>1.2 Megabyte Floppy Disk Drive; 5-1/4" format</p> <p>Annunciator Relays and Audible Tones</p> <p>Multiple 68000 family microprocessor board sets</p> <p>RAM memory</p> <p>Battery-backed Real Time Clock</p> <p>Serial I/O ports</p>
NMED01	Remote Electronics Driver Cabinet Same electronics as NMCS02 in standard full height NCAB06 cabinet.
<p>Note: All slaves can be used with NMCS02 or NMED01.</p>	

## NMCS02 - COMPONENT LOCATION

Figure 1-2 illustrates the front and rear views of the NMCS02 with its doors removed. This figure shows the physical relationship between the sub-assemblies internal to this unit.

### WARNING

Do not operate the MCS with doors or covers opened or removed. Figure 1-2 is only for illustrative purposes.

### AVERTISSEMENT

Ne pas faire fonctionner le MCS lorsque les portes ou les panneaux d'accès sont ouverts ou enlevés. Le MCS n'est représenté à la figure 1-2 qu'à titre d'illustration seulement.

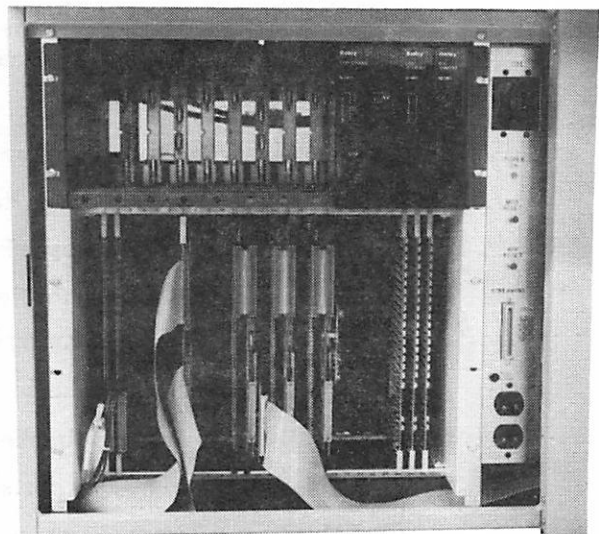
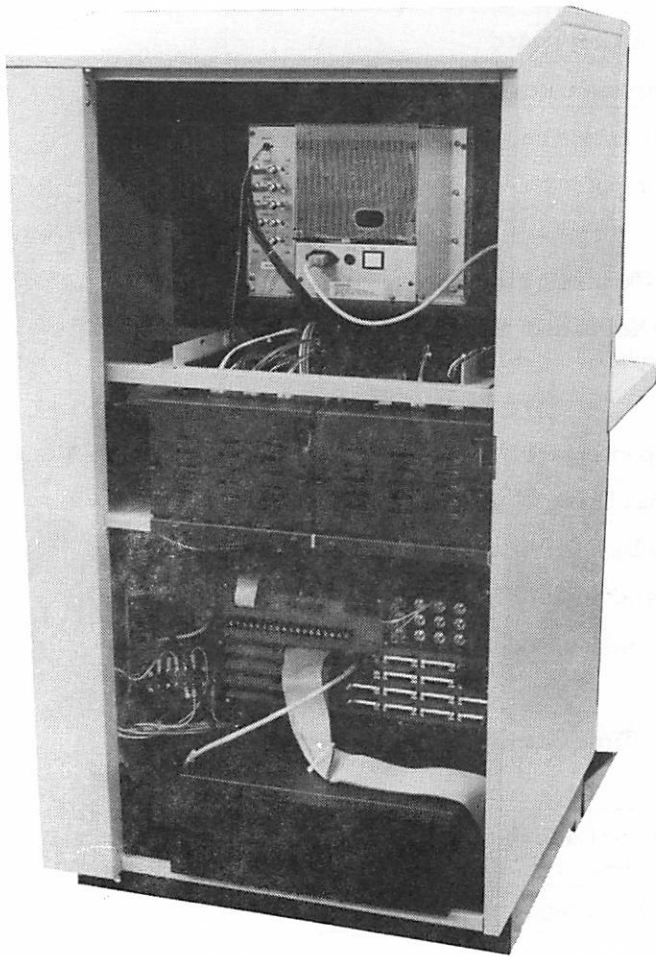

Figure 1-2. Front and Rear Views of NMCS02



**SPECIFICATIONS - NMCS02**

<b>Line Voltage</b>	103 to 132 V rms
<b>Line Frequency</b>	47 to 63 Hz
<b>Current</b>	
Inrush (half-cycle)	63.2 amps
Nominal (120 V ac line)	19.25 amps
<b>Power Factor</b>	0.65
<b>Crest Factor</b>	2.19
<b>Power Consumption</b>	2,200 watts
<b>Environmental Constraints</b>	
<b>Temperature</b>	
Operating	4° to 40°C (40° to 104°F)
Storage	-22° to 60°C (-8° to 140°F)
Transportation	-30° to 60°C (-22° to 140°F)
<b>Relative Humidity</b>	
Operating	20% to 80% non-condensing
Storage	10% to 90% non-condensing
Transportation	5% to 95% non-condensing
<b>Altitude</b>	-1,000 feet to +10,000 feet
<b>Cooling Requirements</b>	7,500 BTU/hr. maximum
<b>Weight</b>	453 lbs (305.5 kg)
<b>CRT Resolution</b>	640 x 480 pixels
<b>Touch Screen Resolution</b>	4,096 x 4,096 points
<b>Configuration</b>	Non-volatile ROM and hard disk memory
<b>Display Screens</b>	1,000; 200 dynamic items per screen
<b>Control/Display Selects</b>	200 selects from touch screen 200 selects from keyboard
<b>Tags</b>	10,000 standard
<b>Trends</b>	1,000
<b>Logs</b>	100 in any combination of Trend, Trip and Periodic Logs; Sequence of Events logs are additional.
<b>Certification</b>	CSA certification for use in an ordinary (non-hazardous) location pending.

Specifications Subject To Change Without Notice



---

---

## SECTION 2 – INSTALLATION AND START-UP

### UNPACKING AND VISUAL INSPECTION

Upon receipt of the MCS, examine the shipping crate for damage. Any damage should be reported immediately to the carrier. If immediate repair or replacement is necessary, notify your nearest Bailey sales/service office.

If the MCS is not put into prompt service, it should be left in its original shipping package.

If the MCS is to be placed into storage, maintain the storage environment specified in Section 1 of this manual. If the storage period is over a week in duration, disconnect the clock battery by removing a jumper (refer to Clock Calendar Card in Section 3). Failure to do so will result in excessive battery drain, requiring replacement of the Clock Calendar card.

### MCS INSTALLATION

Refer to the Bailey Controls manual, *Site Planning, Preparation and Equipment Installation (E93-900-5)*, for site selection, preparation, and hardware installation of the NETWORK 90 control system including the MCS. This document includes requirements and/or recommendations for load bearing of floors, space around equipment, temperature, humidity, shock and vibration, AC power wiring, AC power and DC signal common grounding, line conditioning, uninterruptable power supplies, radio frequency and electromagnetic interference, electrostatic discharge, lighting, equipment protection, equipment handling, and storage.

The following information gives the user all the steps required to install and power up the MCS.

1. Open the back door of the MCS or MED cabinet. This provides access to the terminals needed for wiring to your Plant Loop or Super-loop System and AC power.

2. Connect the Plant Loop or Super Loop Communication Link. (Refer to Section 3 of

this manual, *TERMINATION UNIT - COMMUNICATION LOOP*, for further information.)

#### NMCS02:

Located at the rear of the NMCS02 to the lower left is a rack which accommodates a Communication Link Termination Unit (NTCL01) (Figure 2-1). Refer to the NTCL01 in the Bailey Termination manual E93-911 for wire connections.

#### NMED01:

Located at the rear of the NMED01 above the Multibus Card cage is a rack which accommodates a Communication Link Termination Module (NICL01) (Figure 2-2). Refer to the NICL01 in the Bailey Termination manual E93-911 for wire connections.

3. The next step is to wire AC power to the MCS or MED.

The recommended minimum size for power wiring to the MCS is 14 AWG copper wire with a 600 V, 75° C rating and thermoplastic insulation. Wire with a 300 V or 150 V rating may be used provided it is: accepted by local wiring codes, protected by cable trays or conduit and suited for the service voltage.

The power wiring to the MCS must include a third-wire grounding conductor. This grounding conductor must not be of a smaller gauge than the power wiring and must be either bare or green colored, if insulated. The grounding conductor must be terminated at the system safety ground connection.

The over-current protection provided for your AC distribution must be sized to allow for the inrush current required by the MCS hardware. See Section 1 for the peak inrush current and duration for the MCS.

For other power wiring and grounding considerations, such as line conditioning, and

EMI (electromagnetic interference), refer to manual E93-900-5, Site Planning, Preparation and Equipment Installation.

**3a. NMCS02:**

Located just below the Communication Link Termination Unit, the AC Distribution Board (Figure 2-1) accepts 120 V ac at 50/60 Hz. Connect one side of the 120 V ac line to TB2-L, and the other side to TB2-N. Connect the ground wire to TB2-G. (Refer to AC DISTRIBUTION BOARD in Section 3

of this manual for further information.) If other power is present at your plant, a compensating transformer is required.

**NOTE:** If remote CRTs are being installed, ensure they are powered using the same polarized power and ground as the MCS to prevent ground loops. Failure to do so may cause display distortion. If ground loops are still suspected, use of optically isolated modems will eliminate the problem.

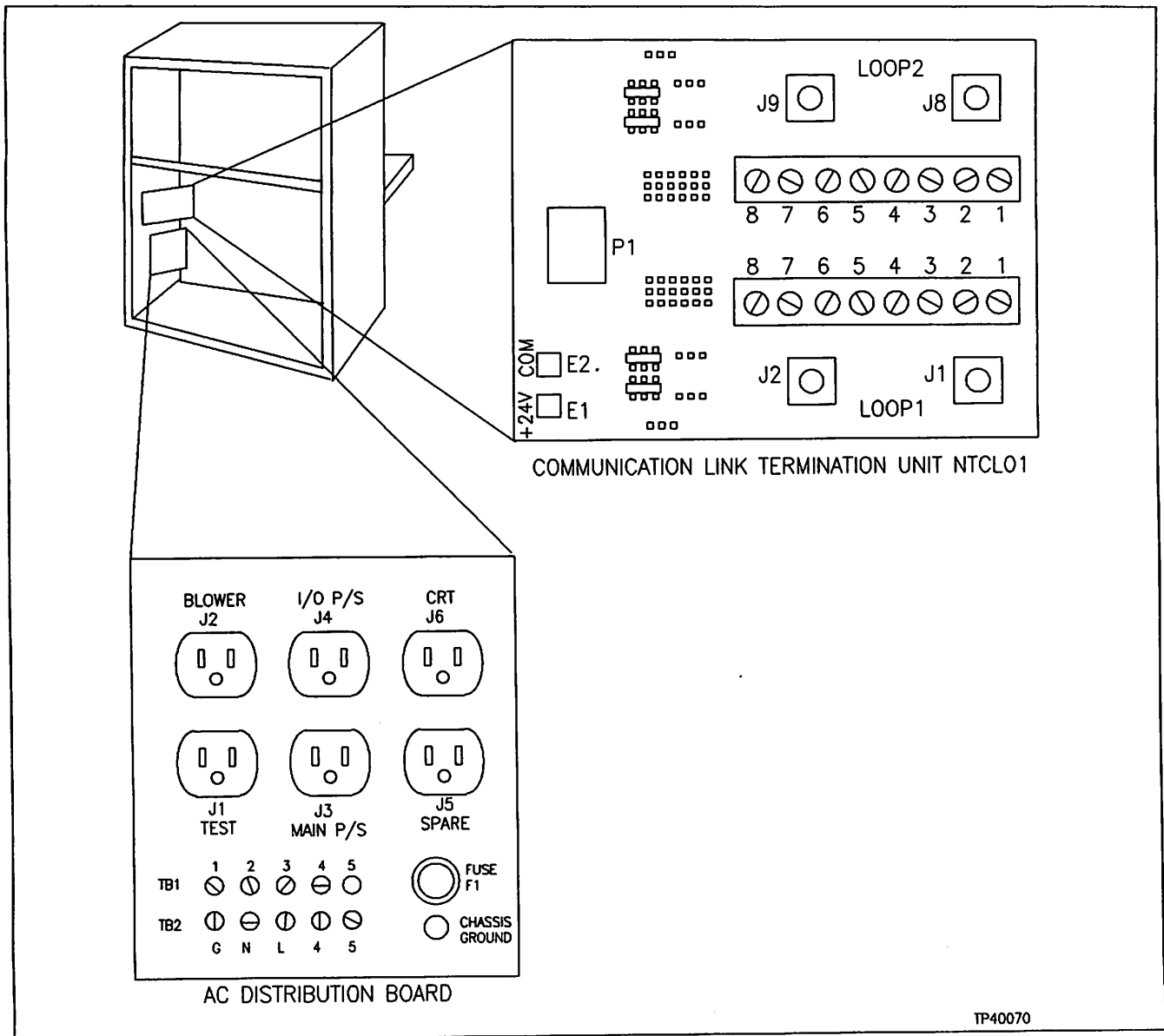

Figure 2-1. NMCS02 NTCL01 and AC Distribution Board Location

**3b. NMED01:**

Located just below the Power Supply near the top of the cabinet is the Power Entry Panel (PEP). The PEP accepts 120 V ac or 240 V ac at 50/60 Hz. A switch located on top of the power supply (Figure 2-2) is used to select the desired input voltage. Refer to **MCS REMOTE ELECTRONICS DRIVER CABINET, Power Entry Panel** in Section 4 of this manual for

wire connections. If other power is present at your plant, a compensating transformer is required.

**NOTE:** If remote CRTs are being installed, ensure they are powered using the same polarized power and ground as the MCS to prevent ground loops. Failure to do so may cause display distortion. If ground loops are still suspected, use of optically isolated modems will eliminate the problem.

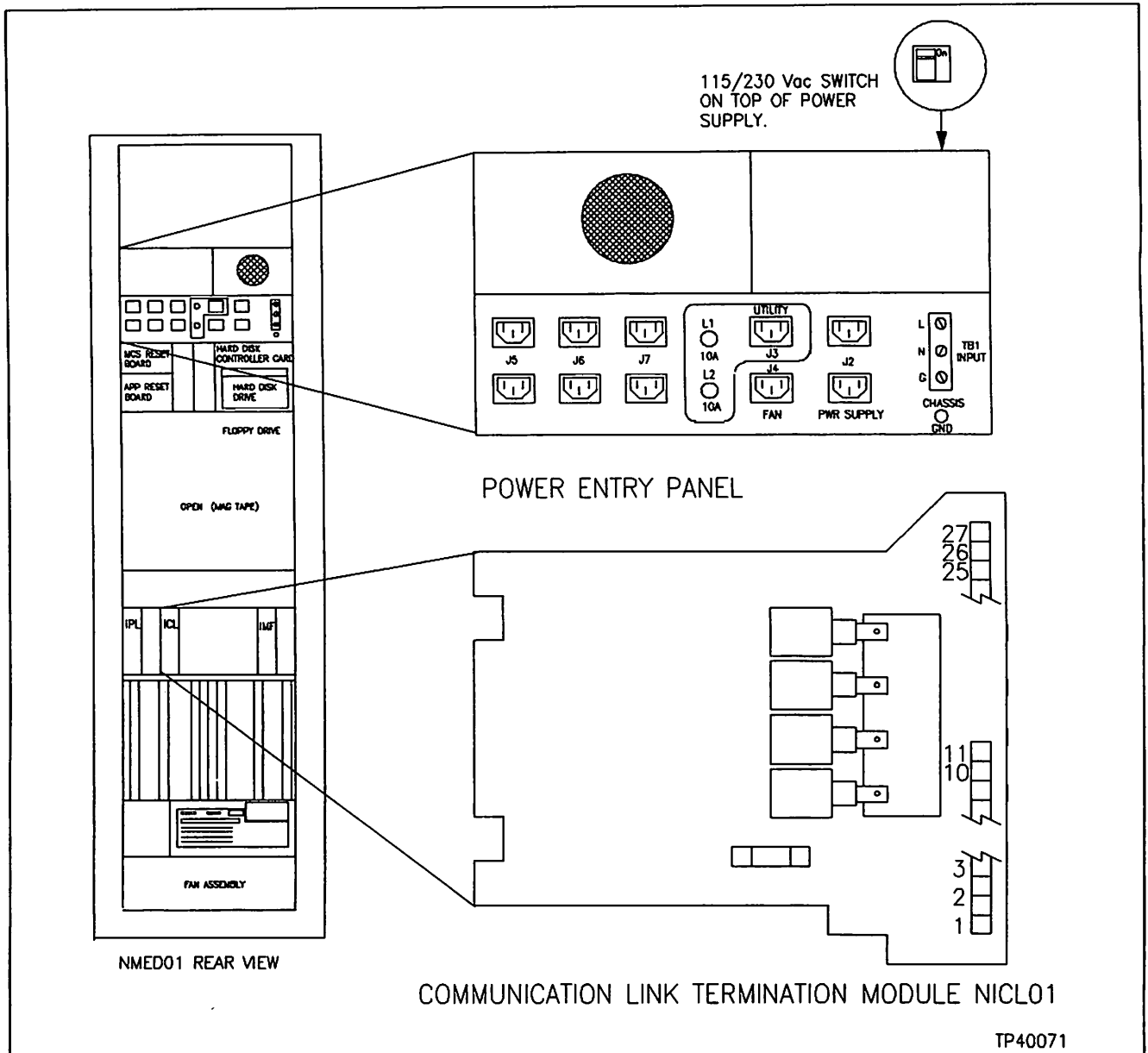

*Figure 2-2. NMED01 PEP and NICL01 Location*

---

4. During shipping, some problems may occur. Before applying power to the MCS, perform the AC and DC power-up tests in Section 5 of this manual. Adjust the supplies as shown, if necessary.

5. Once the wiring is complete, and the DC voltage sources have been checked, you are ready to apply power to the MCS. If problems

occur, refer to the Troubleshooting Chart in Section 5 of this manual.

MCS peripherals (keyboards, monitors, printers, etc.) are connected to the I/O Distribution Board. Refer to **I/O DISTRIBUTION BOARD** in Section 3 of this manual for wiring connections. If connecting an MCS touch screen, refer to **TOUCH SCREEN** in Section 4 of this manual.

## SECTION 3 – STANDARD HARDWARE

The following section is organized into three parts: multibus cards, NETWORK 90 modules, and other hardware components. Each section contains jumper and switch configurations for a standard MCS. The components in the MCS are factory configured. The configuration process described in Section 3 and Section 4 is not required to operate

your MCS. This information is given in case settings are inadvertently changed or hardware needs to be replaced. The general location of each component along with wire and cable connections are also given. This is only a reference section of standard equipment; information regarding other MCS options is given in Section 4 of this manual.

*Table 3-1. Multibus Card Cage Assignments*

Slot Number	Multibus Card	Bailey Part No. (P/N)
1	Color Graphics Controller 1	1948025_1
2	Color Graphics Controller 2 (optional)	1948025_1
3	Unused	-----
4	Color Graphics Controller 3 (optional)	1948025_1
5	Color Graphics Controller 4 (optional)	1948025_1
6	Unused	-----
7	Serial I/O Interface 1	1948021_1
8	Serial I/O Interface 2 (future)	1948021_1
9	Unused	
10	Unused	
11	Local Memory 3 (for Disk Server CPU)	6637447_1
12	Disk Server CPU	6637033_4
13	Disk Bus Adapter Interface (SASI)	1948023_1
14	Unused	-----
15	MCS CPU 2	6637033_3
16	Local Memory 2 (for MCS CPU 2)	6637447_1
17	Local Memory 1 (for MCS CPU 1)	6637447_1
18	MCS CPU 1	6637033_2
19	Clock Calendar	1947999_1
20	Unused	-----
21	Unused	-----
22	Local Memory 4 (optional) (for Applications Processor)	6637447_1
23	Applications Processor (NAPP02) (optional)	6637033_1
24	2 Megabytes of Global RAM Memory 1	6637446_7
25	2 Megabytes of Global RAM Memory 2	6637446_8
26	2 Megabytes of Global RAM Memory 3	6637446_9

# MULTIBUS CARD CAGE - FRONT VIEW

Bailey P/N - 1948017\_1

The Multibus card cage provides the communication paths and defines the priority level for the MCS Multibus cards. The MCS cards in the card cage are slot dependent. Card placement is shown in Figure 3-1.

NOTE: Figure 3-1 reflects the maximum amount of hardware available with the MCS. This may be more than is contained in your current system.

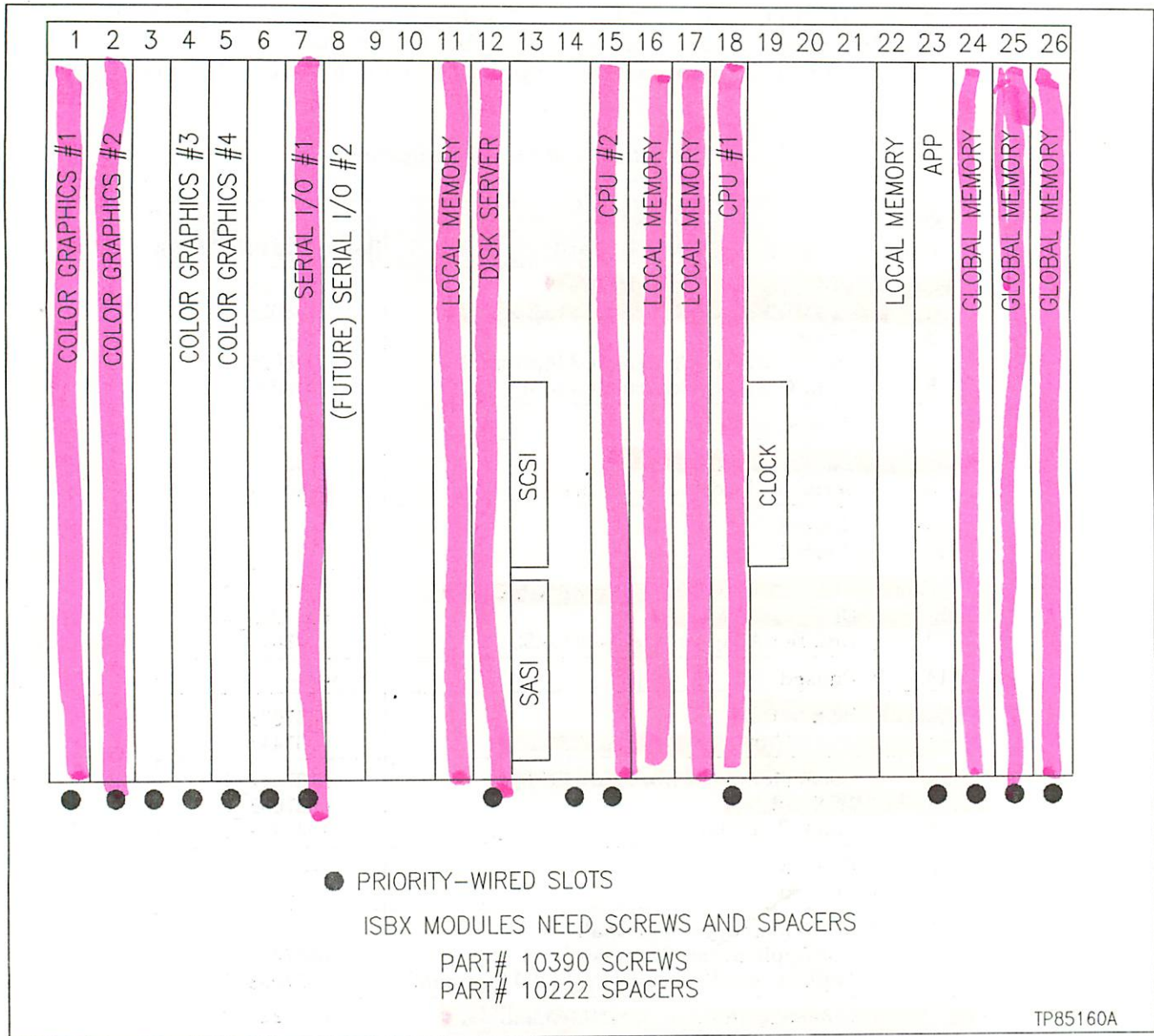

Figure 3-1. MCS Multibus Card Cage (Front View)



## MULTIBUS CARD CAGE - BACK VIEW

Bailey P/N - 1948017\_1

Each card in the MCS Multibus card cage has a required priority level. The priority level is determined by wire jumper settings J1 through J4 (Table 3-2) on the back of the card cage. The card cage back view (Figure 3-2) shows the location of the jumper pins and power terminals. Card cage power connections are listed in Table 3-3.

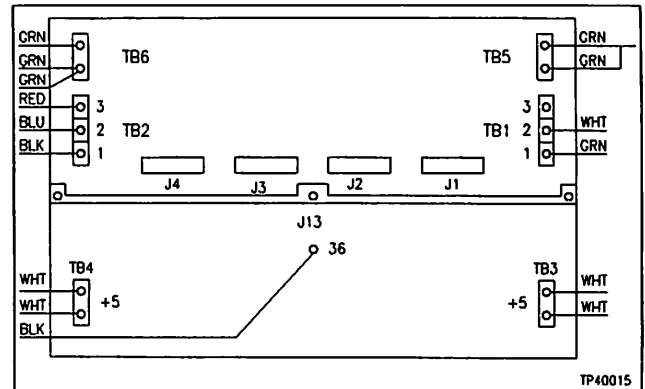

Figure 3-2. Multibus Card Cage (Back View)

Table 3-2. Card Priority Jumper Settings

Card Slot	J4	J3	J2	J1	Card Slot
(Highest Priority)					
14	1 - 14	14 - 1	1 - 14	14 - 1	1
15	2 - 15	15 - 2	2 - 15	15 - 2	2
16	3 N/C	N/C 3	3 - 16	16 - 3	3
17	4 N/C	N/C 4	4 - 17	17 - 4	4
18	5 - 16	16 - 5	5 - 18	18 - 5	5
19	6 N/C	N/C 6	6 - 19	19 - 6	6
20	7 - 17	17 - 7	7 - 20	20 - 7	7
21	8 N/C	N/C 8	8 N/C	N/C 8	8
22	9 N/C	N/C 9	9 N/C	N/C 9	9
23	10 - 18	18 - 10	10 N/C	N/C 10	10
24	11 - 19	19 - 11	11 N/C	N/C 11	11
25	12 - 20	20 - 12	12 - 21	21 - 12	12
26	13 - 21	21 - 13	13 N/C	N/C 13	13
(Lowest Priority)					

Table 3-3. MCS Multibus Wiring Connections

J13	TB1	TB2	TB3	TB4	TB5	TB6
Use wire assembly number 6636493_2* Connect:			Use wire assembly number 6636494_2 Connect:			
Black wire to position 36	Green wire to terminal one  White wire to terminal two  Make no connection to terminal three	Black wire to terminal one  Blue wire to terminal two  Red wire to terminal three	Two white wires from each tab position to CH1 POS on Power Supply	One white wire from each tab position to CH1 POS on Power Supply	One green wire from each tab position to CH1 NEG on Power Supply	Two green wires from each tab position to CH1 NEG on Power Supply  One green wire from assembly number 6636493_2
* This wire assembly plugs into the Multibus socket adjacent to the Power Supply.						

---

## MULTIBUS CARD INSTALLATION

The Multibus cards insert into the Card Cage along two guide rails. Slide the card into the desired position, being careful to align it beneath the slot number. Press on the card removal tabs (Figure 3-3) to fully insert the card into the multi-bus backplane.

## MULTIBUS CARD REMOVAL

### WARNING

Flip main circuit breaker to Off, before attempting to remove any cards.

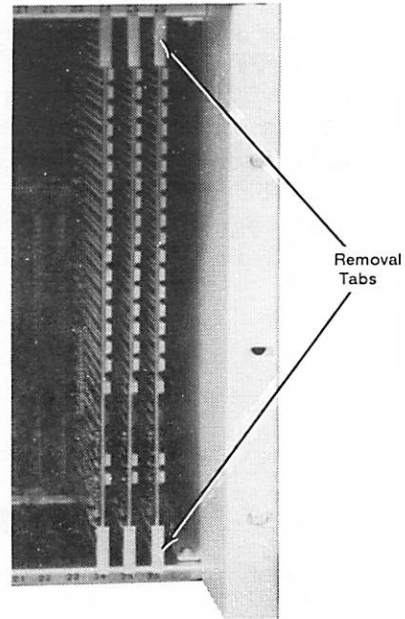

Figure 3-3. Inserting MCS Card Into Multibus Card Cage

Remove the cards by pulling the latches toward you and gently sliding the card out of the cage.

# MULTIBUS CARD CONFIGURATIONS

**Color Graphics Controller**  
Bailey P/N - 1948025\_1

The MCS Color Graphics Controller card drives the MCS monitor. The card address is set by wire-wrapping jumpers to the appropriate pins. The location of the pins is shown in Figure 3-4.

**NOTE:** Refer to Section 4, MCS Options, for the jumper settings of any additional color graphics cards.

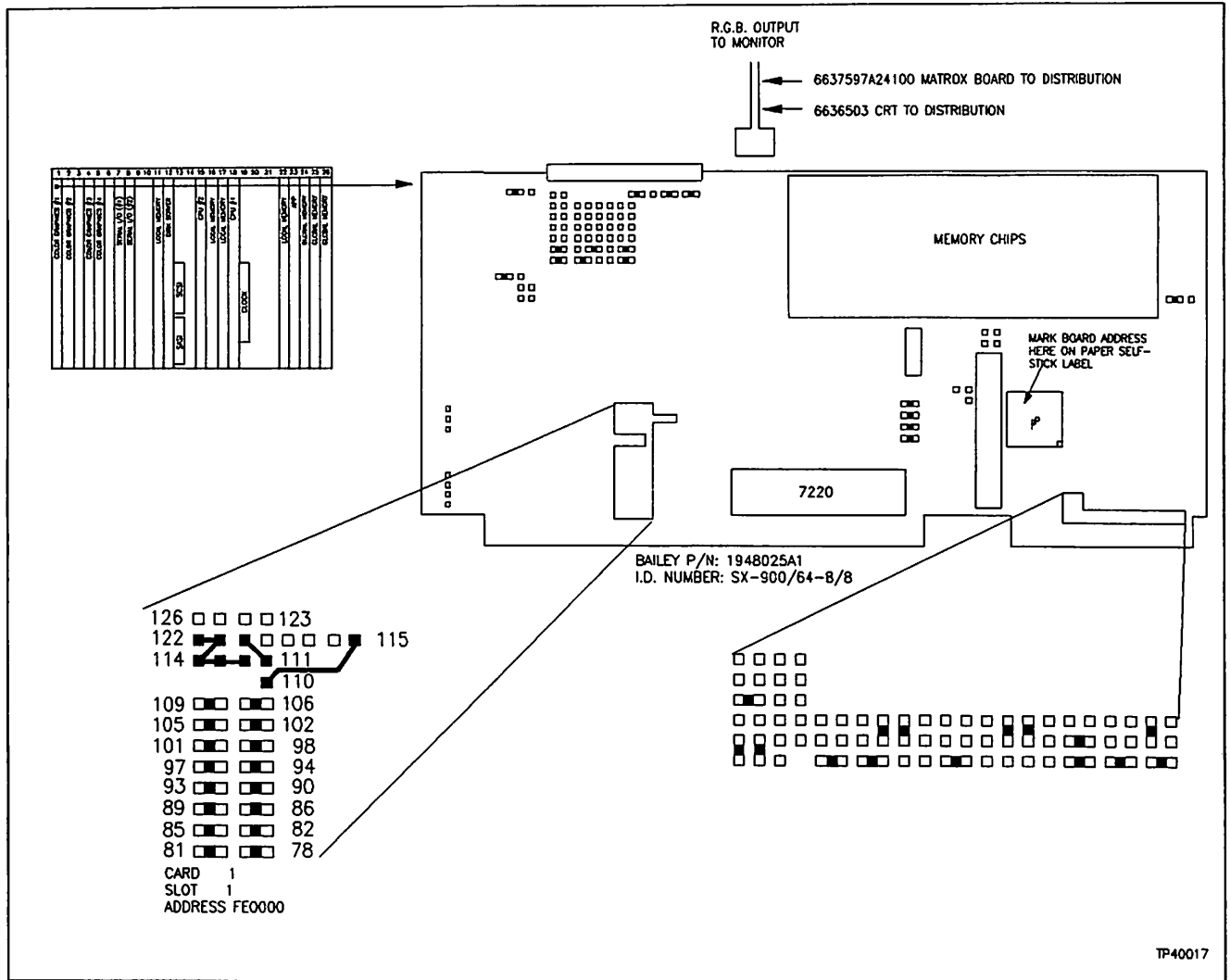

Figure 3-4. Color Graphics Controller Card

**Intelligent Serial Interface Card**  
Bailey P/N 1948021\_2

The MCS gains access to various peripherals through the Intelligent Serial Interface Card. The peripherals include keyboards, printers and terminals. This card is configured by setting jumpers and dipswitches (Figure 3-5). Refer to Table 3-4 for port assignments.

**NOTE:** Jumpers located below IC32 must be set according to the size of RAM used for IC32, 16K or 64K. The number 16 or 64 (located within the chip number) is printed on IC32. Set the jumper according to this number.

**MULTIBUS CARD CONFIGURATIONS**

*Table 3-4. Serial Port Function*

Port	Function
1	Keyboard 1
2	Keyboard 2
3	Keyboard 3
4	Aux/CIU
5	Printer 1
6	Keyboard 4
7	Printer 2
8	Diagnostic Terminal (DDT) I/O Port 0100 RAM Address FA0000 to FAFFFF 64K Block

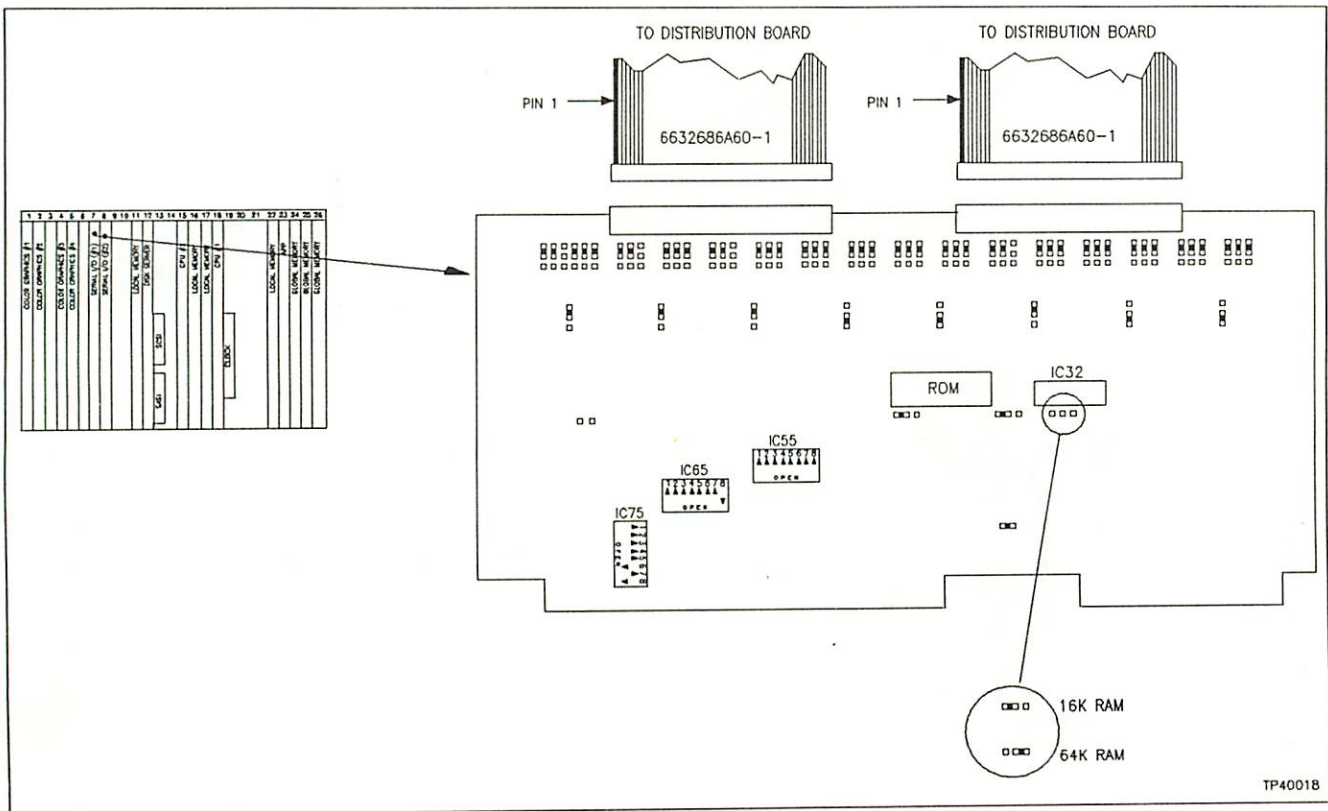

*Figure 3-5. Intelligent Serial Interface Card*

# MULTIBUS CARD CONFIGURATIONS

Disk Server Card  
Bailey P/N - 6637033\_4

The Disk Server Card has different firmware than a CPU Card. This allows it to handle all system disk functions. It is connected to an adjacent Local Memory Card with a ribbon cable. A Small Computer System Interface (SCSI) Adapter may be added for use with 9-track

tape and optical disk units (Refer to Section 4, MCS Options, for information concerning this adapter).

Configure the Disk Server Card by setting the jumpers as shown in Figure 3-6.

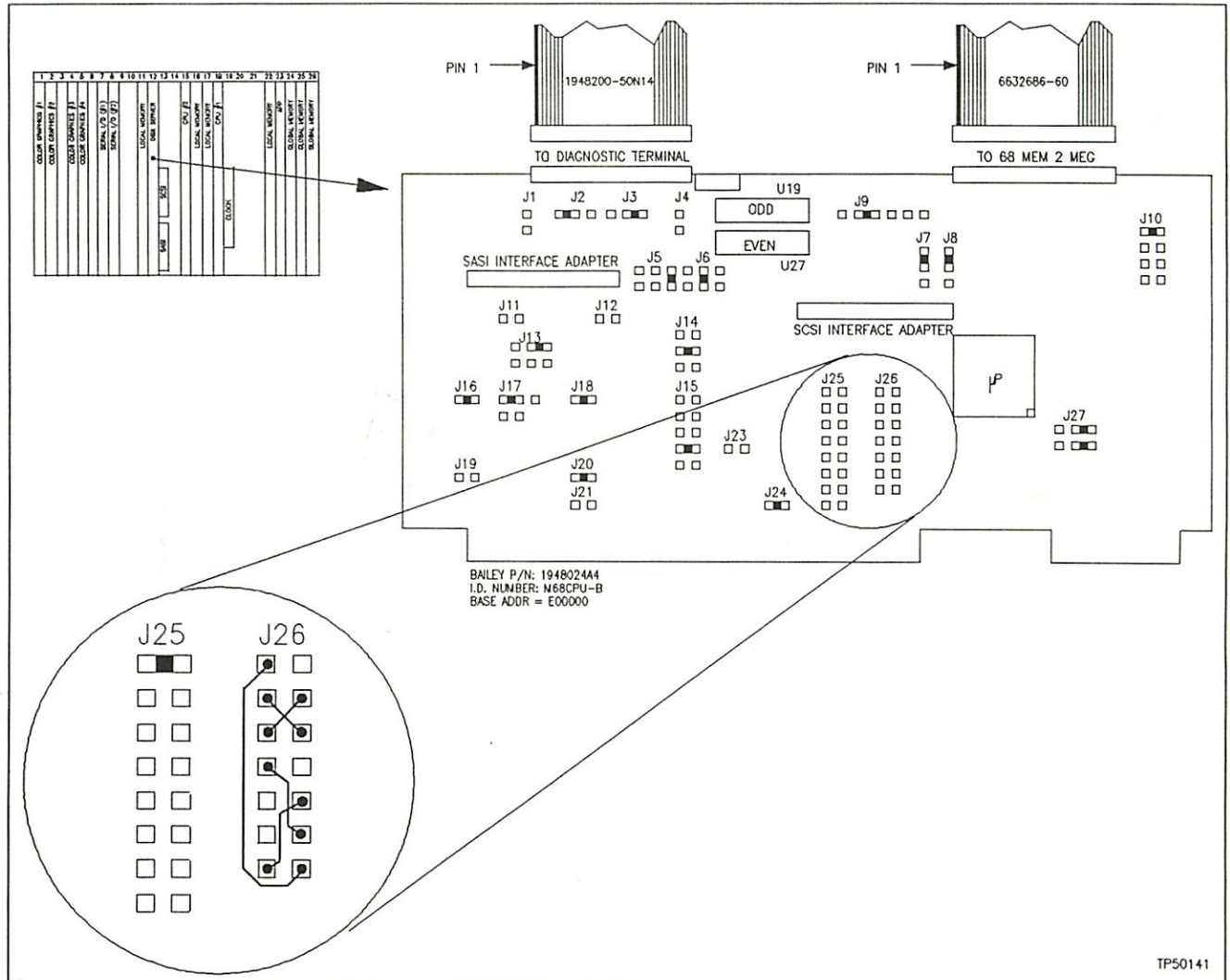

Figure 3-6. Disk Server Card

**SASI Disk Bus Interface Adapter**  
Bailey P/N - 1948023\_1

**MULTIBUS CARD CONFIGURATIONS**

The Disk Bus Interface Adapter provides the Shugart Associates System Interface (SASI) between the disk drives and the Disk Server Card. Shown in Figure 3-7, it attaches to the Disk Server Card and occupies physical space allotted to slot 13.

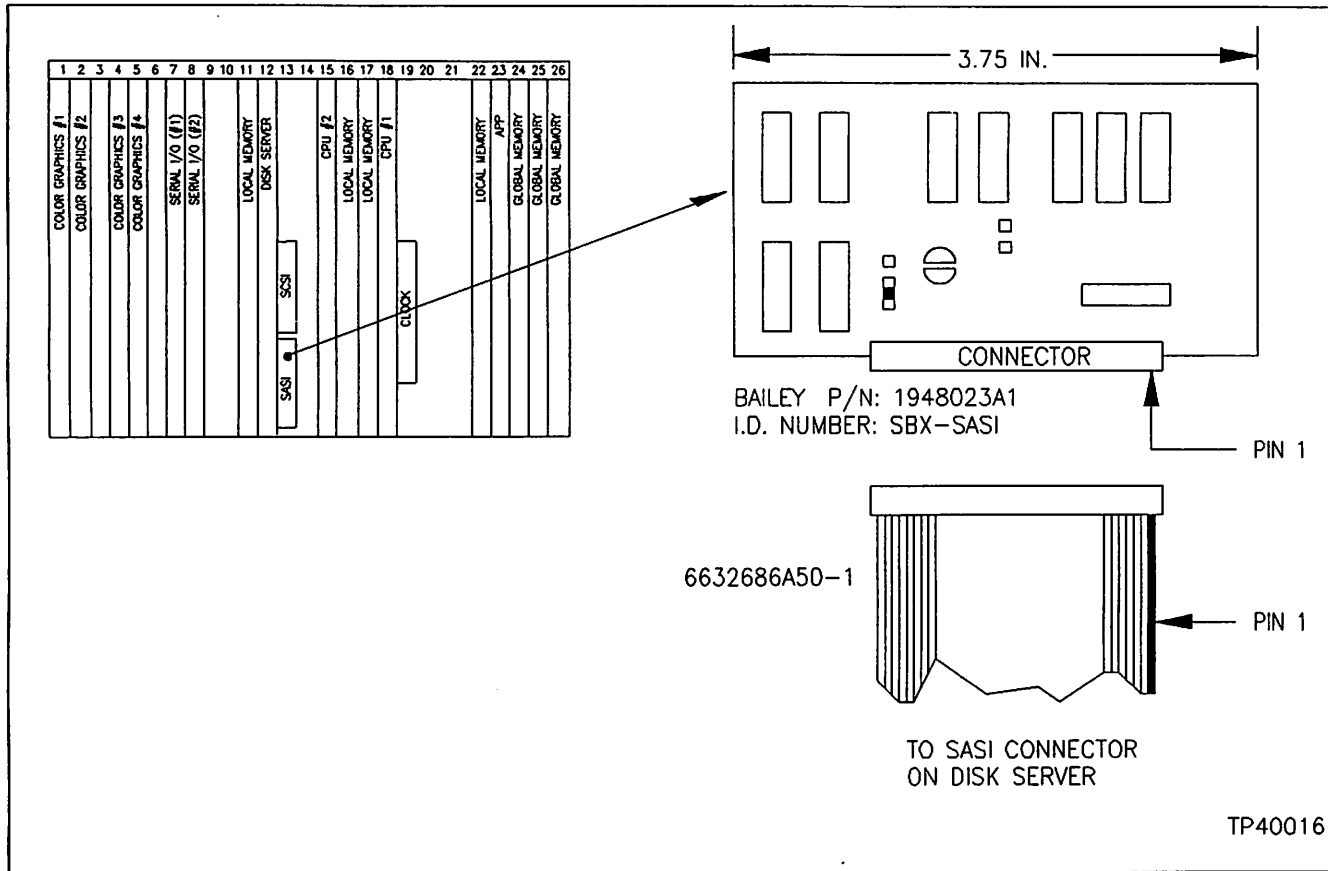

Figure 3-7. SASI Disk Bus Interface Adapter

# MULTIBUS CARD CONFIGURATIONS

## Local Memory Card Bailey - P/N 6637447\_1

Each MCS CPU Card (including the Disk Server Card) requires 2 Megabytes of local memory. A Local Memory Card is connected to each CPU card via a ribbon cable. This card contains 2 MEG of total on-board RAM. Refer to Figure 3-8 when setting jumpers J1 through J9 on these cards. These jumper settings apply to the memory cards for all CPU cards.

NOTE: Some users may have memory cards containing 4 Megabytes of RAM. Jumper settings differ on these cards (Figure 3-8). This card is the same card used for the 2 Megabytes RAM card, but with all RAM chip sockets filled.

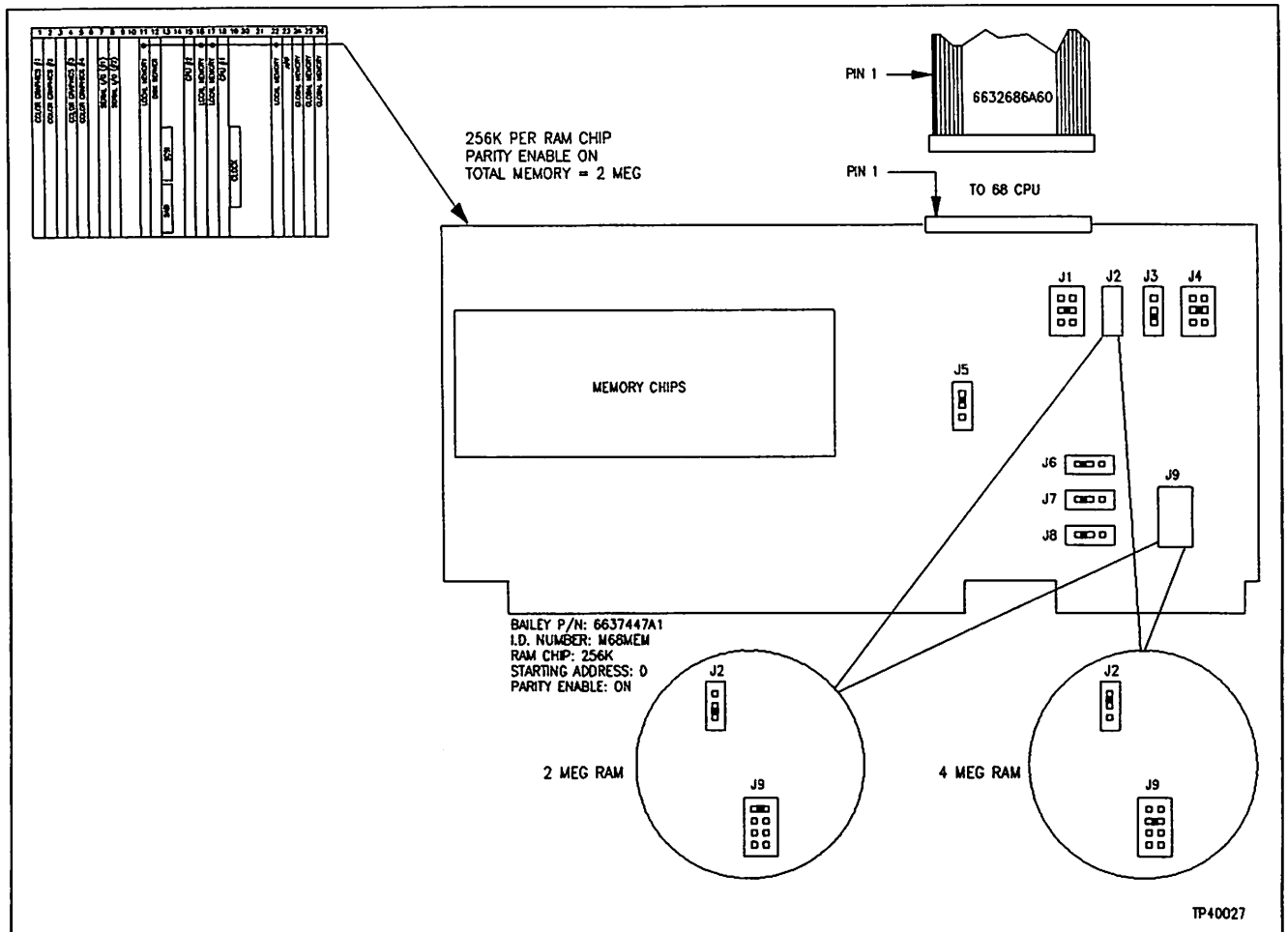

Figure 3-8. Local Memory Card

## CPU Card

Bailey P/N - 6637033\_2 (CPU Card 1 - Slot 18)  
6637033\_3 (CPU Card 2 - Slot 15)

The CPU card can access up to 2 MEG of RAM from the adjacent memory card connected by a ribbon cable. It contains Electrically Erasable Programmable Read Only Memory (EPROM) with a total storage capacity of 64 K bytes, and connection ports to a diagnostic terminal and the clock/calendar card. Refer to Figure 3-9 when setting the jumpers on CPU Card 1 or 2.

## MULTIBUS CARD CONFIGURATIONS

NOTE: Figure 3-9 applies only to systems manufactured after February 1, 1986, which have a backplane connected electronic reset switch. Contact your nearest Bailey Sales or Service office for information on units made previous to this date.

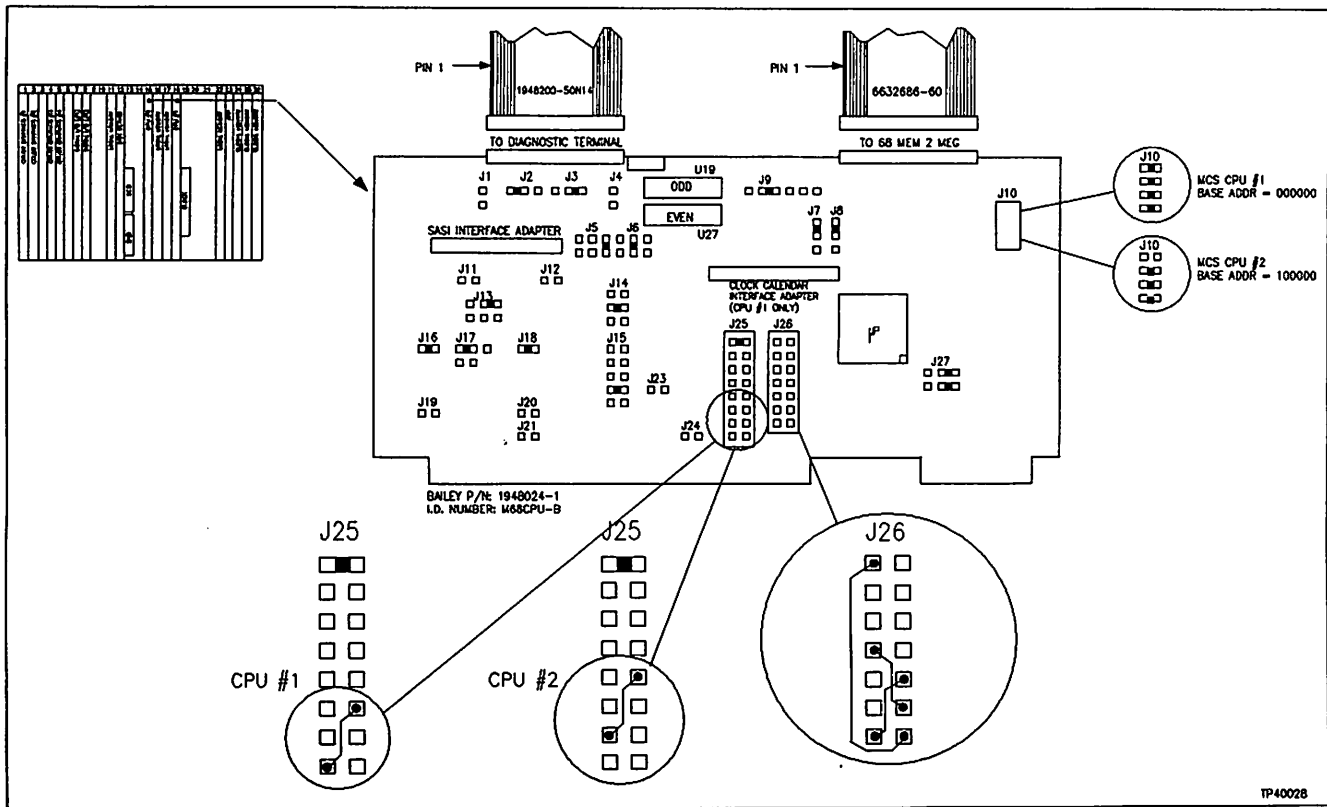

Figure 3-9. CPU Cards 1 and 2



## MULTIBUS CARD CONFIGURATIONS

### Clock Calendar Card Bailey P/N -1947999\_1

The Clock Calendar Card gives the MCS real time capability. This card has an on-board battery if a power backup is ever needed. The Clock Calendar Card, shown in Figure 3-10, resides on the CPU card and occupies physical space allotted to slot 19.

**NOTE:** If the MCS or replacement Clock/Calendar cards are stored for a duration of one week or more, remove the jumper located next to the battery (Figure 3-10). Failure to do so will result in excessive battery drain.

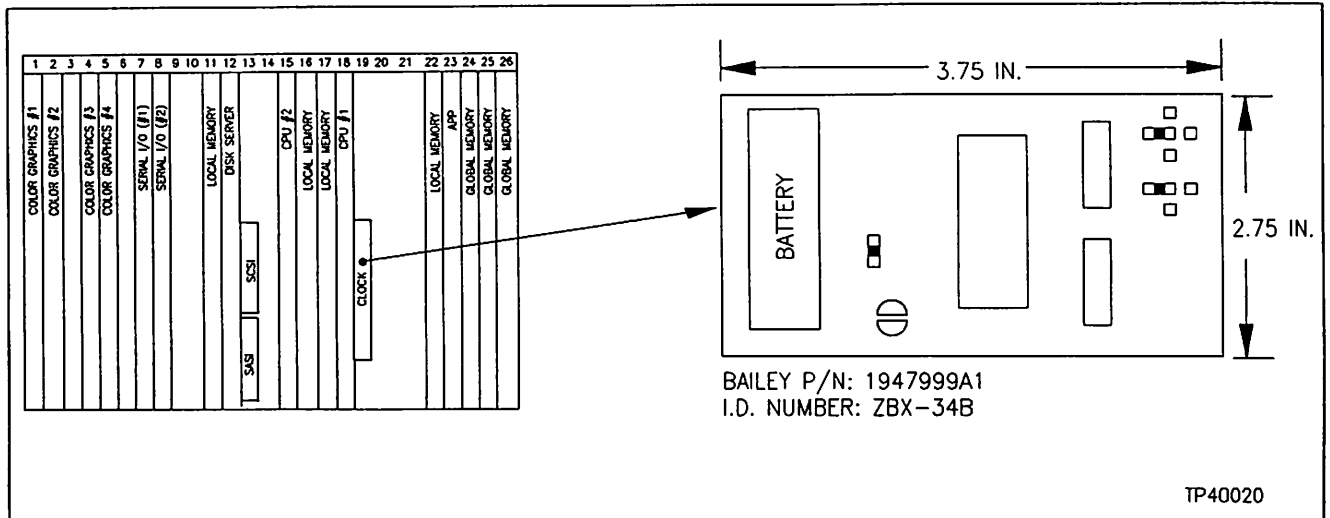

Figure 3-10. Clock Calendar Card

**Global Memory Card - I.D. Number: PSM-2P**

Bailey P/N - 6637446\_7 - Global Memory Card 1  
 6637446\_8 - Global Memory Card 2  
 6637446\_9 - Global Memory Card 3

**MULTIBUS CARD CONFIGURATIONS**

Global Memory cards provide memory accessible by the entire MCS system. Two versions are currently in use: I.D. Number PSM-2P and INTEL SBC020EX (Figure 3-11 and 3-12). Three cards are required, and may consist of either version. Configure the cards by setting jumpers and dipswitches.

NOTE: Where both types of Global Memory Cards are present, the same type must be grouped side-by-side, in contiguous memory locations. For the Intel SBC020EX, the E15 - E16 jumper (Figure 3-12) must be installed in the memory card in the highest address range. For example, if an Intel SBC020EX is installed in slot 24 and slot 25, and a PSM-2P is installed in slot 26, the Intel SBC020EX in slot 25 requires a jumper on E15 - E16.

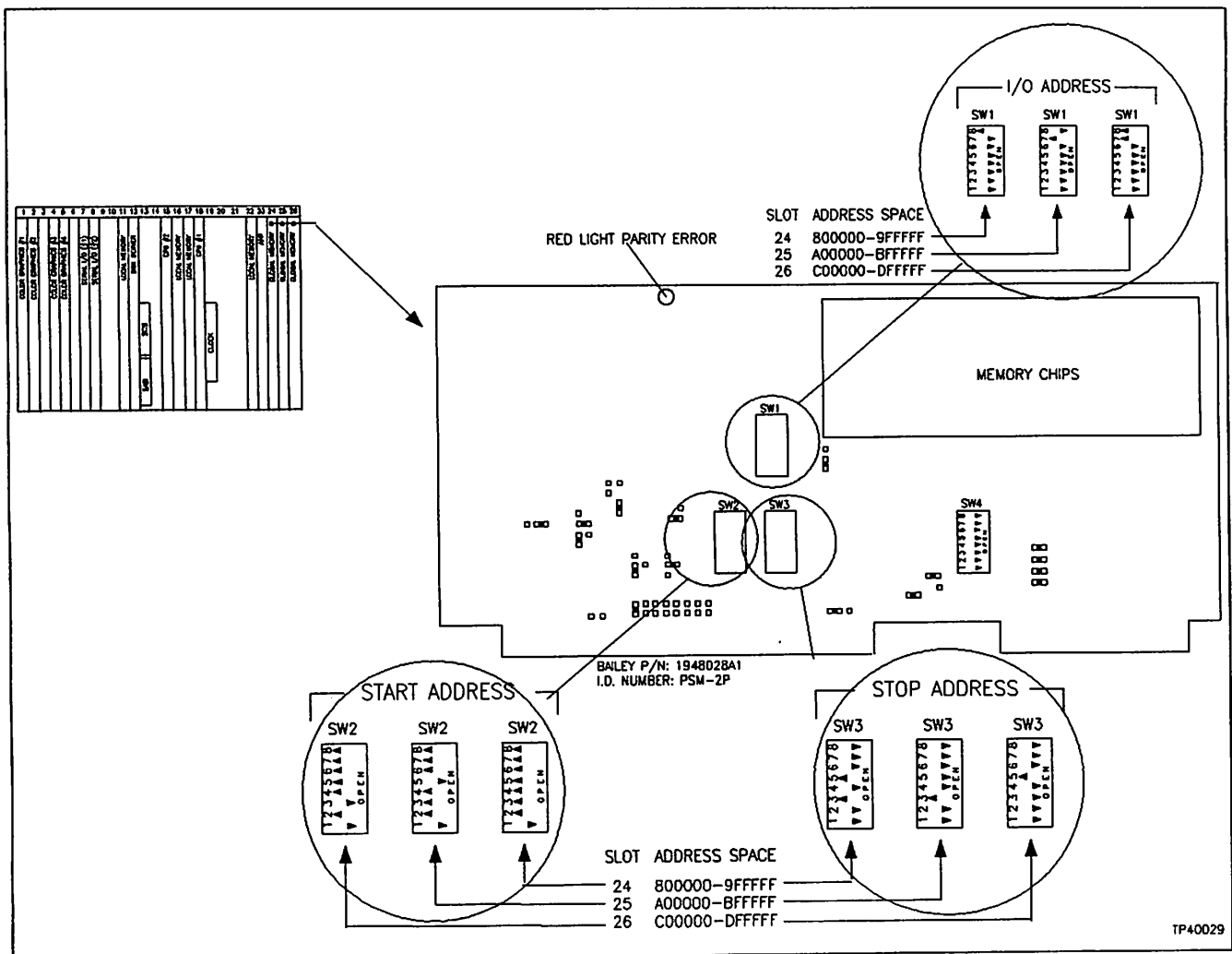

Figure 3-11. 2 MEG RAM Memory Card (ID Number PSM-2P)

# MULTIBUS CARD CONFIGURATIONS

## Global Memory Card I.D. Number: INTEL SBC020EX

Bailey P/N - 6637446\_7 - Global Memory Card 1  
 6637446\_8 - Global Memory Card 2  
 6637446\_9 - Global Memory Card 3

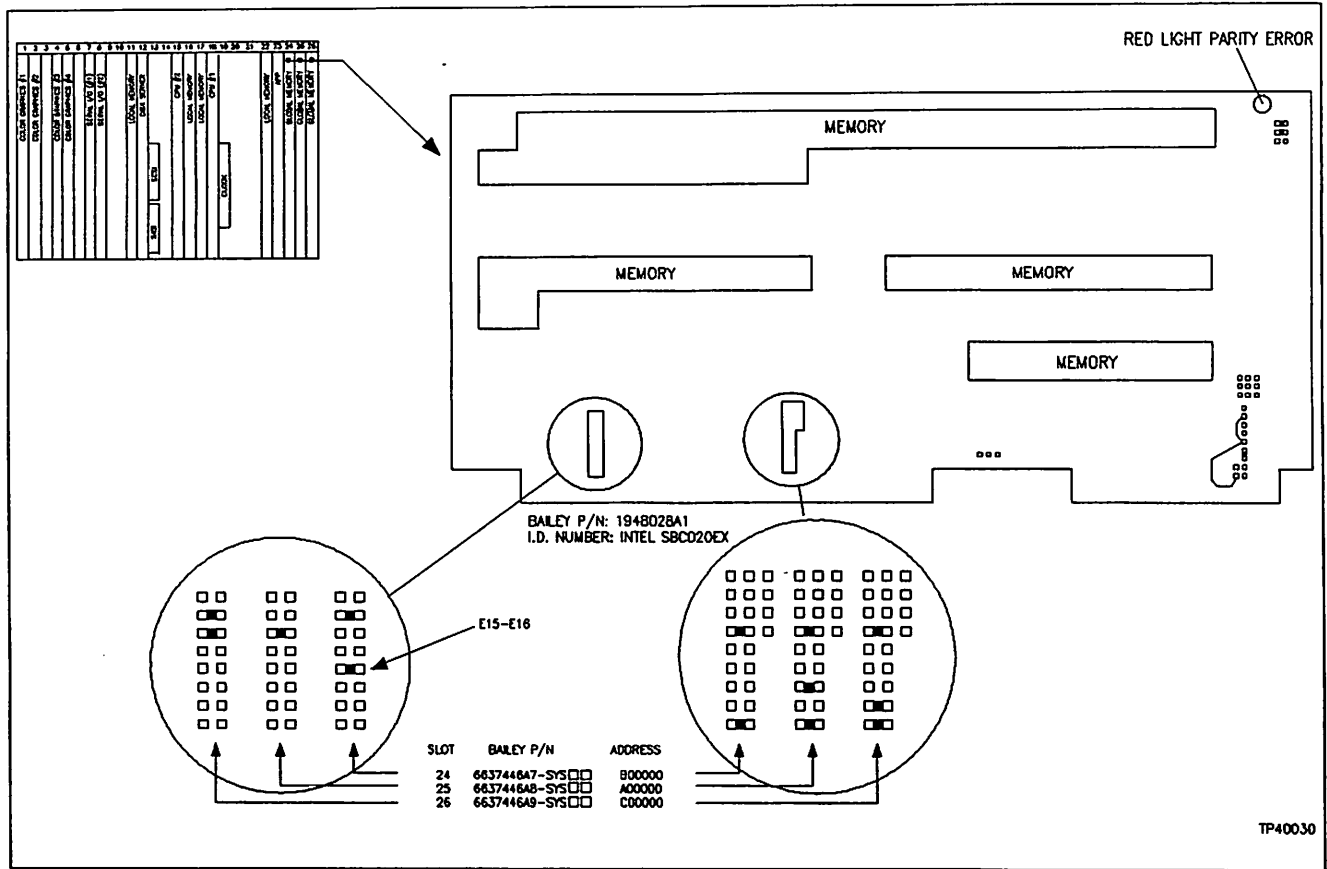

Figure 3-12. 2 MEG RAM Memory Card (I.D. Number INTEL SBC020EX)

## MODULE MOUNTING UNIT (MMU)

Bailey P/N - NMMU02

The Module Mounting Unit provides power and communication paths for the NETWORK 90 modules used by the MCS. Refer to Figure 3-13, Figure 3-14 and Table 3-5 when connecting power to the MMU.

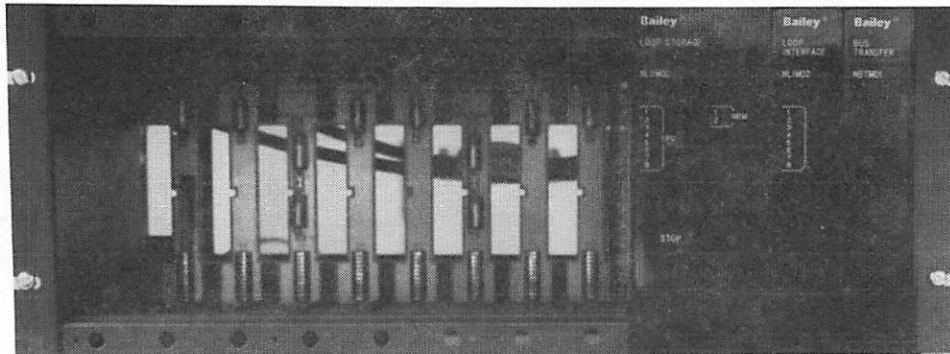

Figure 3-13. Module Mounting Unit - Front View

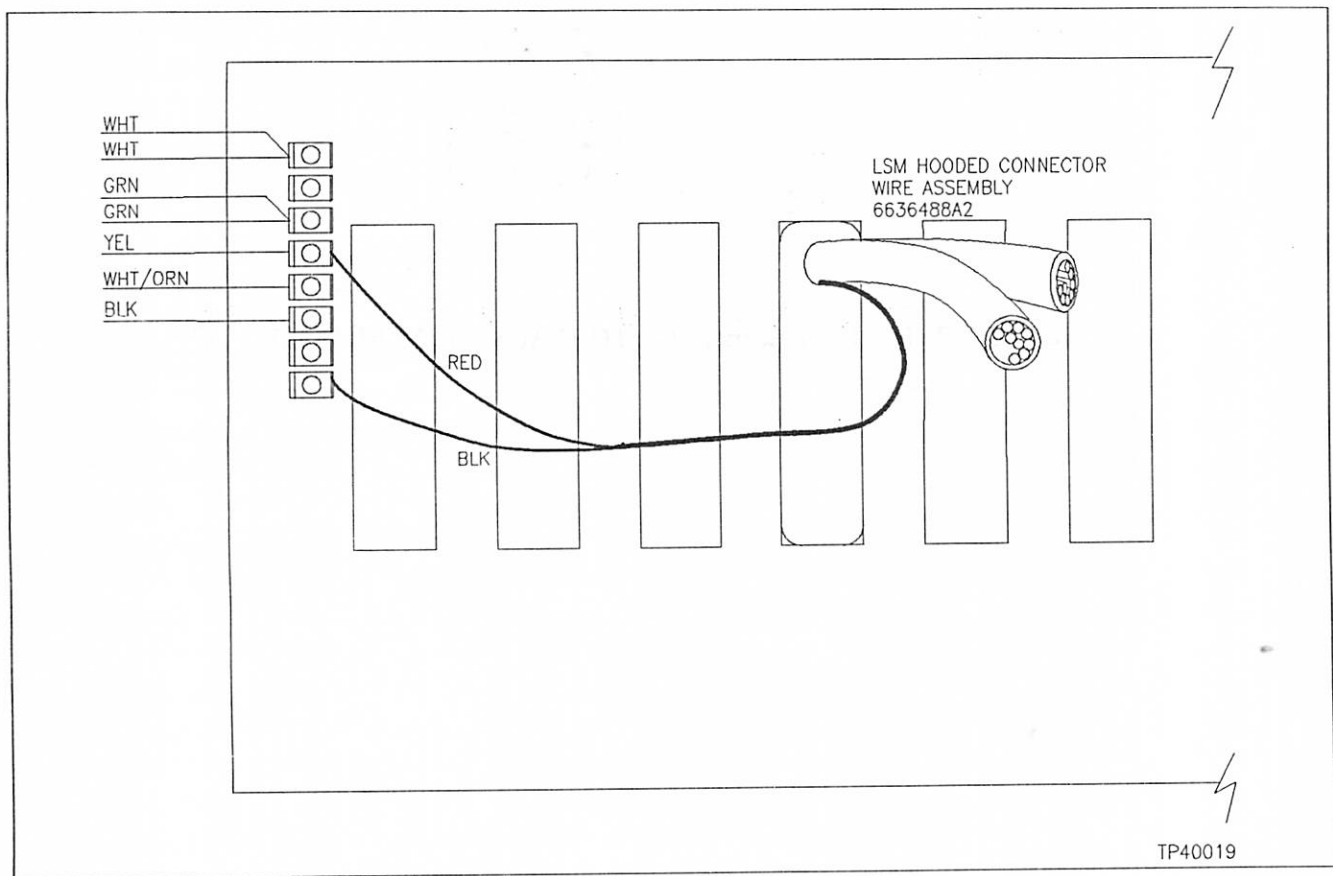

Figure 3-14. Module Mounting Unit - Back View Wiring Connections

**MODULE MOUNTING UNIT (MMU)**  
Bailey P/N - NMMU02

*Table 3-5. Wiring Connections to MMU Backplane Tabs*

Tab Number	Assignment	Wire Type
1	+5 V dc to terminals 11 and 12 of TB1 at top of the System. Power Supply	2 white wires <sup>1</sup>
2	no connection	-----
3	COMMON to terminals 9 and 10 of TB1 at top of the System. Power Supply	2 green wires <sup>1</sup>
4	+ 15 V dc to J3 socket at top of the System Power Supply. + 15 V dc to NLSM02 wire assembly	1 yellow wire <sup>2</sup> 1 red wire <sup>3</sup>
5	- 15 V dc to J3 socket at top of the System Power Supply.	1 white/orange wire <sup>2</sup>
6	Power Fail Interrupt (PFI) to J3 socket at top of the System Power Supply.	1 black wire <sup>2</sup>
7	no connection	-----
8	Signal Common to NLSM02 wire assembly	1 black wire <sup>3</sup>
<p><b>NOTES:</b></p> <ol style="list-style-type: none"> <li>1. Wire assembly 6636491_2 - Plugs into the TB1 socket at top of the System Power Supply.</li> <li>2. Wire assembly 6636492_2 - Plugs into the J3 socket at top of the System Power Supply.</li> <li>3. Wire assembly 6636488_2 - Hooded connector attaches to J3 (Center PCB connector) of the NLSM02. A red and black wire extend from the hood to tab 4 and 8 of the MMU.</li> </ol>		

---

## NETWORK 90 MODULES

The NETWORK 90 modules used with the MCS are provided to allow the MCS to communicate with Process Control Units (PCUs) and other operator consoles. The modules included are the Loop Interface Module, the Bus Transfer Module, and the Loop Storage Module. Each module is configured using dipswitches and jumper settings.

**NOTE:** If your system interfaces with super-loop, refer to Section 4, MCS Options.

### Installation

The modules insert into the Module Mounting Unit along guide rails at the top and bottom of the interior frame. Each is secured in place by a lower latch. Slide the module into the desired position being careful to align the card edges into the guides. When the module is fully inserted, the latch snaps into the bottom of the rack.

### Removal

Remove a module by depressing the latch and gently pulling it out of the MMU.

## NETWORK 90 MODULES

### Loop Interface Module Bailey P/N - NLIM02

The Loop Interface Module (NLIM02) allows communication between the MCS Bus Transfer Module and other Process Controls Units (PCUs) and operator consoles. Refer to Figure 3-15 to configure this module by setting jumpers and dipswitches. For additional information on this module, refer to Bailey manual E93-908-1.

NOTE: Dipswitch S2 selects the loop address of this MCS and depends on your individual system.

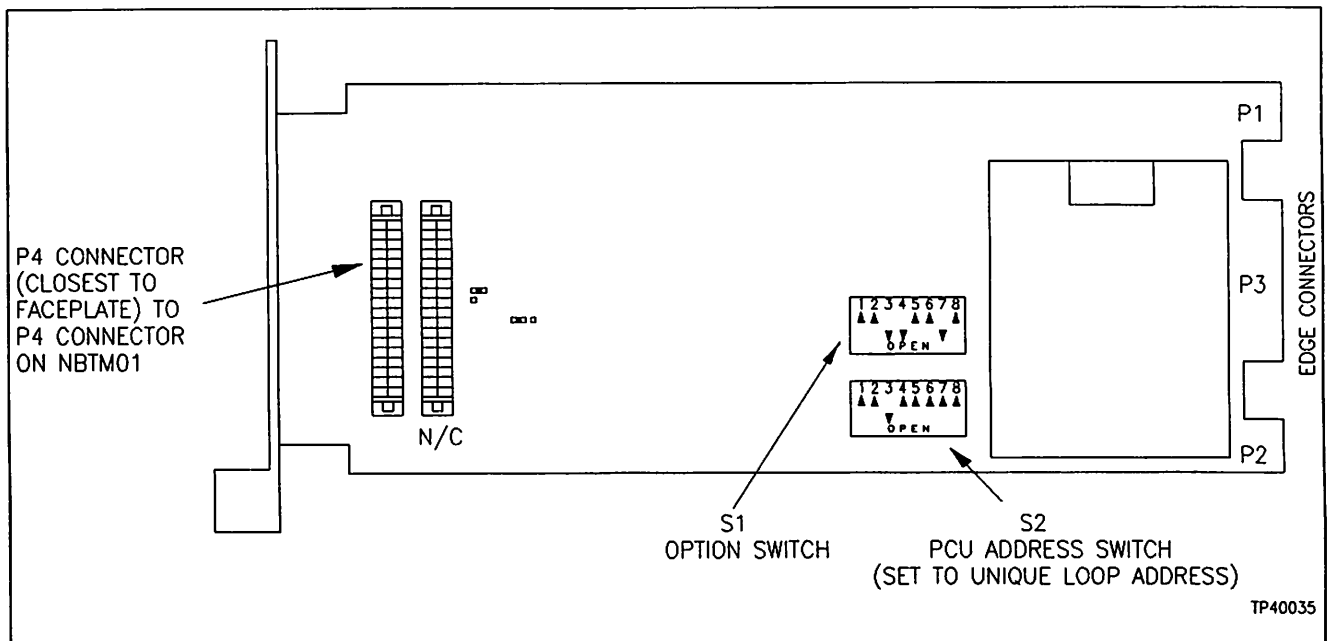

Figure 3-15. Loop Interface Module Configuration

**Bus Transfer Module**

Bailey P/N - NBTM01

**NETWORK 90 MODULES**

The Bus Transfer Module (NBTM01) provides communication between the Loop Interface Module and Loop Storage Module across the MMU data bus. Refer to Figure 3-16 to

configure this module by setting jumpers and dipswitches. For additional information on this module, refer to Bailey Product Instruction E93-908-1.

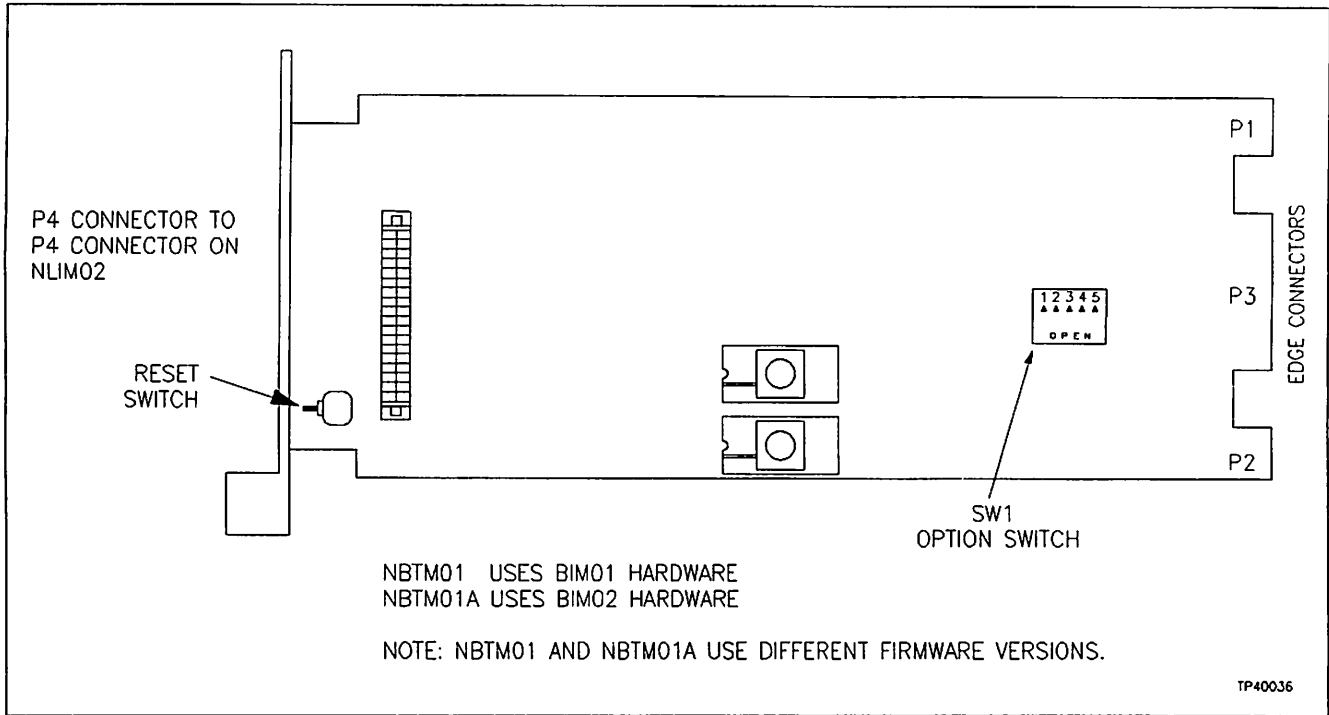

*Figure 3-16. Bus Transfer Module Configuration*



## NETWORK 90 MODULES

### Loop Storage Module Bailey P/N - NLSM01, NLSM02

The Loop Storage Module (LSM) contains a library of commands which provide a means of sending and retrieving data from other Process Control Units and operator consoles. The MCS sends commands to the Loop Storage Module (LSM) requesting it to send or retrieve required data. The LSM consists of two cards, a memory card and a CPU card. It is configured by setting dipswitches on the CPU card. Refer to Figure 3-17 for the standard module dipswitch settings. For more information on this module, refer to Bailey Product Instruction E93-905-8.

**NOTE:** If performing CIU diagnostics, dipswitch U75-3 must be in the down position (open). Refer to the CIU Programmers Reference Manual E93-905-9.

#### Cable Connection - Assembly 6636488\_2

Attach the hooded connector at the back of the MMU, slot position 9 (CPU board).

- J1 connects to AUX 1 on the I/O Distribution Board.
- J3 connects to a terminal for diagnostics when running tests on the NLSM02 (refer to the CIU Product Instruction E93-905-2).
- wire pair:

J4 connects to tab 4 (+15) on the MMU back-plane.

J5 connects to tab 8 (COM) on the MMU back-plane.

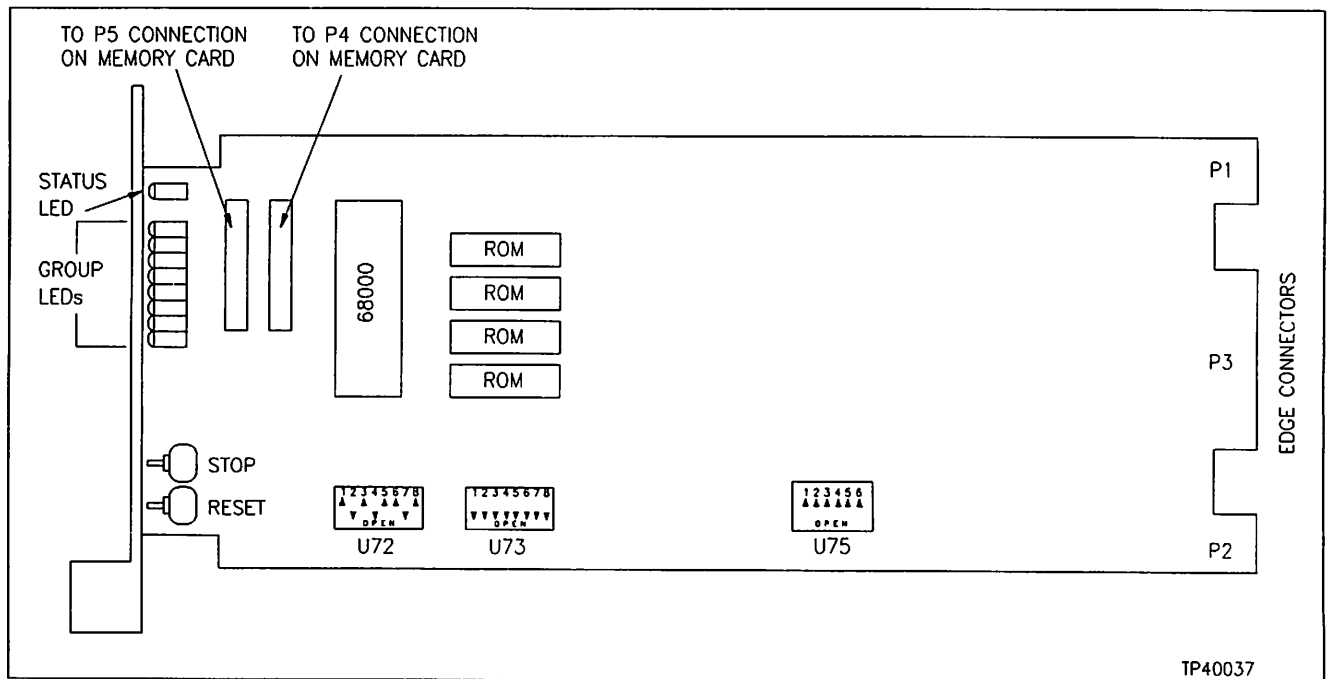

Figure 3-17. Loop Storage Module - NLSM02 (Bottom Board)

# AC DISTRIBUTION BOARD

Bailey P/N - 6636530\_1

The AC Distribution Board (Figure 3-18) contains the main AC power terminals, and distributes the AC throughout the MCS. Wiring connections are shown in Table 3-6. Note that

some of the connections are made behind the AC Distribution Board, and are not visible from the rear of the MCS.

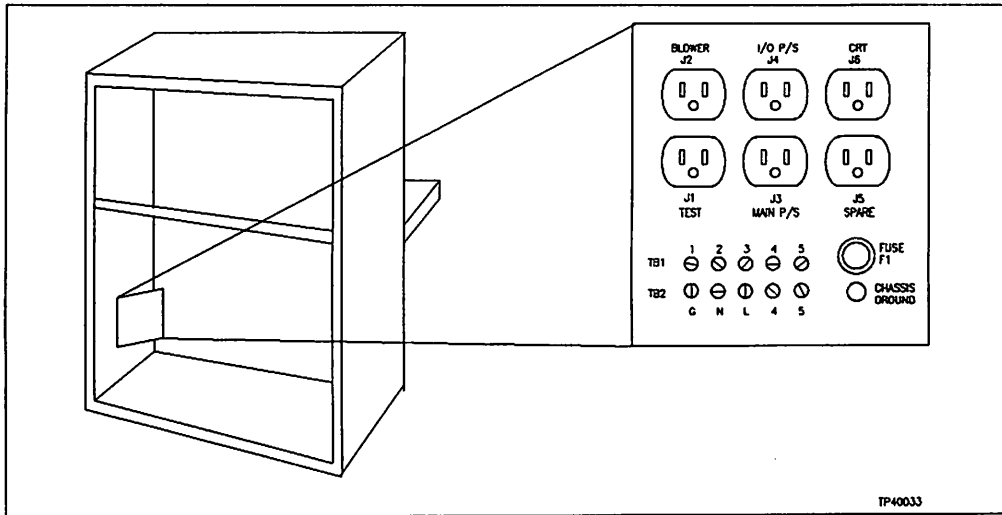

Figure 3-18. Location of AC Distribution Board

Table 3-6. Wiring Connections For AC Distribution Board

	1	2	3	4	
From TB1	12 AWG green wire to TB2, lug G 12 AWG green wire to J7 socket, lug 3	10 AWG black wire to TB2, lug L 10 AWG black wire to circuit breaker (CB1), lug 1	10 AWG white wire to TB2, lug N 10 AWG white wire to circuit breaker (CB1), lug 3	10 AWG white wire to filter 1, lug 2 10 AWG white wire to circuit breaker (CB1), lug 4	
	G	N	L	4	5
From TB2	12 AWG green wire to ground 10 AWG green wire to J5 socket, lug 3 12 AWG green wire to TB1, lug 1	10 AWG white wire to TB1, lug 3	10 AWG black wire to TB1, lug 2	12 AWG black wire to filter 1, lug 3 12 AWG black wire to J8 socket, lug 1	12 AWG white wire to J5 socket, lug 2 12 AWG white wire to J8 socket, lug 2
From Chassis Ground	12 AWG green wire to TB2, lug G 12 AWG green wire to filter 1, lug 5				

## CIRCUIT BREAKER (CB1) - 120 V AC

Bailey P/N - 1946949\_7

The circuit breaker (CB1) provides over current protection and a means of removing power from the MCS. Table 3-7 provides

wiring information. Note that the illustration in Figure 3-19 shows the rear view of the circuit breaker.

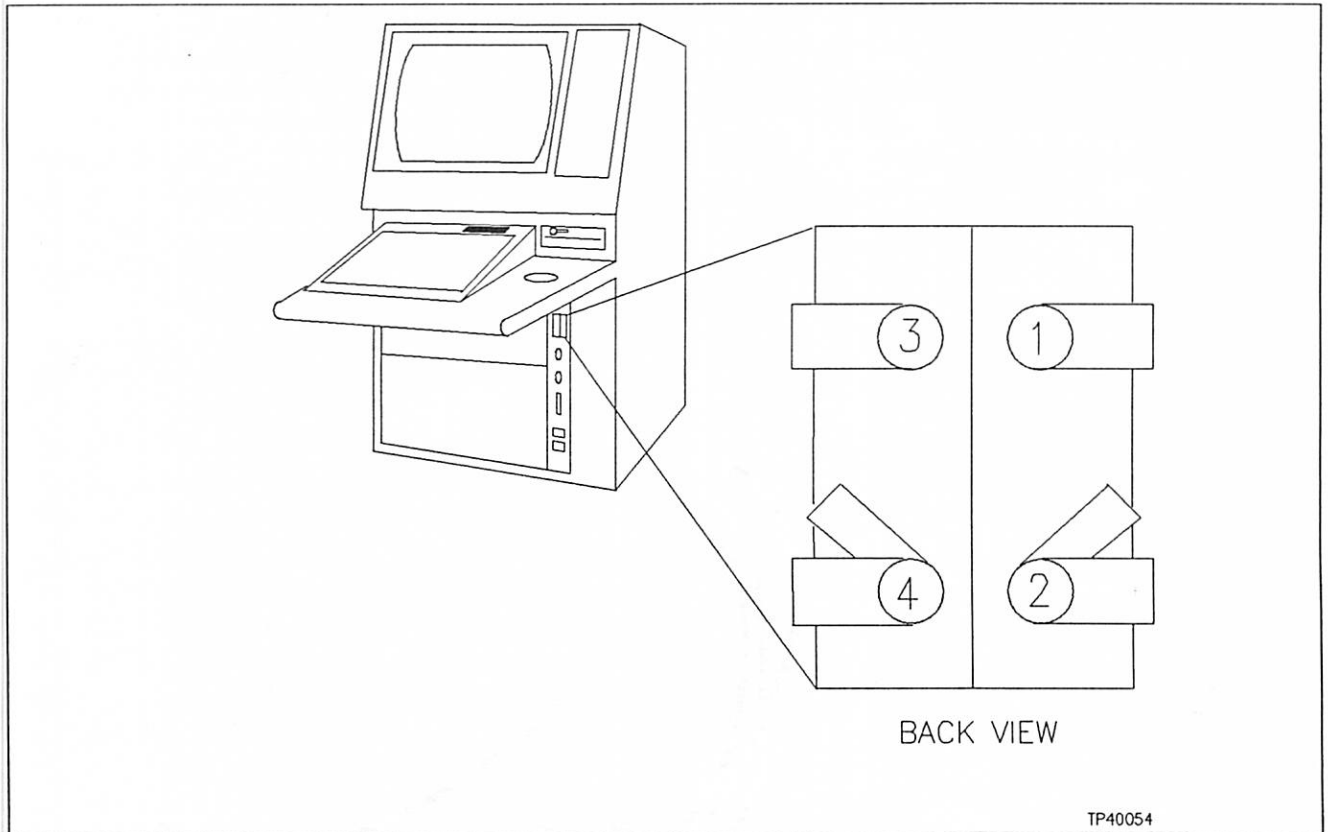

Figure 3-19. Location of 120 V AC Main Circuit Breaker (Rear View)

Table 3-7. Wiring Connections to 120 V AC Main Circuit Breaker

Lug Number			
1	2	3	4
10 AWG black wire to TB1, lug 2	To Power Status Light, lug 1  10 AWG black wire to TB1, lug 4	10 AWG white wire, to TB1	To Power Status Light, lug 2 lug 3  10 AWG white wire to TB1, lug 5

## COLOR MONITOR

Bailey P/N - 6636994\_1

The color monitor used in the MCS is an RGB monitor with a 640 X 480 pixel resolution CRT. Table 3-8 shows wiring connections.

### NOTES:

1. Cable number 6636503 connects the monitor to the I/O Distribution Board. Labels R, G, and B represent red, green, and blue, respectively.

2. Maximum length of RS-170 RGB Cables is 100 feet. For distances over 100 feet, optical modems (NREM01) using up to 1000 feet of fiber optic cable (NKFM01-xx) are required.

3. If remote CRTs are being installed, ensure they are powered using the same polarized power and ground as the MCS to prevent ground loops. Failure to do so may cause display distortion. If ground loops are still suspected, use of optically isolated modems will eliminate the problem.

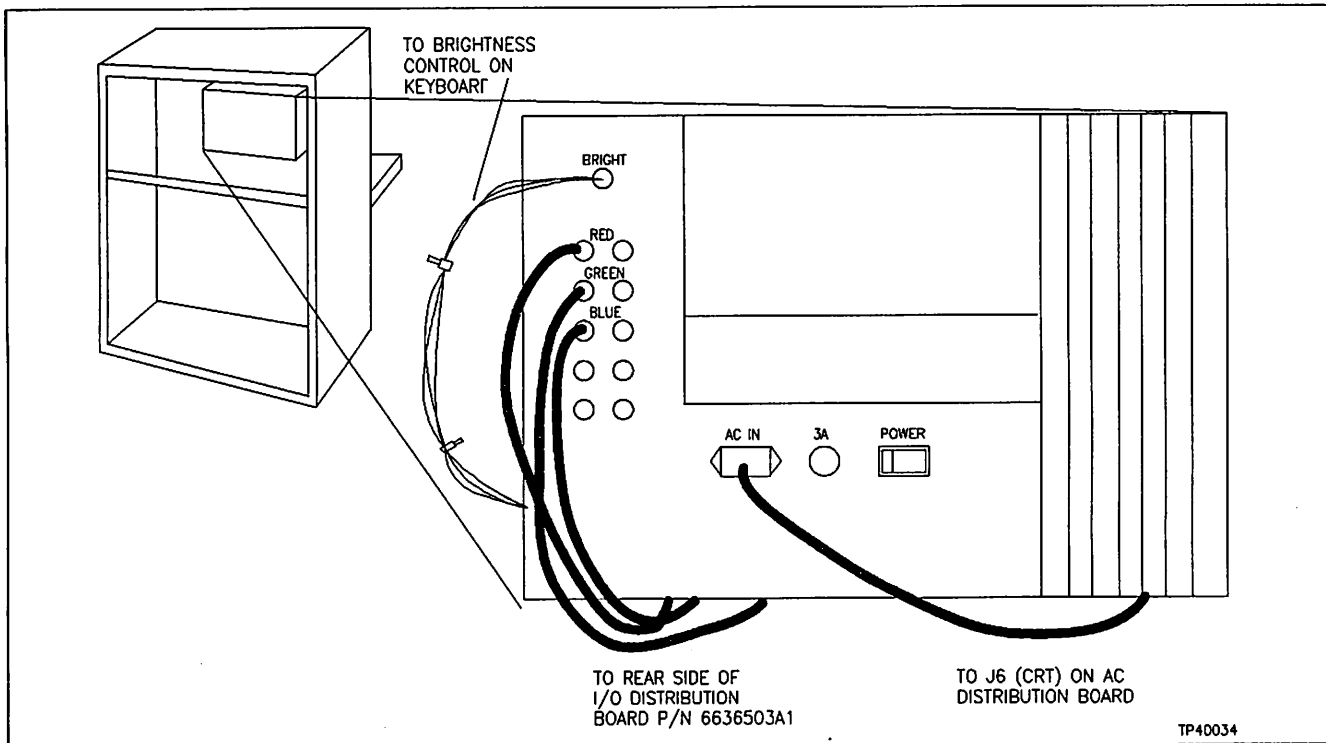

Figure 3-20. Location of Color Monitor

Table 3-8. Connections to Color Monitor

Video Inputs			
RED	GREEN	BLUE	AC POWER
Connect to red terminal (1 R) on front of I/O Distribution board	Connect to green terminal (1 G) on front of I/O Distribution board	Connect to blue terminal (1 B) on front of I/O Distribution board	Plug into J3 socket on AC Distribution board

The DIN board attaches to the MCS keyboard and provides two auxiliary user ports. The DIN socket accepts an IBM PC/XT or compatible style keyboard. A user RS232 serial port is available for foreign language keyboard.

**NOTE:** Some keyboards may have two underside switches. Set switch 1 to the ON position and switch 2 through 8 to the OFF position (fixed XT mode).

*Table 3-9. Connections to DIN Board*

From P1	From P2	From P3
To P5 connector on main keyboard controller card	To Keyboard connector	Not used at this time

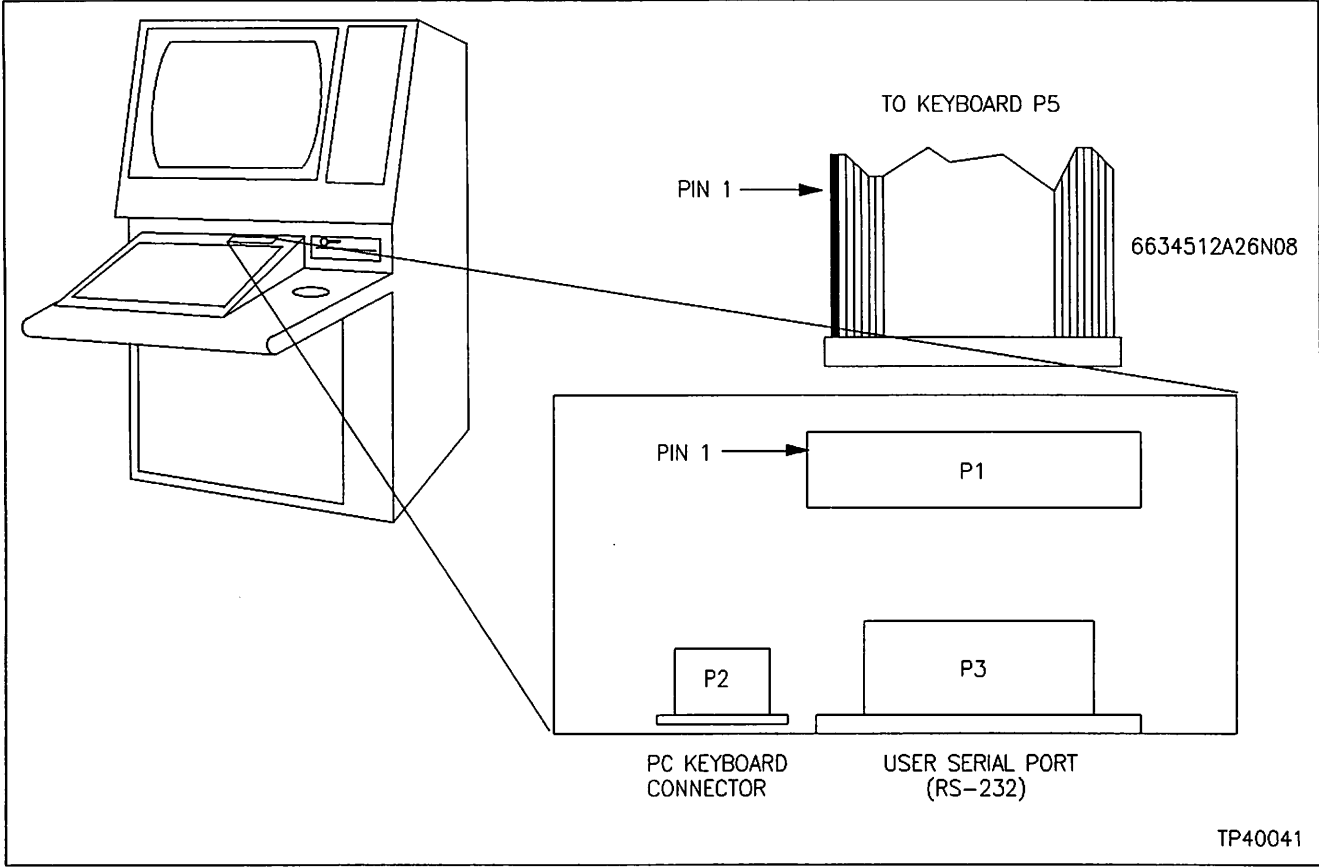

*Figure 3-21. Location of DIN Board*

# I/O DISTRIBUTION BOARD

Bailey P/N - 6636361\_1

The I/O Distribution Board (Figure 3-22) provides the interface for all input and output devices associated with the MCS. Each port on the I/O Distribution Board is assigned an input or output device. Refer to Table 3-10 for the port assignments.

Jumpers JMPR1 through JMPR16 are normally installed. When these jumpers are removed,

serial card ports P21R through P24R become electrically equivalent to ports P21 through P24 respectively.

**NOTE:** Due to software enhancements, the assigned functionality of some RS-232 ports have changed. Figure 3-22 shows the correct port assignments. These may not agree with the actual labeling on your MCS.

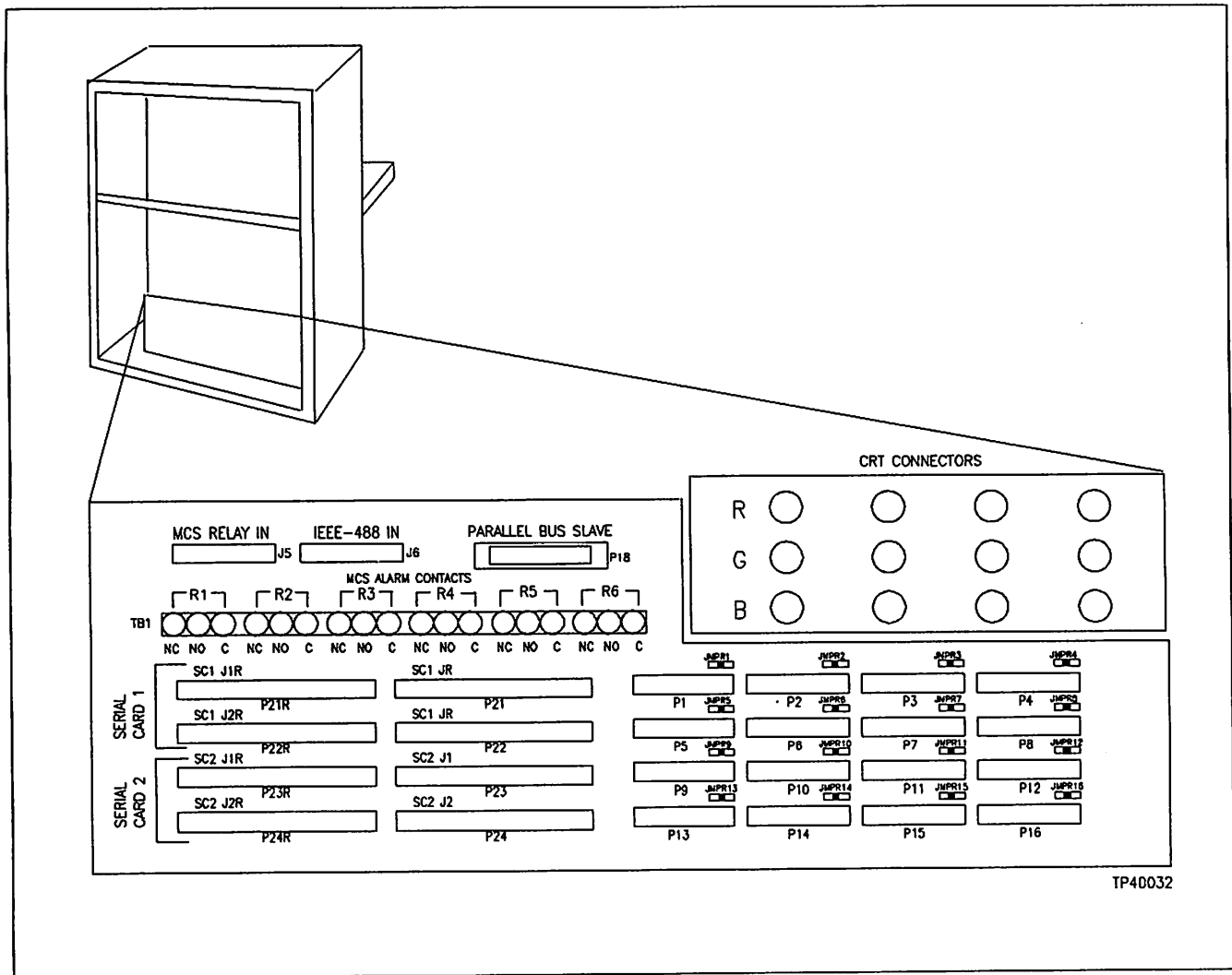

TP40032

Figure 3-22. Location of I/O Distribution Board

*Table 3-10. I/O Distribution Board Assignments*

<b>Connector</b>	<b>Function</b>
MKI Relay	Connects to P9 connector on main keyboard controller card
IEEE-488 IN	Not used at this time
Parallel Bus Slave	Not used at this time
R1 - R6	Connects to field relays: NC (normally closed), NO (normally open), C (closed)
P21R - P22R	Not used at this time
P21 - P22	Connects to intelligent serial interface card(s)
P23R, P24R, P23, P24	Not used at this time
P1, P2, P3, P6	Connection ports for keyboard 1, 2, 3, and 4 respectively
P5, P7	Connection ports for printer 1 and 2 respectively
P8	Diagnostic test port for the DDT
P9 - P16	Not used at this time

**Floppy Disk Drive - Teac**  
Bailey P/N - 1948018\_1

**FLOPPY DISK DRIVE**

The TEAC FD-55GFR-541-U and its jumper configuration is shown in Figure 3-25.

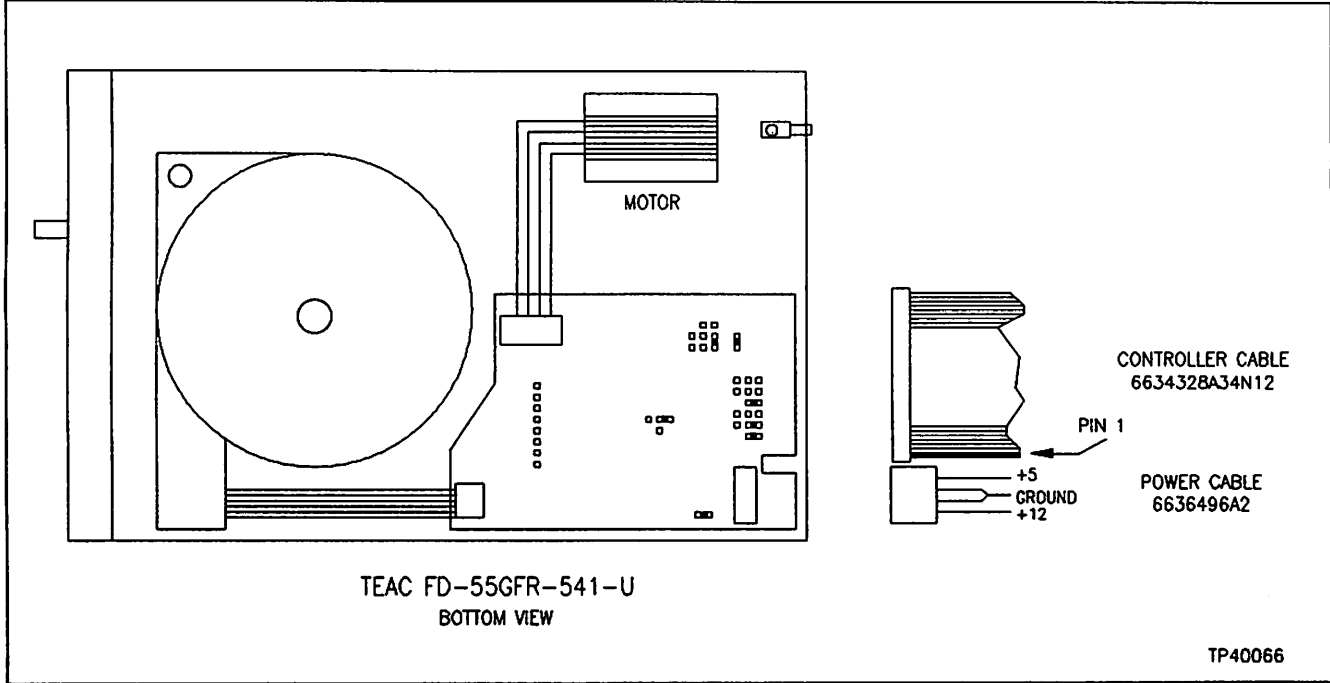

**Figure 3-25. TEAC Floppy Disk Drive**



**FLOPPY DISK DRIVE - TEAC**

**Floppy Disk Drive - Teac**  
Bailey P/N - 1946016\_1\*

The MCS uses a high density 1.2 Megabytes floppy disk drive. Five drive styles are used, and each requires configuration by setting

jumpers. The TEAC FD-55GF and FD-55GF-60-U and their jumper configuration are shown in Figure 3-24.

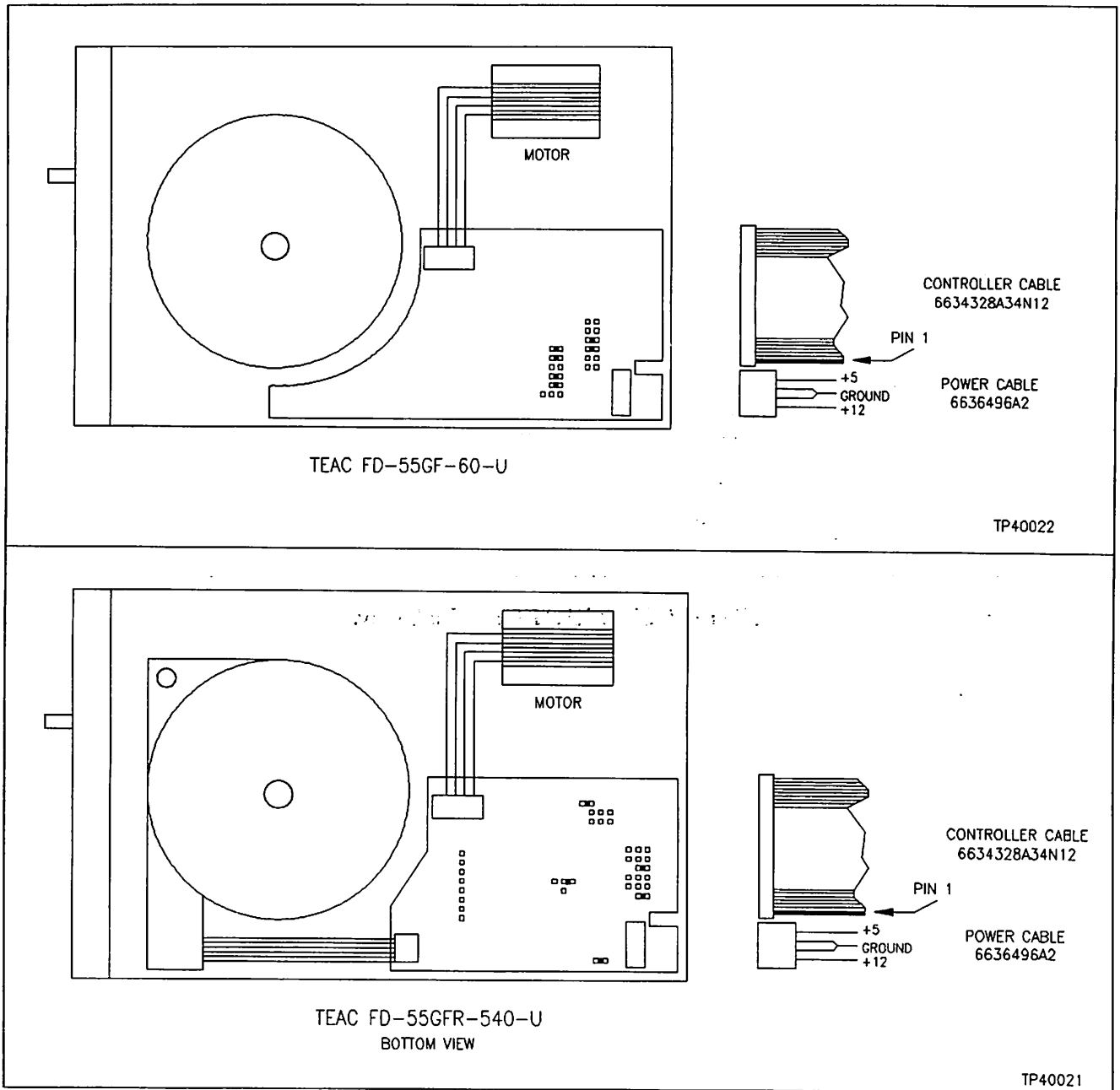
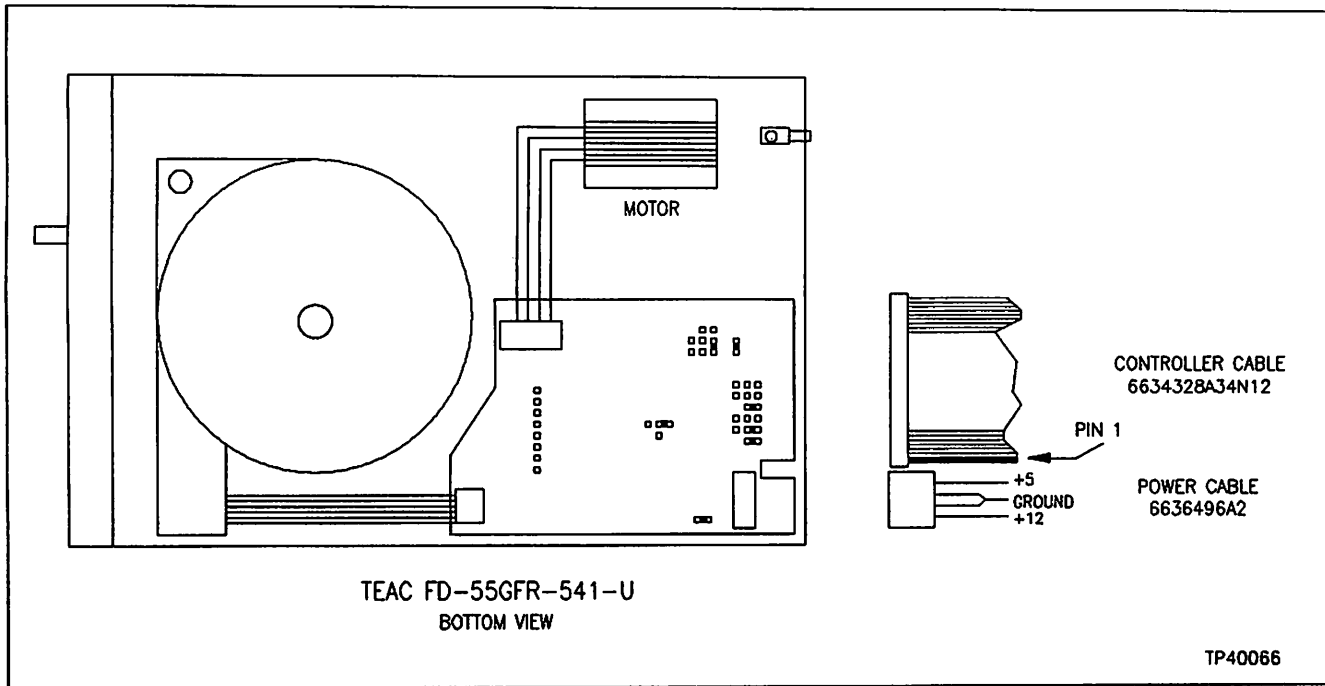

*Figure 3-24. TEAC Floppy Disk Drives*

**Floppy Disk Drive - Teac**  
Bailey P/N - 1948018\_1

**FLOPPY DISK DRIVE**

The TEAC FD-55GFR-541-U and its jumper configuration is shown in Figure 3-25.



**Figure 3-25. TEAC Floppy Disk Drive**

# FLOPPY DISK DRIVE

NEC  
Bailey P/N - 1948018\_1

The NEC FD 1155C and NEC FD 1157C and their jumper configuration are shown in Figure 3-26.

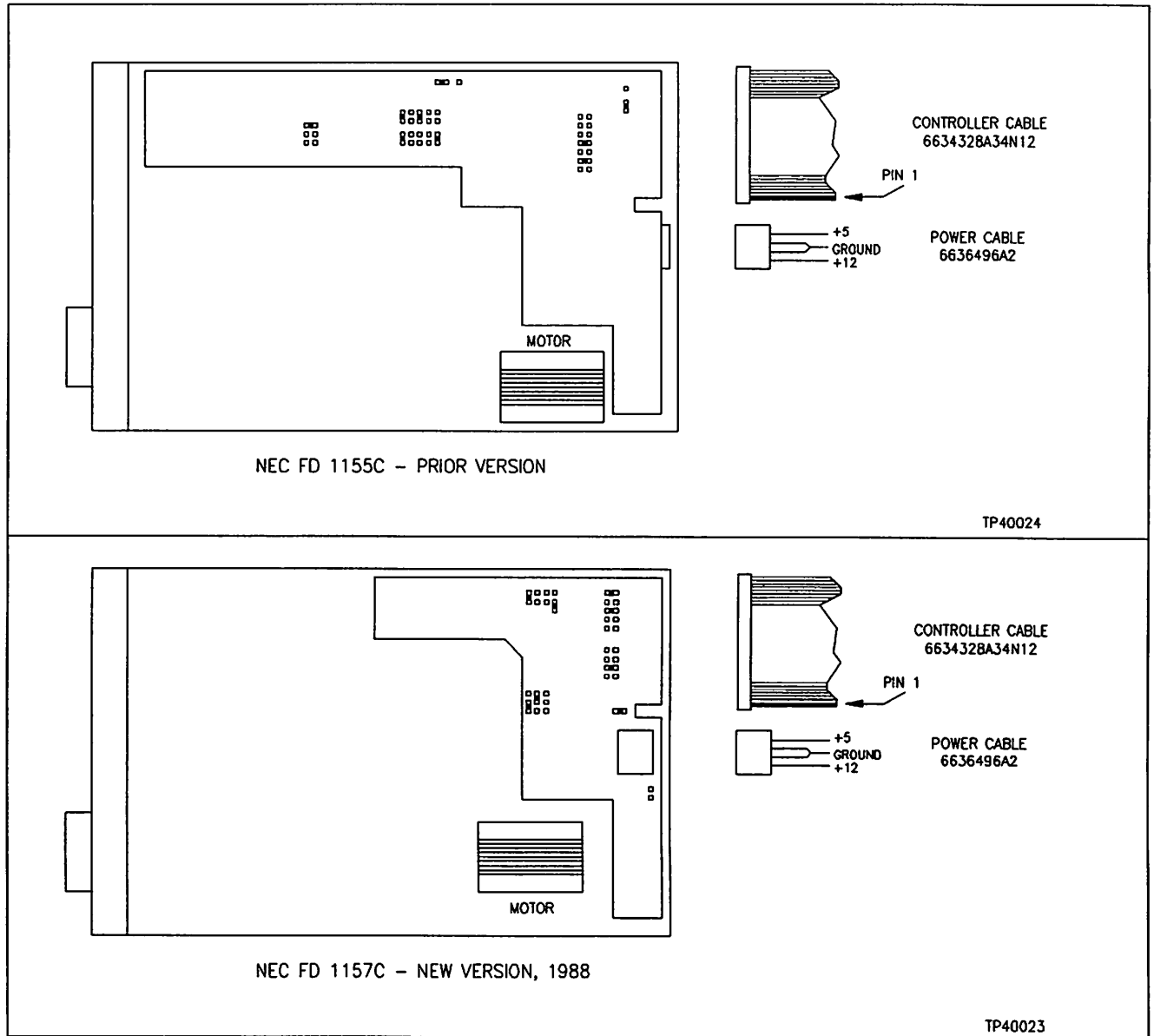

Figure 3-26. NEC Floppy Disk Drives

**CYNTHIA (BULL) 55 MBYTE**  
Bailey P/N - 1948002\_1

**HARD DISK DRIVE**

The MCS uses either the CYNTHIA® (BULL) hard disk, the VERTEX® PRIAM V150/V185 hard disk, or the PRIAM® V185A hard disk. All require jumpers to be set to configure the drive

for use with the MCS. Figure 3-27 shows the required jumper configuration for the CYNTHIA (BULL) hard disk drive.

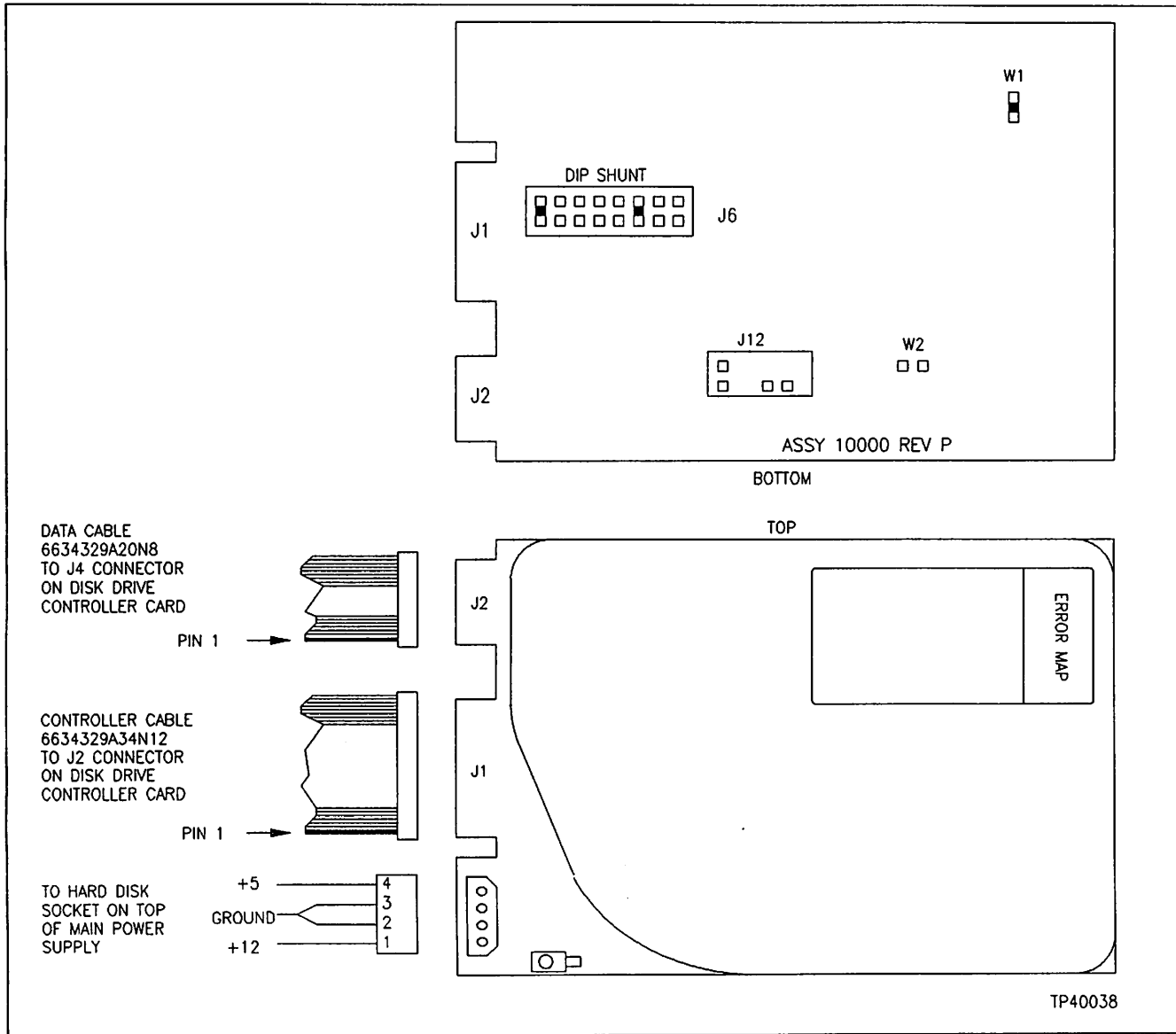

Figure 3-27. CYNTHIA (BULL) 55 Megabytes Hard Disk

© CYNTHIA is a registered trademark of Bull Peripherals.  
© VERTEX is a registered trademark of Vertex Electronics, Inc.  
© PRIAM is a registered trademark of Priam Corporation.

# HARD DISK DRIVE

VERTEX (PRIAM) V150/V185  
Bailey P/N - 1948002\_1

Figure 3-28 shows the required jumper configuration for the VERTEX hard disk drive.

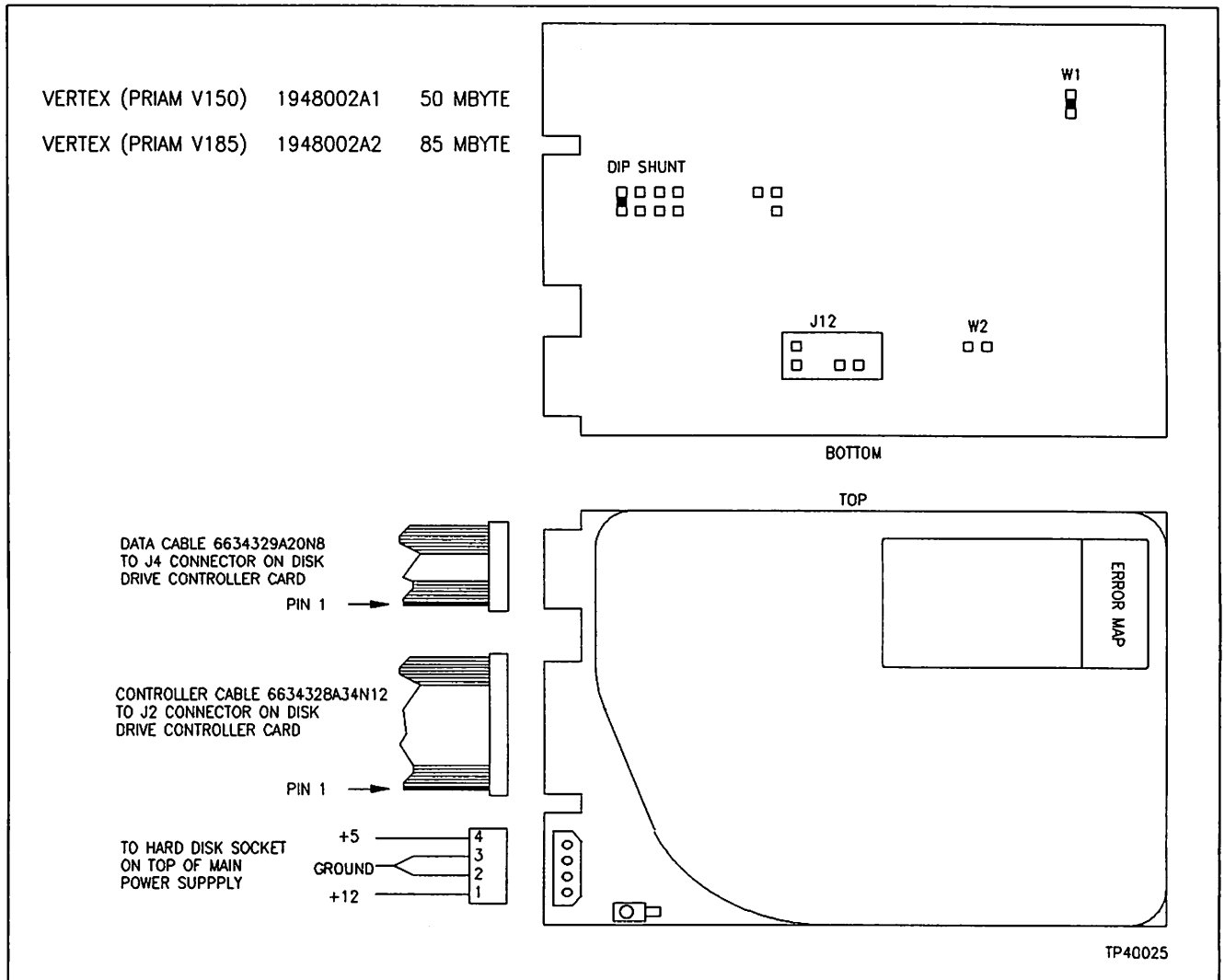

Figure 3-28. VERTEX (PRIAM) Hard Disk Drive

**PRIAM V185A 85 MBYTE**

**HARD DISK DRIVE**

Bailey P/N - 1948002\_1

Figure 3-29 shows the required jumper configuration for the PRIAM V185A hard disk drive.

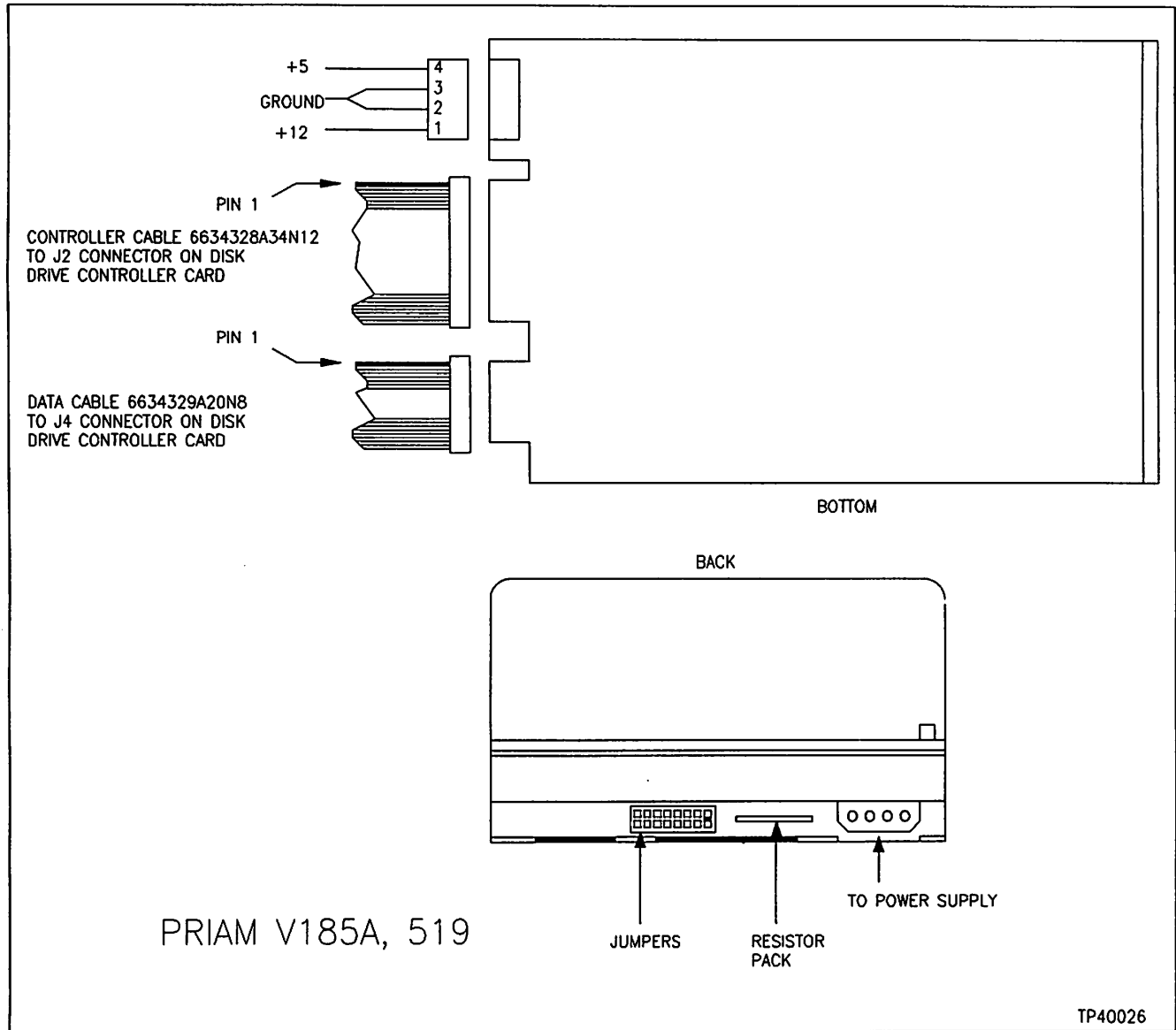

Figure 3-29. PRIAM V185A Hard Disk Drive

## MCS KEYBOARD INTERFACE CARD (MKI)

Bailey P/N - 6636278\_1

The MCS Keyboard Interface Card (MKI) interfaces the keyboard and other operator input

devices to the MCS. Refer to Figure 3-30 and Table 3-12 for wiring connections.

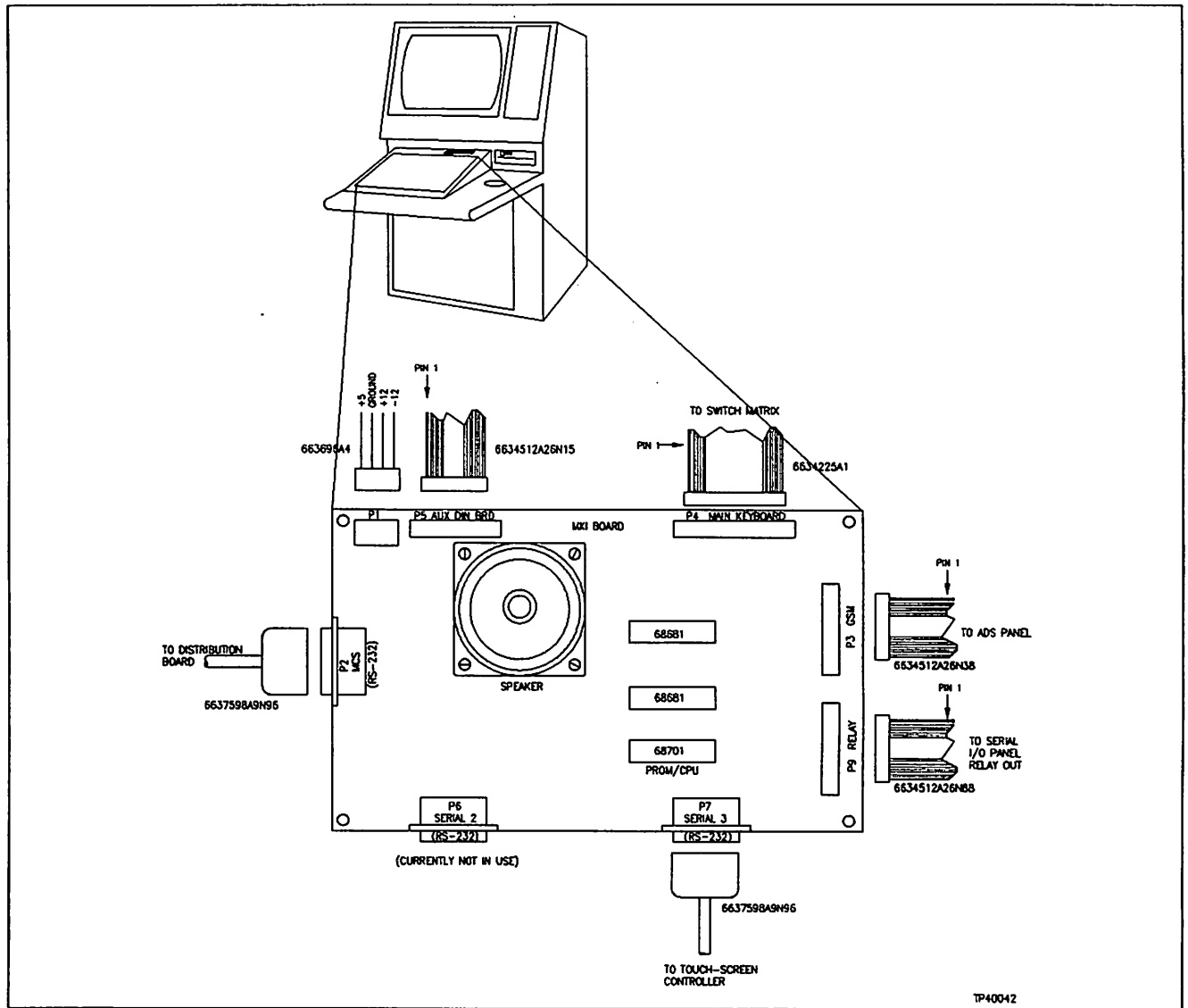

Figure 3-30. Location of Keyboard Controller Card - Main Console

Table 3-12. Connections for Main Keyboard Controller Card

From P1	From P2	From P3	From P4	From P5	From P6	From P7	From P9
To KEYBOARD socket on top of Main Power Supply, use wire assembly no. 6634696_4	To I/O Distribution Board; use wire assembly no. 1948055_22008	To P2 connector on Annunciator Display/ Select Board	To Switch Matrix (located beneath key pad)	To P1 connector auxiliary DIN Board; use wire assembly no. 6634512_26N15	Not used at this time	To RS-232 connector on touch screen controller	To MKI RELAY IN on I/O Distribution Board

**MCS ENHANCED KEYBOARD INTERFACE CARD (EMKI)**  
 Bailey P/N - 6637517\_1

The MCS Enhanced Keyboard Interface Card (EMKI) interfaces the keyboard and other operator input devices to the MCS as does the MKI, and also interfaces an optional Trackball.

(See TRACKBALL in Section 4 of this manual.) Refer to Figure 3-31 and Table 3-13 for wiring connections.

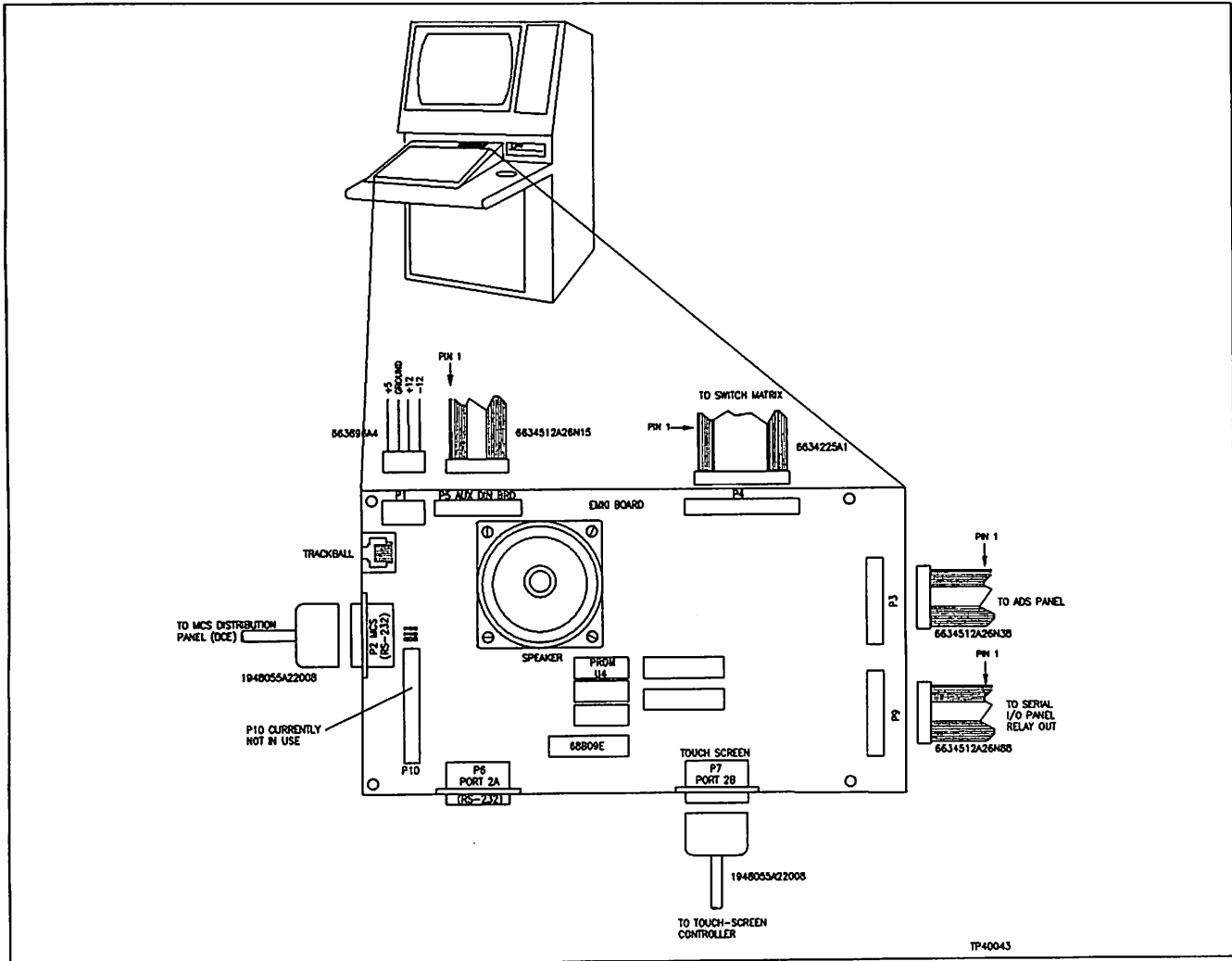

Figure 3-31. EMKI Keyboard Electronics Controller Card

Table 3-13. Connections for EMKI Controller Card

From P1	From P2	From P3	From P4	From P5	From P6	From P7	From P9	From P11
To KEYBOARD socket on top of Main Power Supply, use wire assembly no. 6634696_4	To I/O Distribution Board; use wire assembly no. 1948055_22008	To P2 connector on Annunciator Display/ Select Board	To Switch Matrix (located beneath key pad)	To P1 connector auxiliary DIN Board; use wire assembly no. 6634512_26N15	Not used at this time	To RS-232 connector on touch screen controller	To MKI RELAY IN on I/O Distribution Board	To Trackball Socket



**CONVENIENCE OUTLETS**  
Bailey P/N - 1941268\_3

Convenience outlets (Figure 3-32) are provided for use with 120 V ac 60 Hz user

equipment. Refer to Table 3-14 for wiring connections.

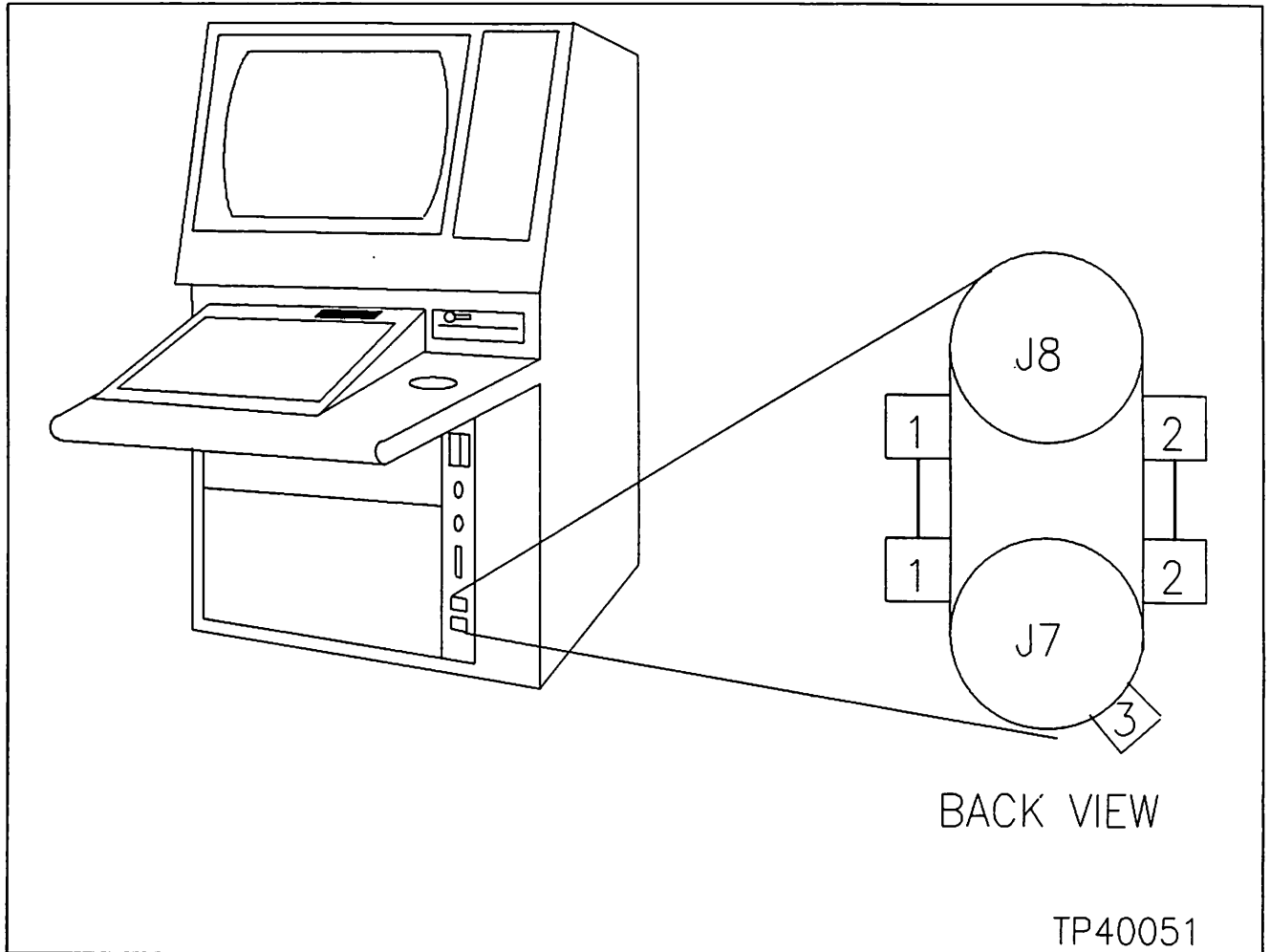

*Figure 3-32. Location of Convenience Outlets J7 and J8*

*Table 3-14. Connections to Convenience Outlets J7 and J8*

From J7 Socket	From J8 Socket	
Lug 3	Lug 1	Lug 2
12 AWG green wire to TB1, lug G	12 AWG black wire to TB2, lug 4	12 AWG white wire to TB2, lug 5

## POWER STATUS LIGHT AND ESD GROUND CONNECTION

Bailey P/N - 1947508\_1

### Power Status Light

When power is applied to the MCS, the power status light (Figure 3-33) turns on. Refer to Table 3-15 for wiring connections.

ESD protective devices such as wrist straps and mats. ESD protective devices should always be used when handling MCS hardware.

### ESD Ground Connection

The ESD (Electrostatic Discharge) Ground Connection is a grounded jack used to connect

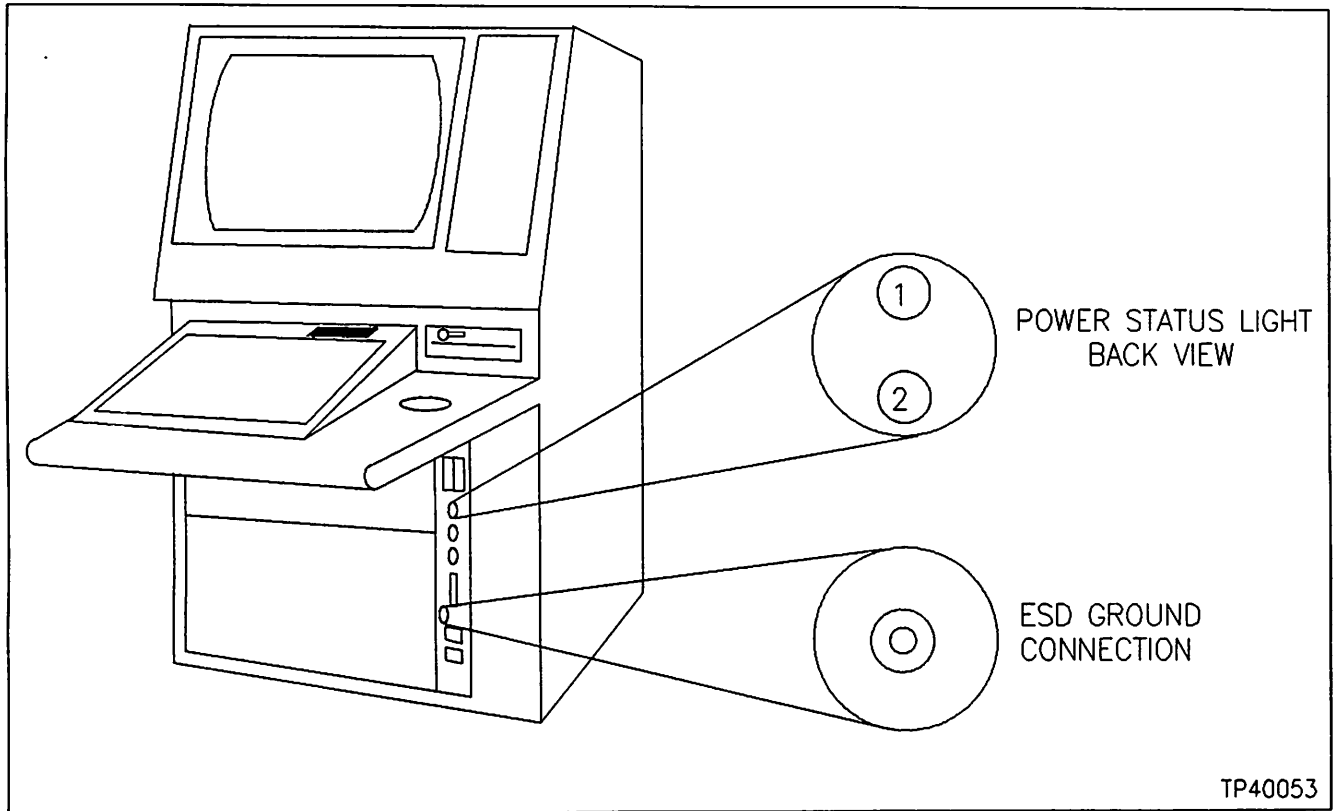

Figure 3-33. Location of Power Status Light and ESD Ground Connection

Table 3-15. Connections to Power Status Light

Lug Number	
1	2
to circuit breaker (CB1), lug 2	to circuit breaker (CB1), lug 4

## POWER SUPPLY - I/O

Bailey P/N - 1948005A

The I/O Power Supply (Figure 3-34) is a 40 watt power supply which provides power to the MCS input and output devices. Table 3-16 gives the necessary wiring connections from the two terminal blocks of the I/O Power

Supply (internally and externally mounted). The AC power cord plugs into socket J4 on the AC distribution board.

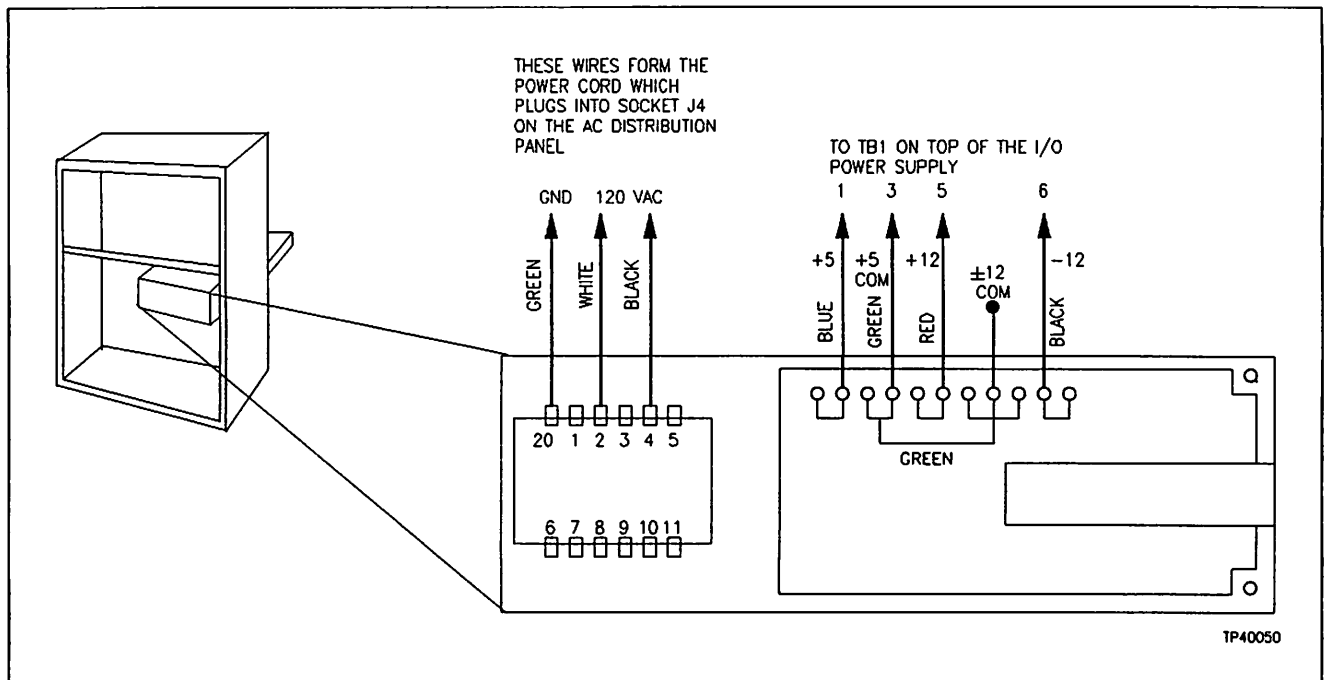

Figure 3-34. Location of I/O Power Supply

Table 3-16. Connections to I/O Power Supply\*

From TB1 Terminal Number (at top of I/O Power supply)			
7	8	10	12
To -12 V terminal on I/O power supply with 12 AWG black wire	To +12 V terminal on I/O power supply with 12 AWG red wire	To +5 V COM terminal on I/O power supply with 12 AWG green wire	To +5 V terminal on I/O power supply with 12 AWG blue wire
* You must also connect a length of 12 AWG green wire between the +5 V COM and ±12 V COM terminals on the I/O power supply.			

**POWER SUPPLY - I/O**  
Bailey P/N - 1948005A

Sockets (Figure 3-35) are provided on top of the I/O Power Supply. Note that not all of the voltages shown are from the power supply, but also those of system signals.

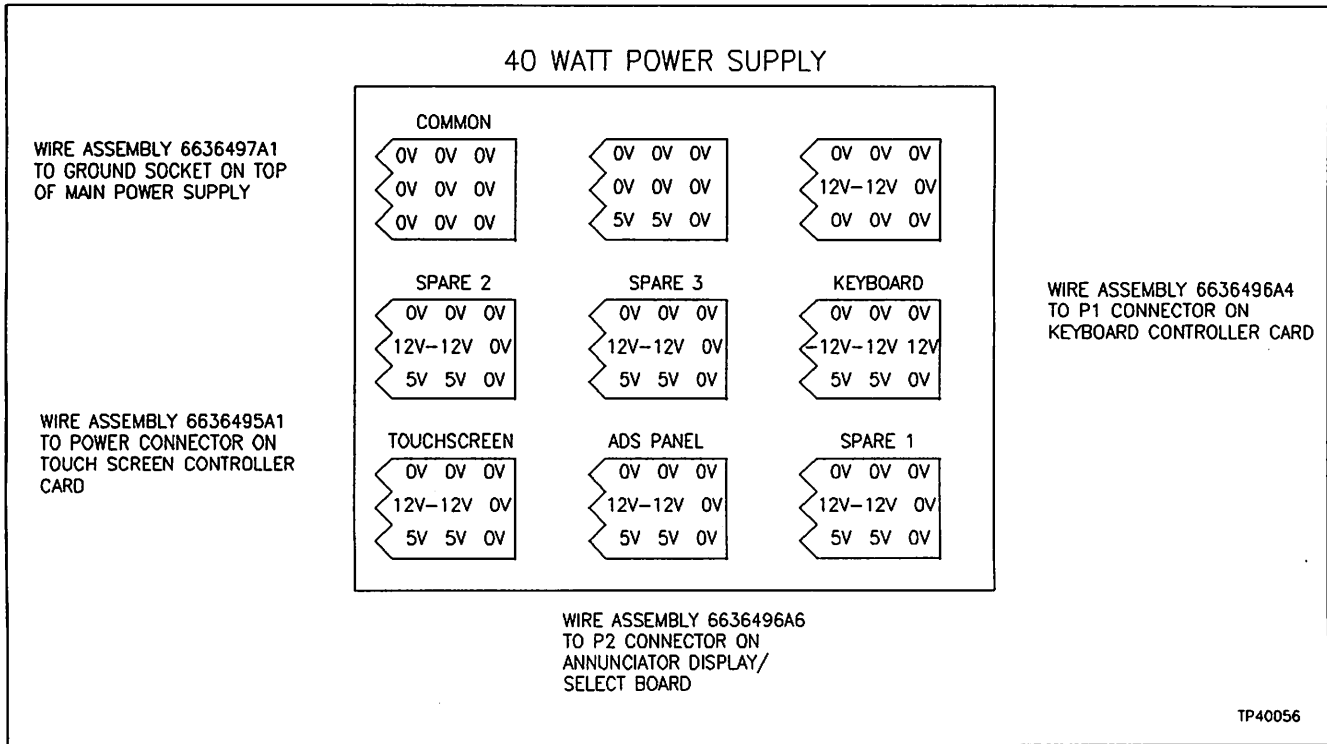

**Figure 3-35. I/O Power Supply (Top View)**

## POWER SUPPLY - MAIN

Bailey P/N - 1948003A

The Main Power Supply (Figure 3-36) is a 750 watt power supply which provides power to all MCS Multibus cards and disk drives. Table

3-17 gives the necessary wiring connections for TB1, found at the top-rear of the supply.

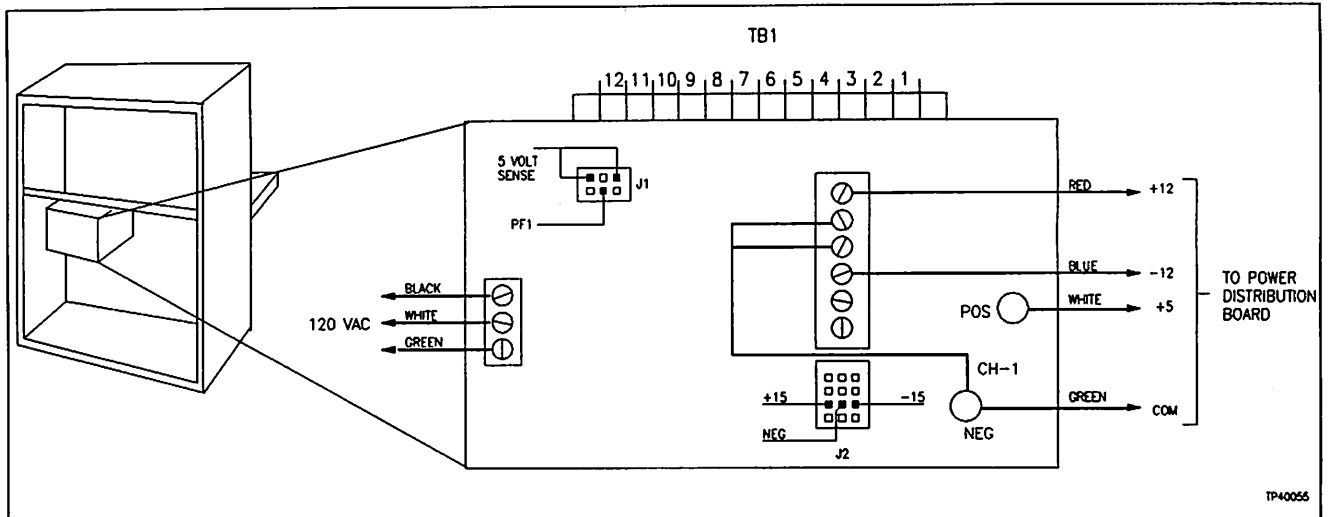

Figure 3-36. Location of Main Power Supply

Table 3-17. Connections on TB1 of Main Power Supply

1	2	3	4	5	6
To J1 plug with green wire from assembly number 6636537_1	To J1 plug with white wire from assembly number 6636537_1	To J1 plug with red wire from assembly number 6636537_1	To J1 plug with black wire from assembly number 6636537_1	To J2 plug with orange wire from assembly number 6636538_1	To J2 plug with yellow wire from assembly number 6636538_1
7	8	9	10	11	12
Use wire assembly 6636491_1					
To CH3 terminal with 12 AWG blue wire	To E1 tab (+24 V dc) on NTCL01 with 14 AWG red wire	To tab 3 on MMU backplane (COM) with green wire	To tab 3 on MMU backplane (COM) with green wire	To tab 1 on MMU backplane (+5) with white wire	To tab 1 on MMU backplane (+5) with white wire
To E2 tab (COM) on NTCL01 with 14 AWG blue wire	To CH2+ with 12 AWG red wire	To TB1 terminal number 10 with 12 AWG green wire	To TB1 terminal number 9 with 12 AWG green wire  To CH1 NEG post terminal with 12 AWG green wire	To TB1 terminal number 12 with 12 AWG white wire	To TB1 terminal number 11 with 12 AWG white wire  To CH1 POS post terminal with 12 AWG white wire

# POWER SUPPLY - MAIN

Bailey P/N - 1948003A

Table 3-18 gives the necessary wiring connections for all terminals at the rear of the supply.

Table 3-18. Connections on rear of Main Power Supply

From J1	From J2	From CH1 POS	From CH1 NEG	From CH2 POS	From CH2 NEG	From CH3 POS	From CH3 NEG	From CH4 POS	From CH4 NEG
Use wire assembly 6636537_1, connect:	Use wire assembly 6636538_1 connect:	Use wire assembly 6636494_1, connect:	Use wire assembly 6636494_1, connect:	To TB1 terminal number 8; use 12 AWG red wire	To CH3 POS terminal; use 12 AWG green wire  To CH1 NEG post terminal; use 12 AWG green wire	To CH2 NEG terminal; use 12 AWG green wire	To TB1 terminal number 7; use 12 AWG blue wire	Not used	Not used
Green wire to TB1 terminal number 1	Orange wire to TB1 terminal number 5	Two white wires to TB3, tab position 1	One green wire to TB6, tab position 1						
White wire to TB1 terminal number 2	Yellow wire to TB1 terminal number 6	Two white wires to TB3, tab position 2	One green wire to TB6, tab position 2						
Red wire to TB1 terminal number 3	Green wire to CH1 NEG post terminal	One white wire to TB4, tab position 1	Two green wires to TB5, tab position 1						
Black wire to TB1 terminal number 4		One white wire to TB4, tab position 2	Two green wires to TB5, tab position 2						
		To TB1 terminal number 12; use 12 AWG white wire	To J2 connector; use green wire from assembly 6636538_1  To CH2 NEG terminal; use 12 AWG green wire  To TB1 terminal 10; use 12 AWG green wire  To CHASSIS GROUND on AC Distribution Board; use green wire from assembly 6636501_1						

**POWER SUPPLY - MAIN**  
Bailey P/N - 1948003A

Sockets (Figure 3-37) are provided on top of the Main Power Supply. Note that not all the voltages shown are from the power supply, but also those of system signals.

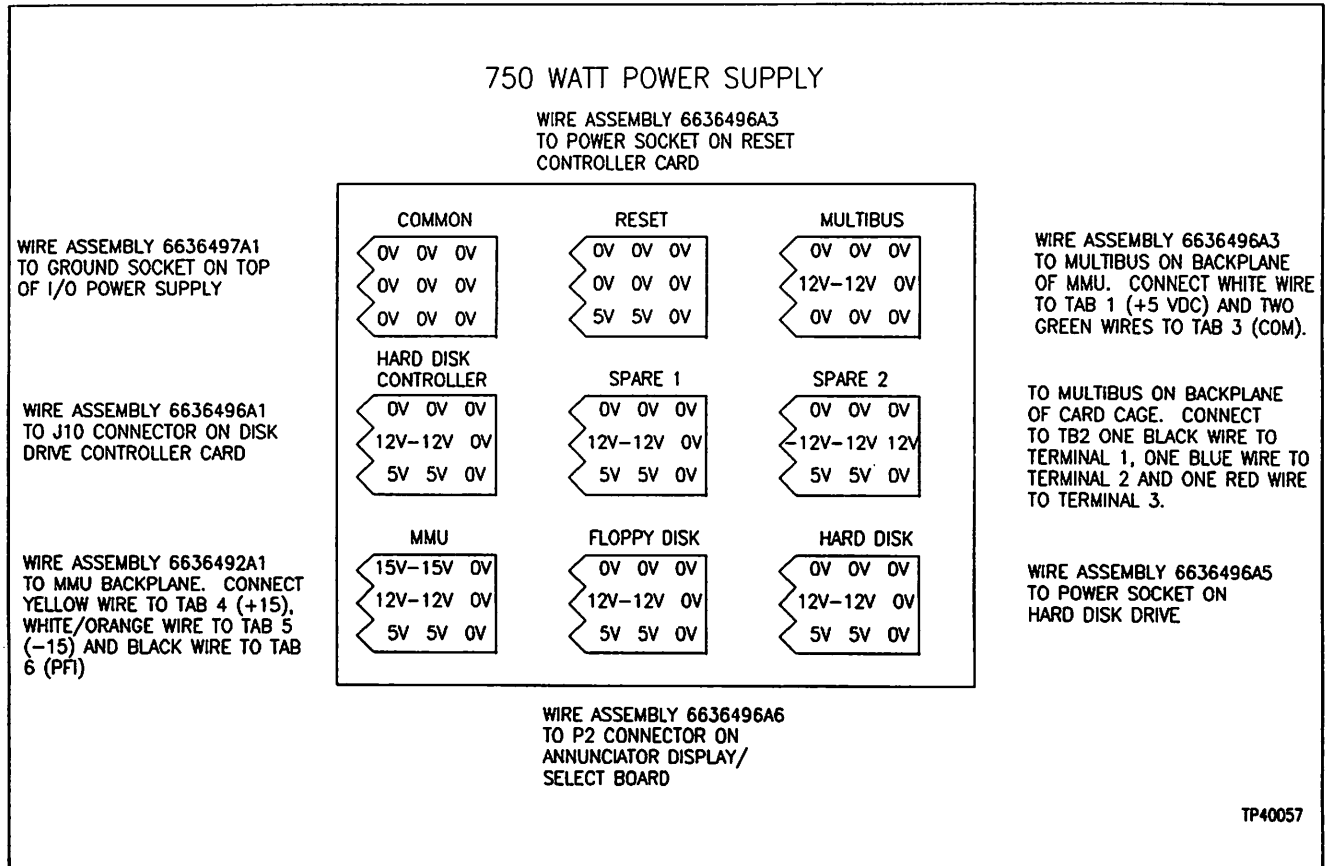

**Figure 3-37. Main Power Supply (Top View)**

# RESET BUTTON and CONTROLLER BOARD

Bailey P/N - 6636410

The MCS is reset to initial power-up conditions by pressing the reset button. The reset controller board ensures a correctly timed

reset pulse. Refer to Figure 3-38 for wiring connections.

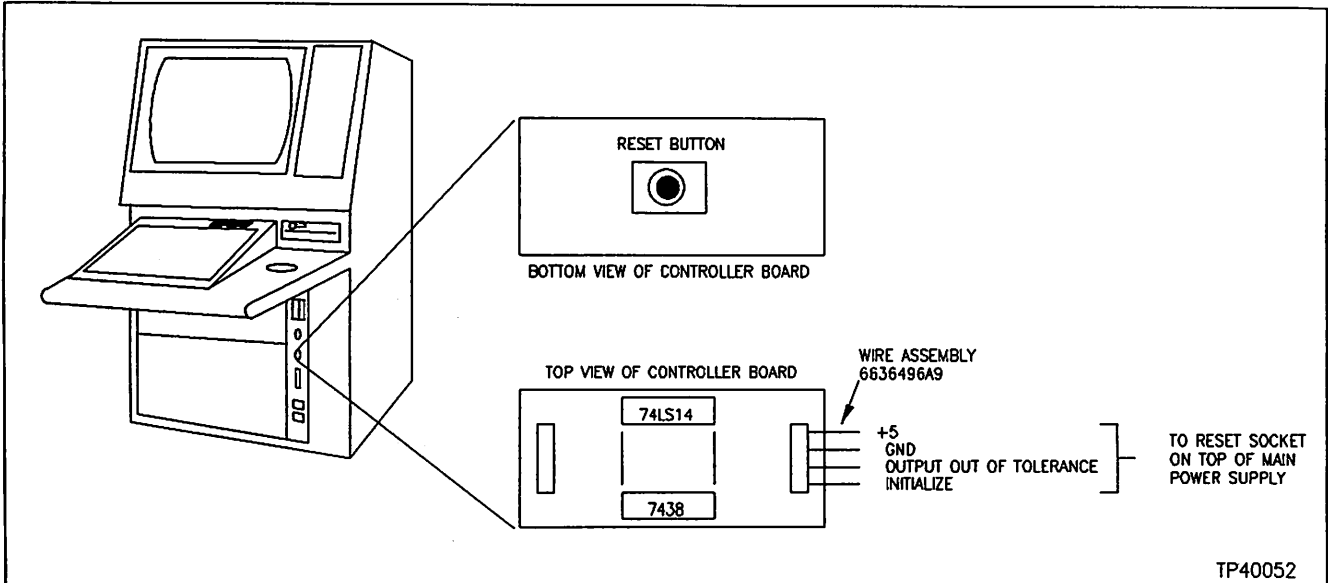

Figure 3-38. Location of Reset Button and Controller Board



## TERMINATION UNIT - COMMUNICATION LOOP

Bailey P/N - NTCL01

The Termination Unit (TU) interfaces the MCS to the Communication Loop. A cable (NKLM01/02/03/04) connects the TU and the Loop Interface Module (NLIM02). One end of the cable plugs into the P1 socket on the TU;

the other ends snaps into place at the back of the MMU (standard position is slot 11).

NOTE: The jumpers on the NTCL01 are user defined. Refer to Bailey Product Instruction E93-911 for more information.

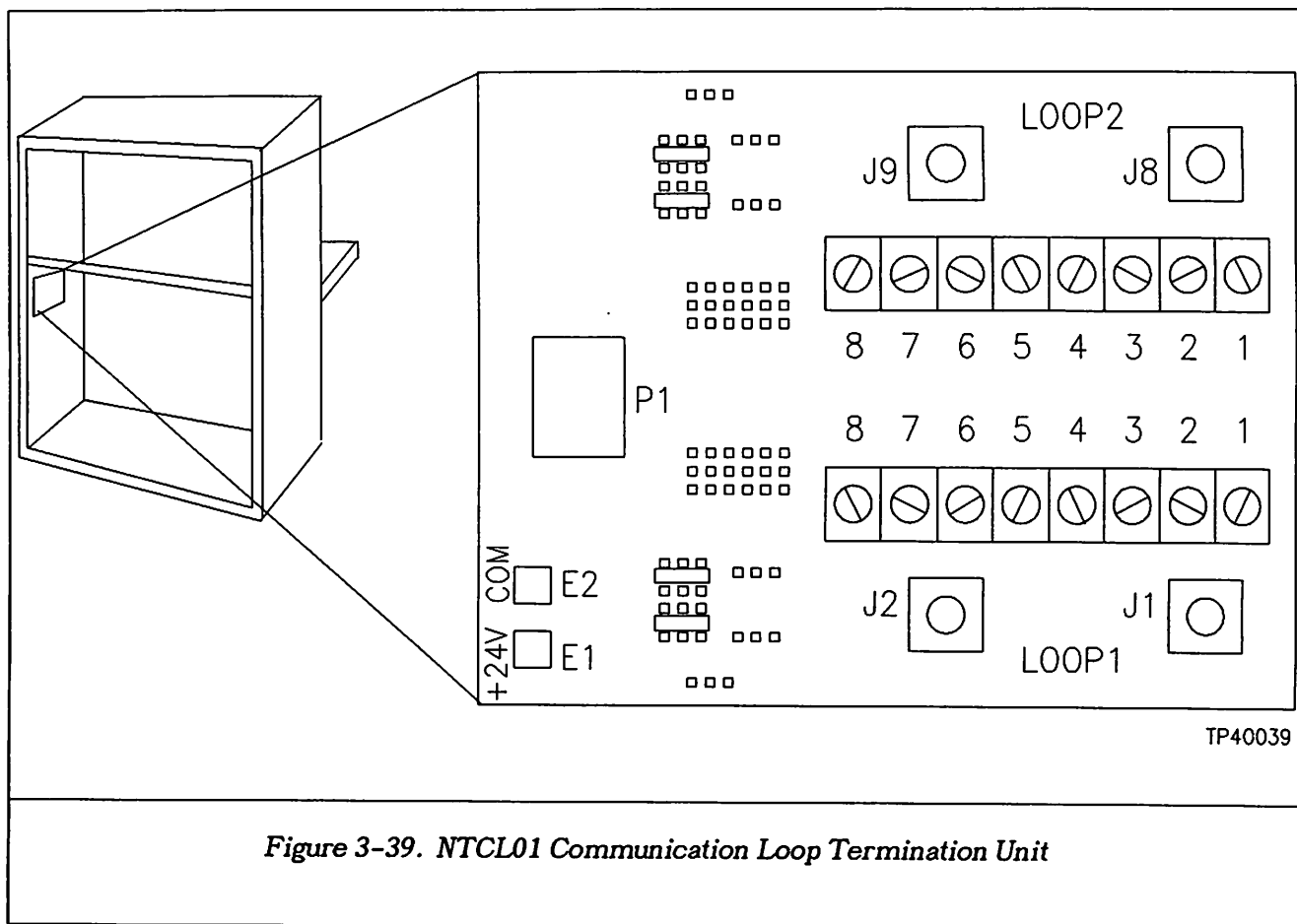

Figure 3-39. NTCL01 Communication Loop Termination Unit



---

---

## SECTION 4 – MCS OPTIONS

Section 3 provides detailed information on the hardware within the standard base MCS. This section details optional hardware your MCS may contain, and the installation procedures necessary to upgrade your current system. Available hardware options are:

- Annunciator Display/Select Panel (up to four panels per keyboard)
- Application Processor
- Color Graphics Card(s) (three may be added, giving a total of four)
- Color Monitor(s) (one per Color Graphics Card)
- Color Video Copier System (NPRT04)
- Engineering Keyboard(s) (a maximum of 4, 1 per MKI keyboard)
- Nine Track Reel-to-Reel Tape Backup (NMTP01/02)
- Printer(s) (a maximum of 4; one per main console)
- Redundancy Transfer Switch (NMRT01)
- Remote Electronics Driver Cabinet (NMED01)
- SCSI Nine Track Reel-to-Reel Tape Backup Adapter
- Streaming Tape Drive (NSTP01)
- Superloop Computer Interface Unit (NCIU04)
- Touch Screen (one per color monitor and keyboard electronics card)
- Trackball

The I/O Distribution Board contains connection points for additional MCS options. The connector locations are clearly labeled. Adding new hardware requires making the proper cable connection to this distribution board and making any required jumper and/or dipswitch settings. Also of importance are the two power supplies. The covers on these supplies contain clearly labeled sockets which receive cables from system hardware. Specific installation procedures for individual components are given separately.

## ANNUNCIATOR/DISPLAY SELECT BOARD (ADS)

Bailey P/N - 6636448\_1

The Annunciator/Display Select board (ADS) provides a panel of 64 lamps and push buttons. Each lamp and push button can be assigned to an MCS display. When a tag on a display goes into an alarm condition, the assigned ADS lamp turns on. Pressing the assigned push button causes the assigned display to be printed to the screen.

An MCS can drive a total of four monitor/keyboard optional terminals (refer to **COLOR MONITOR(S)** in this section of this manual). Four ADS panels may be installed per each monitor/keyboard combination, for a total of 16. Refer to Figure 4-1 for dipswitch configuration. Refer to Table 4-1 for wiring connections to the ADS Panel.

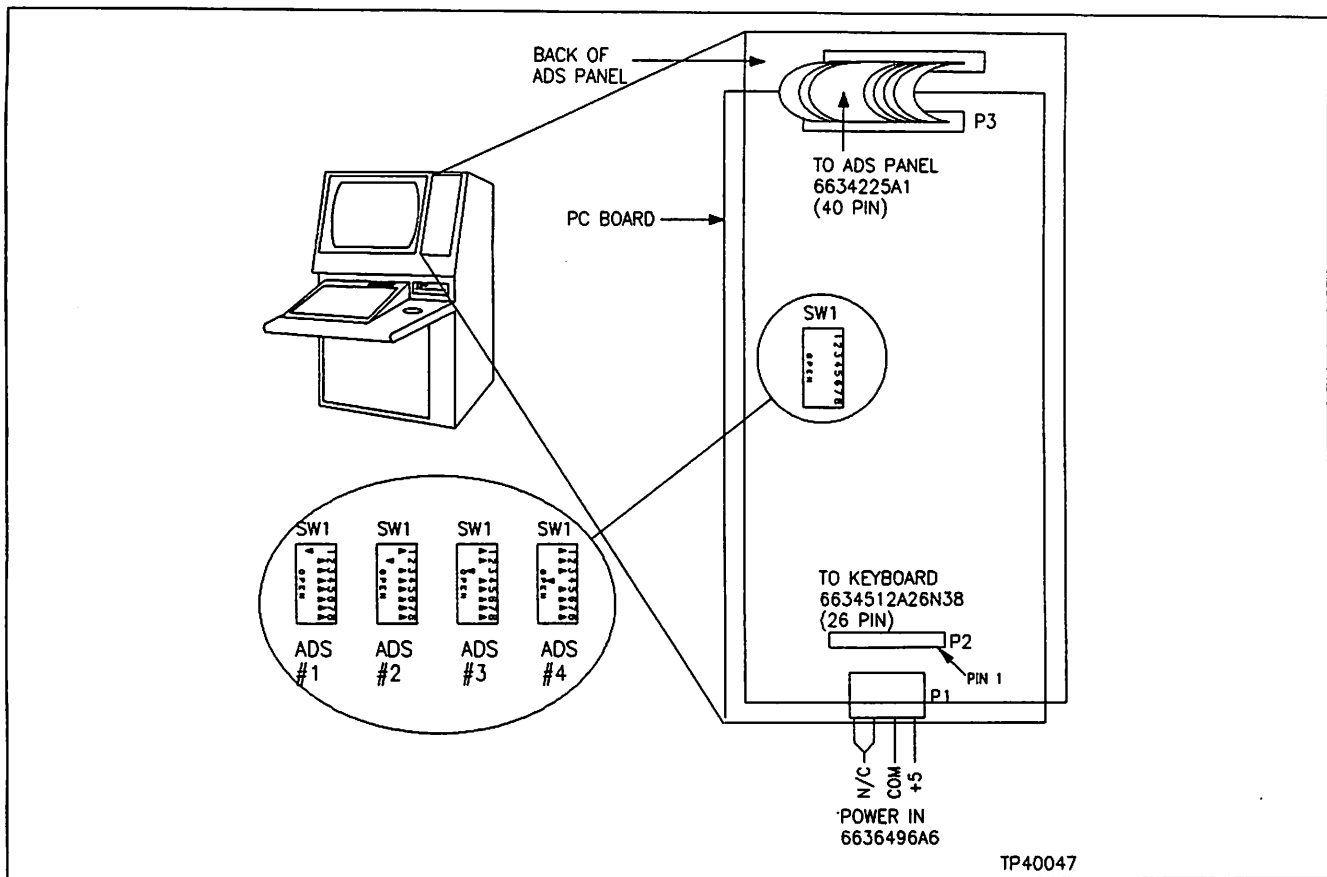

Figure 4-1. Location of Annunciator/Display Select Board

Table 4-1. Connections to Annunciator/Display Select Board

From P1	From P2	From P3
To GROUP SELECT socket on top of I/O Power Supply; use wire assembly number 6636496_6	To P3 connector on Keyboard Controller Card; use cable number 6634512_26N38*	To P3 connector on Annunciator Display/Select Panel; use cable number 6634225_1*
*26 Pin Ribbon Cables, maximum length - 15 feet (4.5 m)		

## APPLICATION PROCESSOR (AP)

Bailey P/N - 6637033\_1 - CPU Card - Slot 23  
6637447\_1 - Memory Card - Slot 22

The Application Processor provides custom programming. Supported languages are C, Fortran, and 68000 assembly. Refer to Bailey Product Instruction E93-901-25 for further information. A maximum of two application processors can be added. The jumper settings and locations of these processor cards are shown in Figure 4-2.

The Application Processor has a separate reset button located in the front left panel just below the MCS reset on the NMCS02, and to the left of the floppy disk drive just below the MCS reset button on the NMED01.

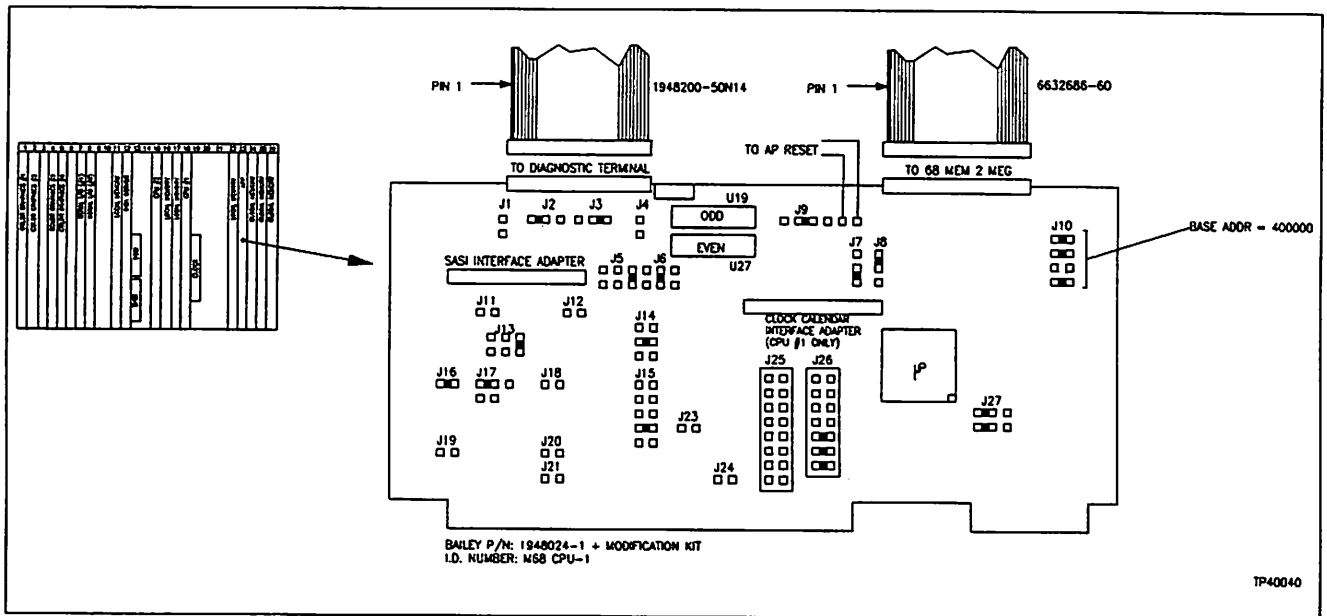

Figure 4-2. Application Processor

## APPLICATION PROCESSOR (AP)

The standard MCS CPU card is transformed into an Application Processor with the Bailey Upgrade Kit (P/N 1948203\_1) (Table 4-2). The kit contains 7 jumpers, 5 PALs, and a set of conversion instructions.

### Conversion Procedure:

1. Cut wire wrap jumper leads and unwrap using needle nose pliers.
2. Install jumpers from kit on locations as specified in Figure 4-2.
3. Remove the five PALs listed for a standard CPU Card.
4. Install the five PALs from the kit in the specified sockets for an Application Processor.
5. Remove EPROMs in locations U27 and U19. Replace with P/N 1900108\_\_\_\_ as listed.
6. Cross out silk-screened card designation and re-label as M68 CPU-1 with an indelible marker.

*Table 4-2. Transforming MCS CPU Card into an AP Card*

	Socket	PAL Part Number	Socket	Bailey Part Number	J27
Application Processor	U44	66411	U27	1900108_1_	o-o o
	U20	66408	U19	1900108_2_	o-o o
	U57	66414			
	U63	66415			
	U74	66421			
Standard CPU Card Bailey P/N 1948024_1	U44	66448	U27	1900105_1_	o o-o
	U20	66447	U19	1900105_2_	o o-o
	U57	66490			
	U63	66450			
	U74	66452			

# COLOR GRAPHICS CARD(S)

Bailey P/N - 1948025\_1

Color Graphics cards drive MCS monitors. Each additional MCS monitor requires a Color Graphics Card. Each card requires configuration by setting jumpers. Refer to Figure 4-3 for

card locations and jumper settings. Refer to COLOR MONITOR(S) of this section for monitor wiring connections.

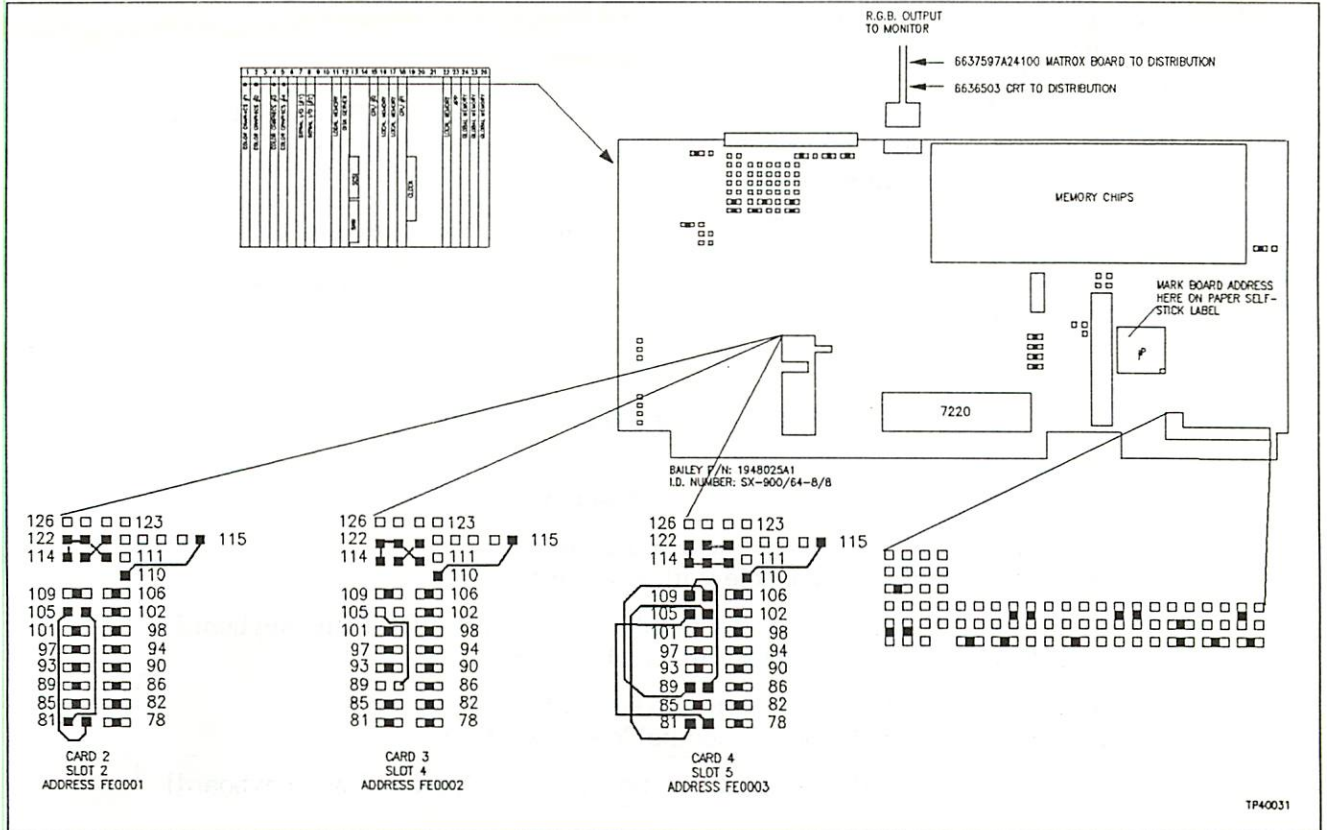

Figure 4-3. Location and Configuration of Color Graphics Controller Cards

## COLOR MONITOR(S)

Adding additional color monitors is model dependent. Refer to Table 4-3 for a list of available color monitor options.

A second color monitor requires adding a second color graphics card. Refer to COLOR GRAPHICS CARD(S) in this section for card cage location and configuration information. Slide the card into place and secure the two front latches. Plug the RGB inputs line into the socket on the front of the card. Connect the separate Red, Green, and Blue lines to the appropriate points on the back of the I/O distribution board. Next, connect the cable assembly from the front of the I/O distribution board, to the corresponding receptacles on the back of

the color monitor. Plug the monitor power line into the proper socket on the AC distribution board.

The procedure for additional monitors is similar to that for adding a second one. Each monitor requires a separate color graphics card.

NOTE: If remote CRTs are being installed, insure they are powered using the same polarized power and ground as the MCS to prevent ground loops. Failure to do so may cause display distortion. If ground loops are still suspected, use of optically isolated modems will eliminate the problem.

Table 4-3. Color Monitor Options

Bailey P/N	Description
NCRT01	19" CRT table top with keyboard
NCRT02	19" CRT console with keyboard
NCRT03	Stand-up (environmental) unit with 19" CRT and keyboard
NCRT04	Two 19" CRTs with one keyboard
NCRT05	19" CRT table top - no keyboard
NCRT06	19" CRT panel mountable - no keyboard
NCRT09	19" CRT in NUCC01 - no keyboard (NCRT02 w/o keyboard)



---

---

## COLOR VIDEO COPIER SYSTEM

Bailey P/N - NPRT04

The NPRT04 is used to make a color hard copy of an MCS screen. This is done by pressing the copy key on the MCS keyboard. Related products for the NPRT04 are:

Color Copier	1948439_1
Video Processor	1948440_1
Centronics Cable	6634330N10
MCS Cable	6637356_1-25
Spare Ink Roll	1948465_1
Spare Paper Roll	1948464_1
RGB Cable Assembly	NKMC01-25
BNC Tee Adapter	1945080_4

### Operation Summary

There are two main parts to the Color Video Copier System. These are the video processor and the color copier.

The function of the video processor is to capture all needed information from an MCS

screen in a matter of seconds. The video processor then sends this information as it is needed to the color copier. This frees up the MCS screen to enable an operator to continue with his work while the color copy is actually being produced. The video processor has internal memory to store multiple screens. When multiple screens are stored by the video processor, they are printed out one after another in the order in which they were stored.

The color copier is the device that makes the actual color copy. It takes approximately 45 to 60 seconds to make a color copy of an MCS screen. The copier makes three passes over the paper, placing the yellow, red, and blue colors on the paper separately. When the copy is done, the copier aligns itself to make the next copy, at which time the color copy just produced may be torn off at the perforation.

## COLOR VIDEO COPIER SYSTEM

### Installation

After unpacking both the copier and video processor, place them side by side. First, configure the DIP switches on the rear of the video processor (Figure 4-4). The following information may be useful when configuring the DIP switches:

Termination for the red, green, and blue video signals should be 75 ohm (S1-1 through S1-6 all down).

The signal levels for the video inputs are one volt nominal (S2-1 and S2-2 down).

Switch positions S2-3 and S2-4 are related to the sync. These switch positions should be set to reflect that our sync is on the green video input (S2-3 and S2-4 both down).

Switch 3 is related to the attenuation of our video signals. The signal levels for the video inputs are one volt nominal, thus we want these switch positions to be the high gain settings (S3-1 through S3-6 all down).

Connections of the red, green, and blue video signals from the MCS monitor to the video processor is done with the NKMC01 RGB cable assembly.

If a Hitachi monitor is being used, it is necessary to use BNC tee adapters to make the connections from the graphics board to the monitor and from the monitor to the video processor. To do this, connect the BNC tee adapters (P/N 1945080\_1) to the red, green, and blue connectors on the back of the monitor. Make sure the termination beside each of these connectors is set to the high impedance setting (down). Connect the RGB output from the graphics board to one side of the BNC tee adapters. Connect one end of the NKMC01 RGB cable assembly to the other side of the BNC tee adapters. Connect the other end of the NKMC01 cable assembly to the red, green and blue inputs on the back of the video processor (Figure 4-4).

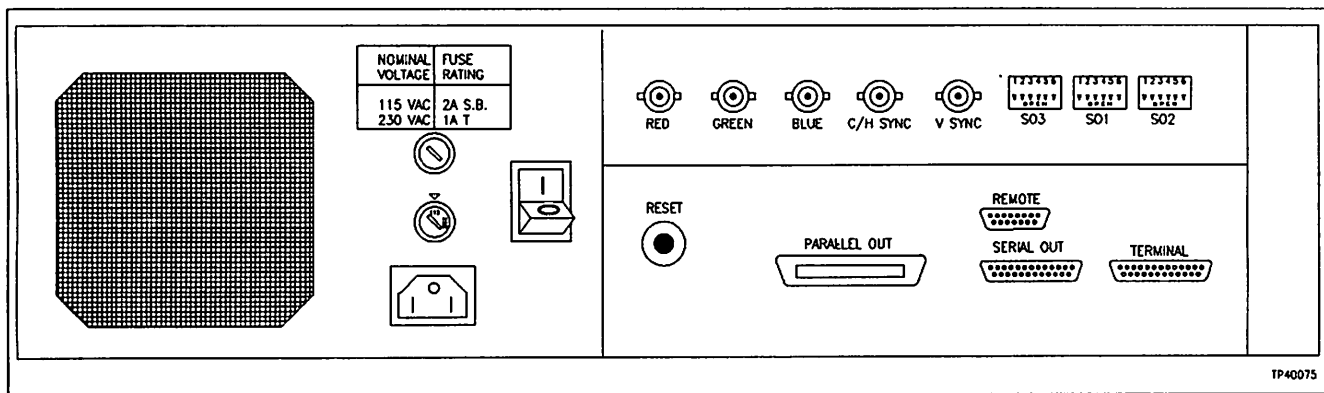

Figure 4-4. Back View of the Color Video Processor

---

---

## COLOR VIDEO COPIER SYSTEM

If a Mitsubishi monitor is being used, connect one end of the NKMC01 RGB cable assembly to the red, green, and blue loop-through connector on the back of the monitor. Make sure the termination switch beside each of these connectors is set to the 75 ohm position (up). Connect the other end of the NKMC01 cable assembly to the red, green, and blue inputs on the back of the video processor (Figure 4-4).

Next, connect the video processor to the copier with the Centronics Parallel cable (P/N 6634330\_30N25). Connect one of the Centronics cable to the signal input on the back of the copier (Figure 4-4). Connect the other end of the Centronics cable to the parallel port connector on the back of the video processor (Figure 4-4).

Connect the MCS video processor cable from the remote port of the video processor to the MCS I/O Distribution Board relay contact that will be dedicated to handle the capture initiation process. Which relay contact will handle this function is user configurable. This relay contact will be controlled by the copy key on the MCS keyboard. When the copy key is depressed, the MCS screen is frozen for approximately five seconds. As soon as the

screen has been frozen, the relay contact controlling the capture initiation is closed for a minimum of 10 microseconds. This pull the capture line on the video processor low. A low on this line tells the video processor to initiate a screen capture. The video processor then obtains all needed information off the red, green, and blue lines of the MCS screen to make a color copy. This takes approximately three seconds. After all needed information is obtained from the MCS screen, it is no longer necessary to keep the screen frozen. Thus, the screen is freed and the operator may continue with his work while the color copy is actually being produced.

Connect the DB9 side of the MCS video processor cable to the remote connector on the back of the video processor (Figure 4-4). Connect the two lugs on the other end of the cable to the relay contact to perform this function.

Connect the black wire to the terminal labeled C for the relay contact. Connect the white wire to the terminal labeled NO for the relay contact (Figure 4-4).

## ENGINEERING KEYBOARD(S)

Bailey P/N - NAKB01

Each MCS console supports an additional engineering QWERTY keyboard. The keyboard plugs into a five pin DIN located above the membrane keyboard on the main MCS console (Figure 4-5).

**NOTE:** The recommended procedure requires removing power from the MCS before plugging in the engineering keyboard. Failure to do so may result in faulty operation due to an improper initial state.

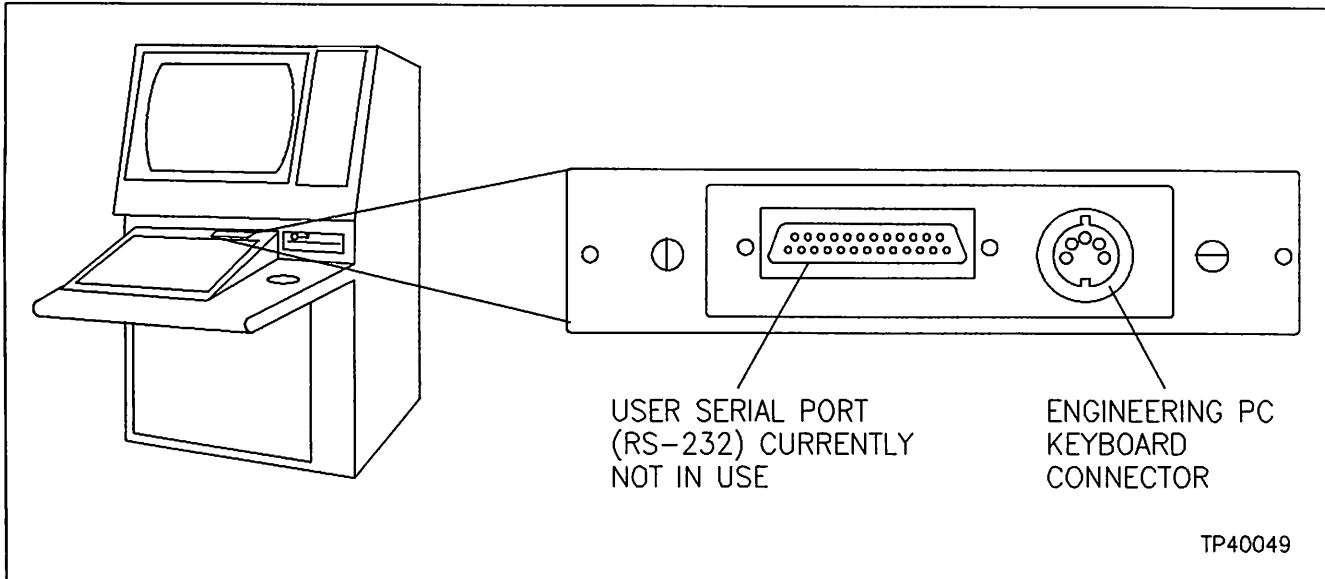

Figure 4-5. Engineering Keyboard Connector

---

---

## NINE TRACK REEL-TO-REEL TAPE TRANSPORT

Bailey P/N - NMTP01 Mounts in NMED01 systems.  
NMTP02 Mounts in NCWS01, NCPS01, or NCRT02 for NMCS02 systems.

The MTP is a nine track 1/2 inch reel-to-reel tape drive. Parts contained in the base MTP drive are:

1	Print of DWG _6637805
1	194776_23001 - 3 Amp Slow Blow Fuse
1	1947950_5 - Power Cord
1	1948468_1 - SCSI Interface
1	1948032_31200 - Ribbon Cable Assy.
1	1948380_1 - Magnetic Tape Drive

The NMTP01 mounts in the NMED01. It contains the components of the base MTP drive and the parts:

12	NTLAC19000 - Lockwasher
12	NMPCC16002 - Nut
12	NANAU16008 - Screw
4	6637702_1 - Mounting Plate
1	6637701_1 - Support Rod
1	6637698_1 - Vent Panel
2	6637703_1 - Support Panel
1	6637805_1 - Base Magnetic Tape Drive

The NMTP02 mounts in the NCRT02. It allows mounting in the NCWS01, NCPS01, NUCC01, and the NCRT02. It contains the components of the base MTP drive and the parts:

1	Print of DWG C258449, this kit
1	Print of DWG C6637727, base
1	Print of DWG C6637726, shelf
1	Print of DWG B6637724, support rod
8	NDPAC16006 - Tap Screw
1	6637730_1 - Mounting Rack
2	6637728_1 - Mounting Tab
1	6637723_2 - Mounting Rail, rear
1	6637723_1 - Mounting Rail, rear
1	6637725_1 - Rack Mounting Rail, front
1	6637725_2 - Rack Mounting Rail, front
1	6637805_1 - Base Magnetic Tape Drive

### Unpacking

On tape transport, open the hinged tape guide lid; remove the packing material (Figure 4-6). Unscrew retainers at left and right front edges and lift the hinged transport mechanism, exposing circuit boards (Figure 4-7). Separate card frames and remove packing material from the boards. Unpack CSC-100 SCSI adapter kit.

# NINE TRACK REEL-TO-REEL TAPE TRANSPORT

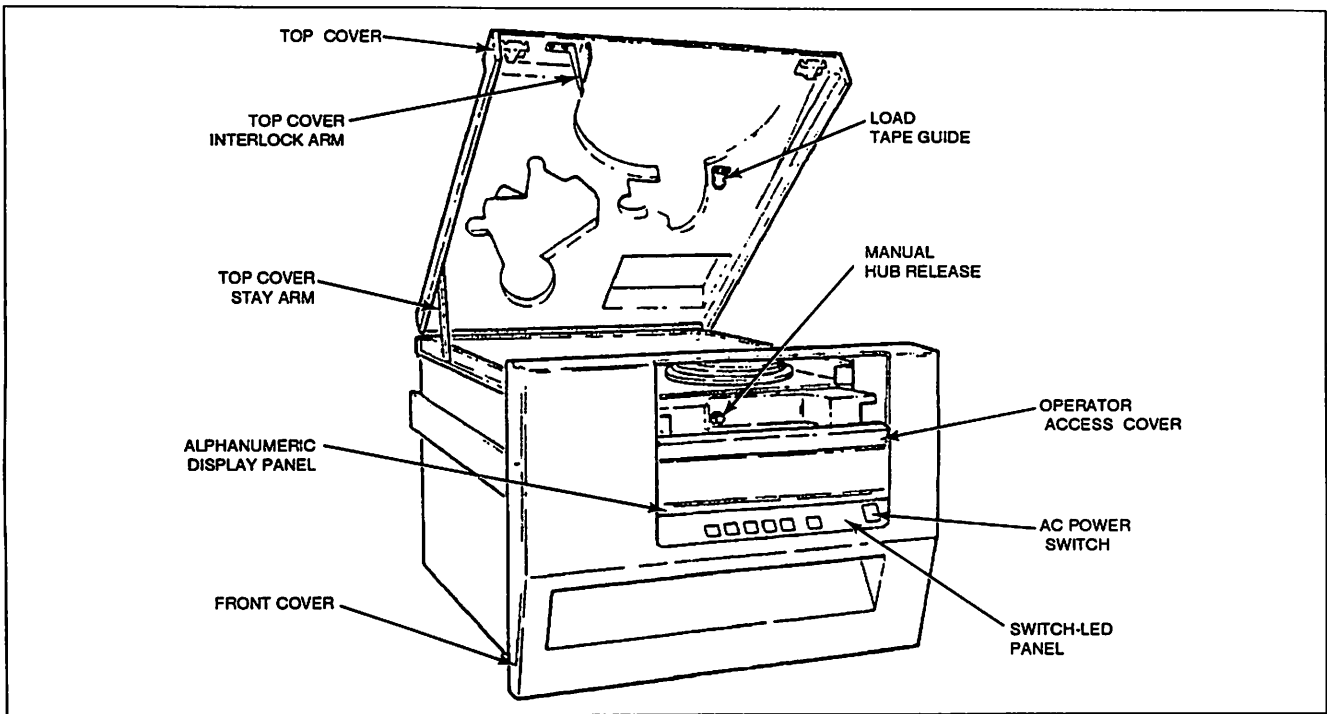

Figure 4-6. Reel-to-Reel Tape Drive Unit

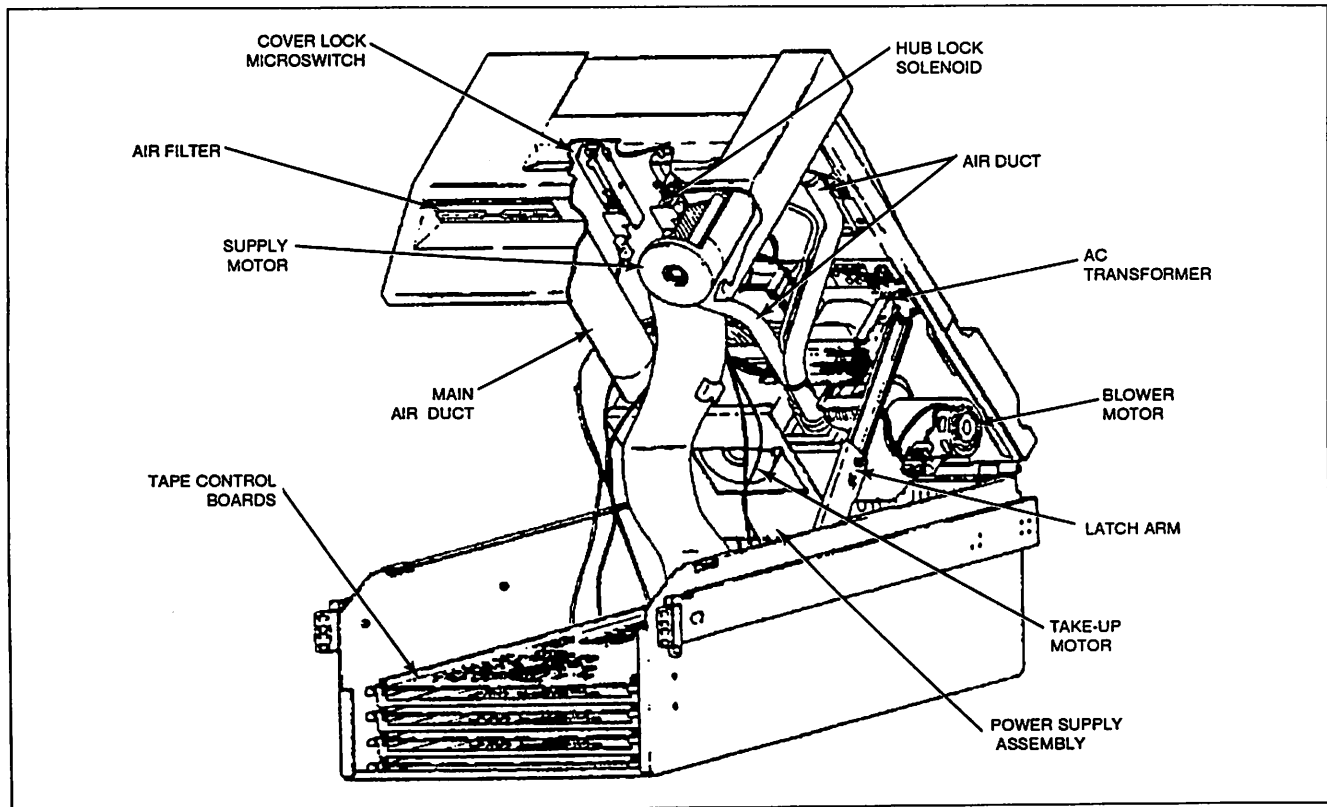

Figure 4-7. Transport Tape Mechanism

---

## NINE TRACK REEL-TO-REEL TAPE TRANSPORT

### Preparation, Transport, M990

1. At right rear of transport, locate two pin white nylon cable jack marked J9, and pass it out the back-of-case opening the shape of that connector.

2. In the event that no J9 connector is in the wiring harness, locate the provisioned J9 jack with one foot white and black leads terminating in fasten lugs. Clip lugs, strip and splice white and black leads to similarly colored wires in the harness. Insulate with electrical tape. (Feed connector through rear of transport.)

3. Turn power on.

4. Check for +48 V at white lead with respect to black (-). Correct as required.

5a. **NMCS02 Applications:** Locate two rack slides and position inner slide on each side with mounting ears facing outward at front. Extend slides and mount using three furnished machine screws, heads inserted through slides then through corresponding three holes in each side. Retain using six locknuts inside case.

5b. **NMED01 Applications:** To install the nine track transport in NMED01 driver cabinet, the hardware provided with the NMTP01 is used to mount rails underneath the transport, rather than on the sides, as with the NMTP02. Locate the two support panels and orient with tabs pointing inward on each side. Open

transport, unbolt rack slide hinges, and transfer them to corresponding locations on the left and right support panels. Mount support panels to transport sides, through the holes where hinges are mounted.

6. Detach and mount rack ear section of each slide to front and rear cabinet rack rails. Mount above shelf of NMED01 cabinet or using bottom rail pattern of NCRT02 work surface enclosure.

**NOTE:** When manual tape mounting or service is required, the transport must be hinged up in operation.

7. Lift transport into rail engagement in cabinet (requires a minimum of two people).

### Preparation, SCSI Interface Unit, CSC-100

1. Place unit upright, and remove two screws near tapered edge. Lift open hinged lid.

2. Locate +48V power cable labeled 962031 and insert connector P1 in circuit board location J4, engaging cable plug kerf in chassis jack clip. Re-Seat ROMs in sockets.

3. Route loose P2 connector through large cutout. Close the box.

4. Locate two 6 inch braided straps. Slip a box retaining screw through each straps lug, and re-fasten box.

## NINE TRACK REEL-TO-REEL TAPE TRANSPORT

### External Setup

1. Locate two 50 pin ribbon jumpers marked 961991. Orient the pin header P2 connector of each so striped edge is at location silk-screened 1/2, then insert one each into board locations J1 and J2.

2. Orient tapered edge of CSC-100 to view LED's at left and DIP switches to their right (Figure 4-8). Set ID switches one through four open (up), and switch five of right most switch open.

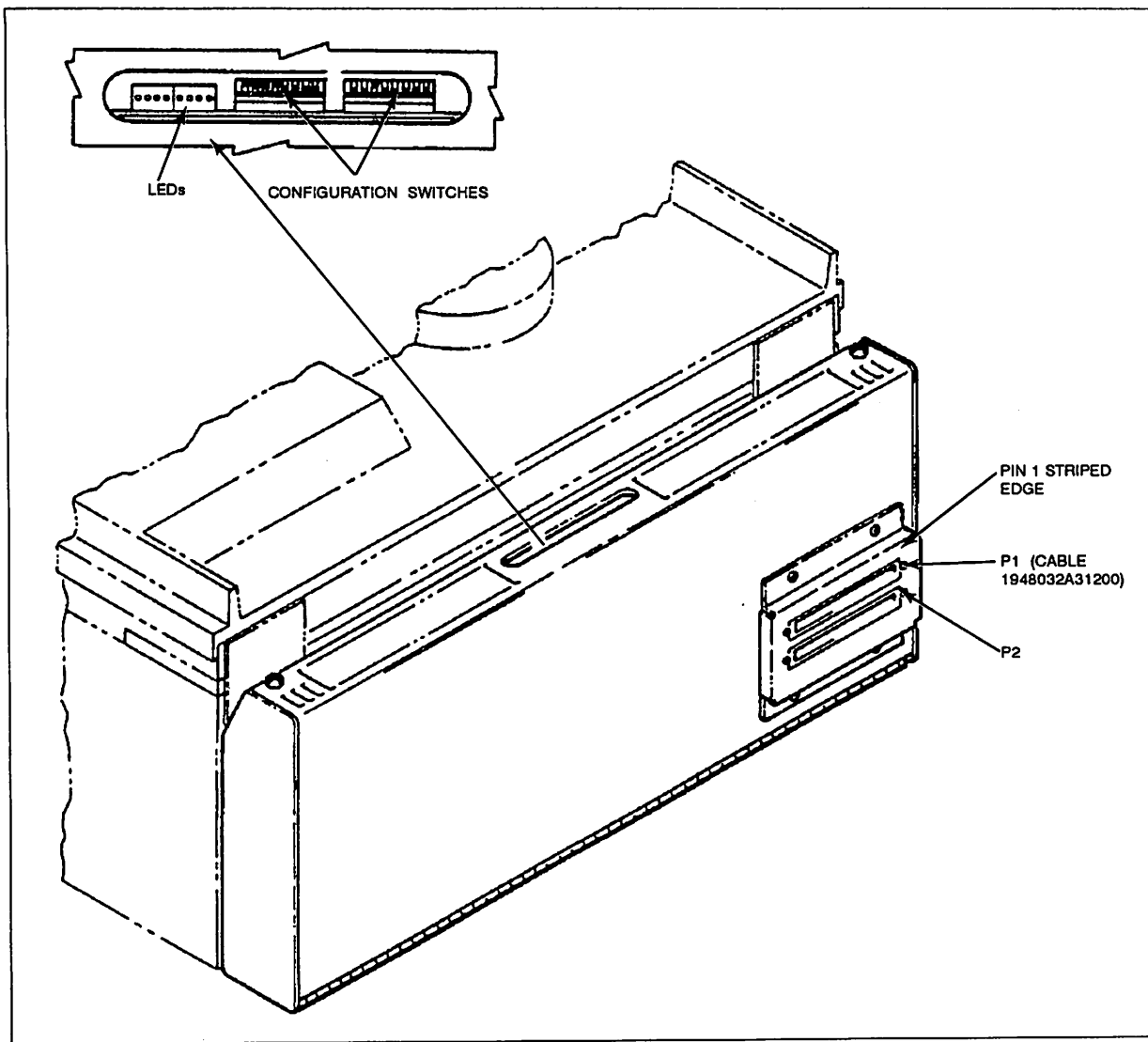
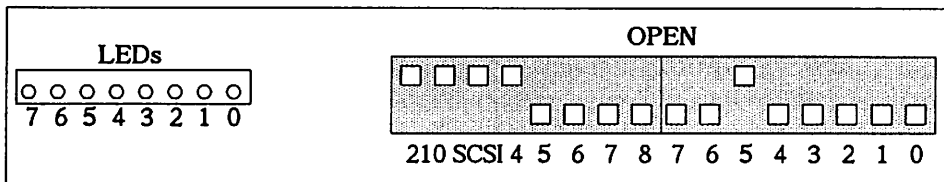

Figure 4-8. LED and Switch Location



---

---

## NINE TRACK REEL-TO-REEL TAPE TRANSPORT

### System Interconnections

1. Rotate power rotary selector at rear of tape transport. Set to appropriate mains voltage and frequency. If voltage is 200 to 240 V ac, pop out (screwdriver 1/4 turn CCW) adjacent fuse holder and replace fuse with 3A slow blow fuse provided.

2. Use the parallel blade cord from transport's IEC-320 receptacle to MCS CRT02's J4 Power or J5 Spare receptacle as available. If installed in MED driver cabinet, use IEC320 Male to Female cable P/N 19447950\_5 and connect to power entry panel Utility receptacle.

3. With front panel power switch rocked and left permanently on, (system running) measure voltage at transport rear J9 connector, white wire, and confirm that it is +50V DC with respect to the black wire. Correct as necessary.

4. Turn off each MCS cabinet breaker and attach the CSC-100 units P/N 962031 P2 connector to transport connector J9.

5. Attach left and right ribbon cable P1 connectors to transport connectors P1 and P2 respectively. Cables have stripe to right at transport rear. Cables do not cross.

6. Dress cable tagged 962031 and transport power cable down through trough, then hook CSC-100 on rear of transport.

7. Attach grounding/hanger straps to screws at left and right of transport. Arrangement needs to look like a swing, as installed.

8. Dress the end of cable P/N 1948032\_31200 having the strain relief connector down left and front sides of NMED01 or NCRT02 card cage, striped edge down.

9. Attach the other end to either connector on the rear box of CSC-100, strips to right. Fully seat the connector.

## NINE TRACK REEL-TO-REEL TAPE TRANSPORT

### Disk Server Upgrade

1. Observe anti-static procedures. Remove disk server card 11 and 12 pair, noting cable attachments for reinstallation.
2. Install C2 or later current EROMs in locations U19 and U27.
3. Locate, plug-in, and screw down SCSI ISBX adapter P/N 6637337\_1 at location P4.
4. Re-install boards and cables. Attach cable P/N 1948032\_31200 to visible connector of SCSI board. Position striped edge down at all ribbon connectors.
5. Remove fastener from squared-off end of 1/2 inch tape 1200 or 2400 feet reel, and insert with tape uncoiling clockwise through hinge-up doorway (Figure 4-9).
6. Fully seat tape on hub, then close door. Turn on power to each MCS cabinet, and immediately press transport's load, then on-line

buttons. It's good to press the MCS reset a couple of seconds after turning the breaker ON. Whenever the display does not confirm a successful load, load manually by:

- a. Grasp lower left hand door release behind faceplate, squeeze and glide-out transport.
- b. Lift hood (chock drops into position).
- c. Thread tape through maze then (holding tachometer arm away) wrap six winds clockwise around take-up hub.
- d. Lift chock, close hood and retract transport.
- e. While pressing Density button, press Load, then press on-line.

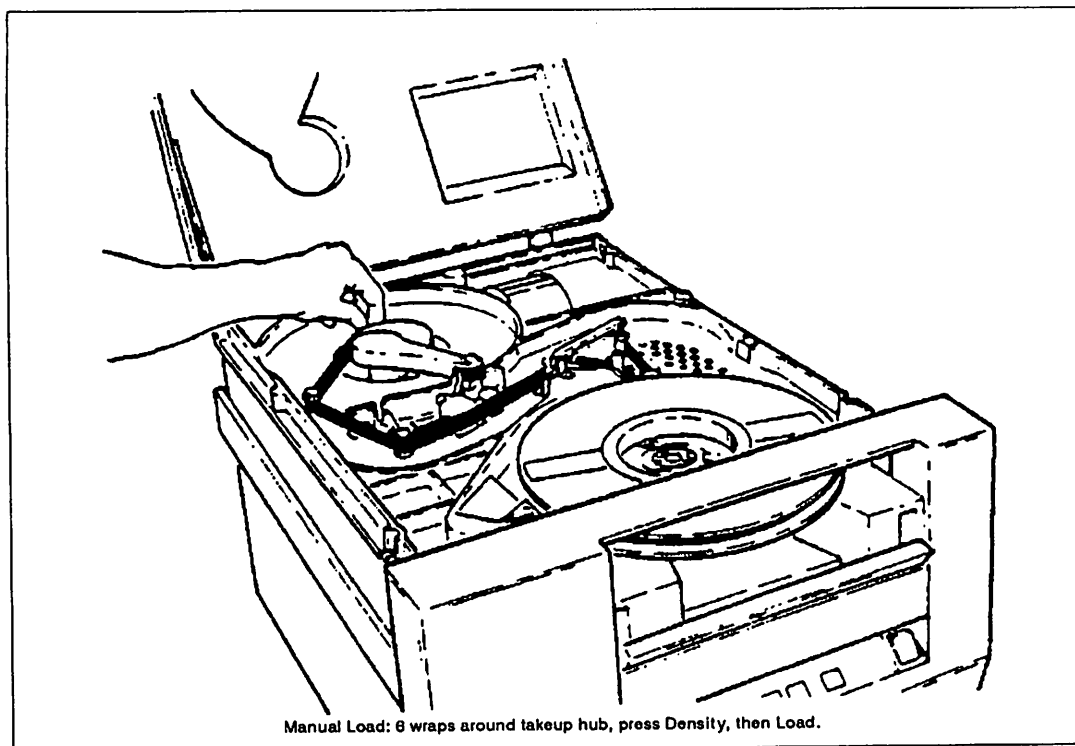

Figure 4-9. Loading Tape

## PRINTER

Bailey\_P/N NPRT02 Black and White Printer serial interface

A maximum of four printers may be added to the MCS. Refer to I/O DISTRIBUTION BOARD in Section 3 for socket allocation. Plug the printer into the appropriate I/O Distribution Board socket. Printers supported are:

GENICOM 3400, 3410 with firmware 506111, 507256 respectively

GENICOM 4440 model A with firmware 44A507470

GENICOM 4440 model B with firmware 44A512090

### NOTES:

1. For distances over 100 feet, optical modems (using up to 1000 feet of fiber optic cable) are required.

2. Emulation Mode may be either IBM or GENICOM: ANSI x3.64.

The standard printer configuration available from the printer is:

The Present Configuration is: (00506111)

1. Font:  
Style - (44\_506153) Draft  
CPI - 12.0  
Country - USA  
Mode - Normal
  2. LPI - 6
  3. Forms Control:  
Form Length - 11.0"  
Top Margin - 0.0"  
Bottom Margin - 0.0"
  4. Interface Control:  
Interface Type - Serial  
Input buffer length 0512  
Interface Straps A:  
0 1 2 3  
12345678901234567890123456789012  
00001000000010000000100000001000  
Interface Straps B:  
0 1 2 3  
12345678901234567890123456789012  
00000000000000000000000000000000  
Speed - 9600  
Parity - Space
  5. Margin Settings  
Left Margin - 0.0"  
Right Margin - 13.6"
  6. Horizontal Tab Stops:  
None
  7. Vertical Tab Stops  
None
  8. Printer Control Straps:  
Printer Straps A:  
0 1 2 3  
12345678901234567890123456789012  
10001000101100000000000000000000  
Printer Straps B:  
0 1 2 3  
12345678901234567890123456789012  
00000000000000000000000000000000
  9. Emulation Mode - IBM
- Press the number 0 to return to normal operation.  
To continue modification select (1-8).

# REDUNDANCY TRANSFER SWITCH

Bailey P/N - NMRT01

## Description

The MCS Redundancy Transfer Switch (MRT) is used to switch control of four keyboards, four monitors, and two line printers between one of two Management Command System Driver Electronics (Figure 4-10).

The switch is a 5" x 19" x 9" open box with two circuit boards and a power supply. It is designed to mount on a standard 19 inch EIA

rack. The NMRT01 replaces the I/O Distribution Board and is mounted in the same location. It mounts inside the NMED01 driver cabinet, or in the NMCS01 with rack adapters.

The MRT provides a fail safe configuration mode which transfers all peripherals to the secondary MCS driver cabinet should the primary fail.

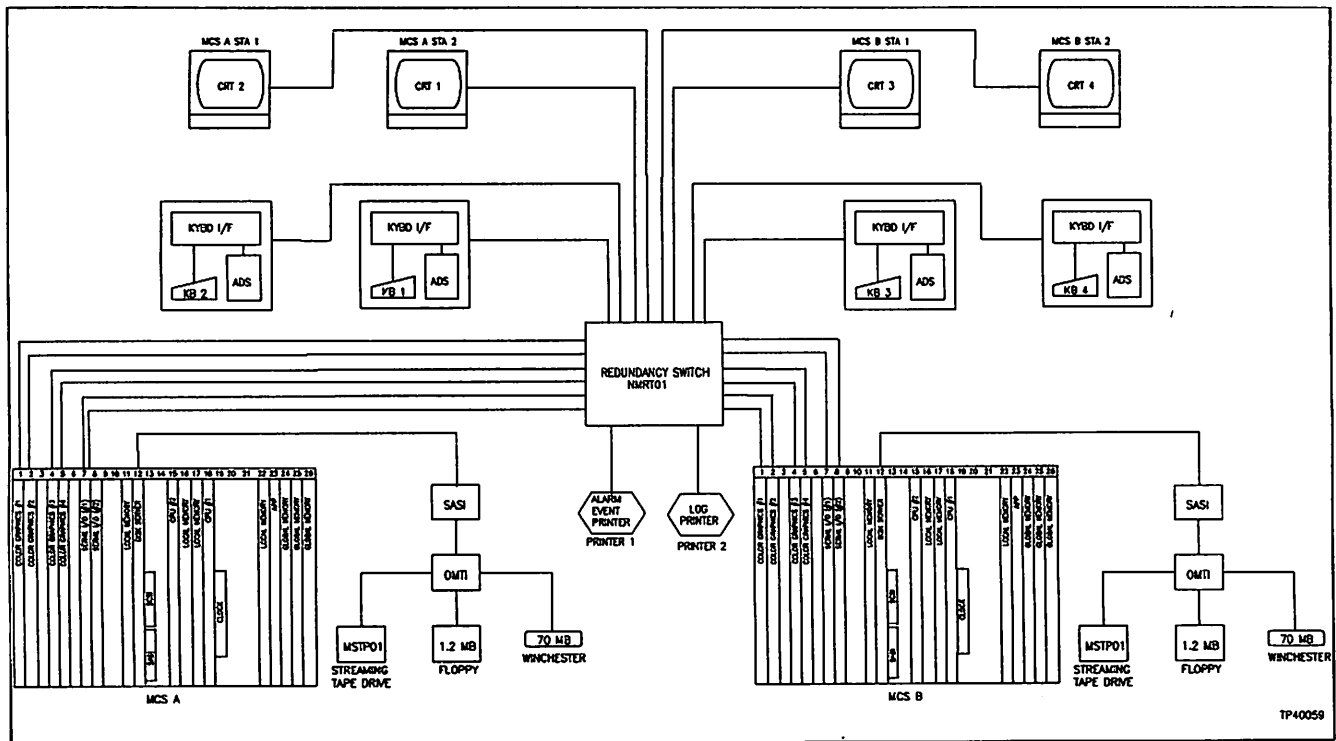

Figure 4-10. MCS Hardware Configuration Using the NMRT01

## REDUNDANCY TRANSFER SWITCH

### Operation

When the external switch is in the MCS A position (Figure 4-11), all four keyboards, the four monitors, and both line printers are driven by the MCS A driver electronics. Conversely, when the switch is in the MCS B position, the assigned peripherals are driven by the MCS B driver electronics.

When the external switch is in the USER SELECT position, the user may select which MCS driver electronics is assigned to the peripherals by activation of the rocker switches (Figure 4-11).

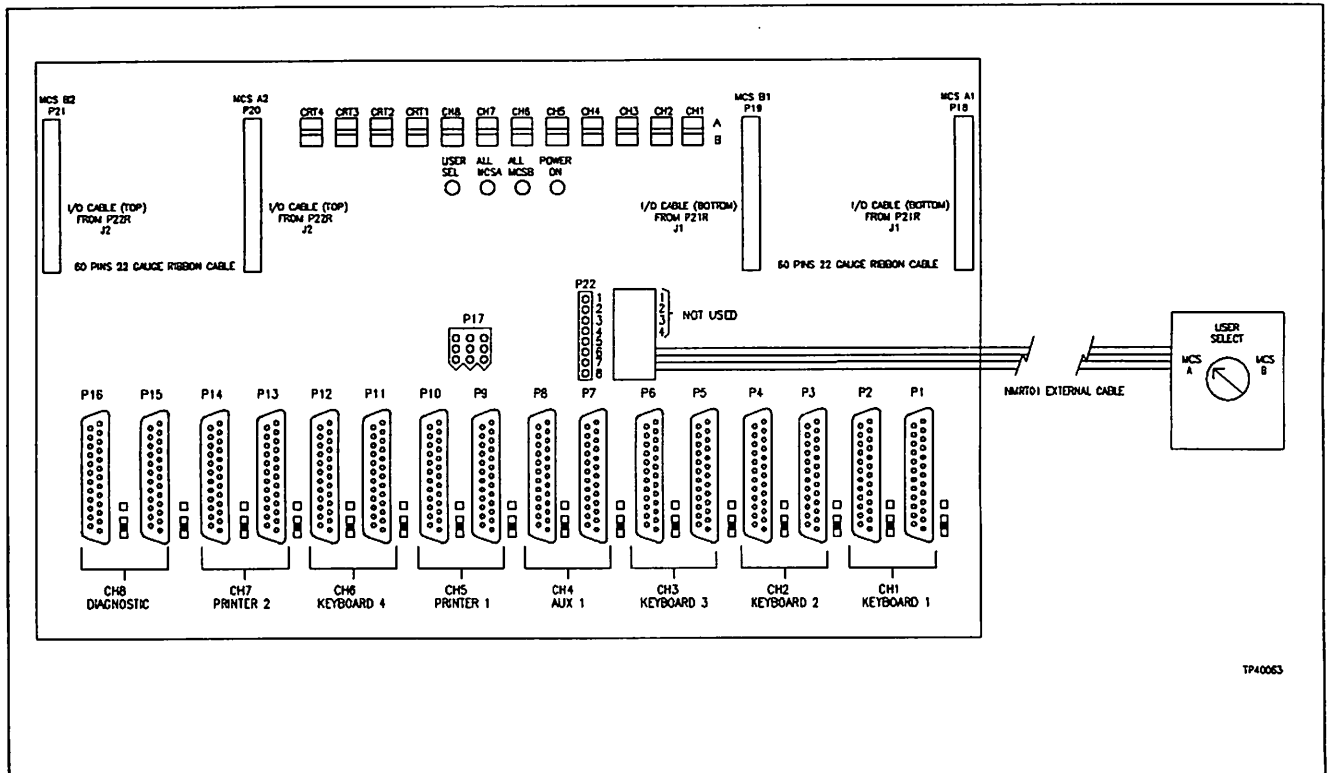

Figure 4-11. NMRT01 Top Circuit Board

---

---

## REDUNDANCY TRANSFER SWITCH

### Top Circuit board

The four keyboards and line printers are connected to the top circuit board via RS232 cables and 25 pin DB connectors:

Peripheral	RS232 Connector
Keyboard 1	P1
Keyboard 2	P3
Keyboard 3	P5
Keyboard 4	P11
Printer 1	P9
Printer 2	P13
CIU (MCS A)	P8

**NOTE:** Even numbered connectors are assigned to the CIU's and are always connected to MCSA. The diagnostic port is connector P15.

Sixty pin ribbon connectors are connected from the I/O boards in the MCS's:

I/O Panel Connector	NMRT0 Connector
MCS A, P21R (SCI J1R)	P18
MCS B, P21R (SCI J1R)	P19
MCS A, P22R (SCI J2R)	P20
MCS B, P22R (SCI J2R)	P21

Ribbon Cable	P/N
74 inches	6632686_60-1
10 feet	1948524_10
15 feet	1948524_15
20 feet	1948524_20

The rocker switches across the top of the board (Figure 4-11) are used to select assignment of peripherals when the external switch is in the USER SELECT position. The position of the external switch along with POWER ON are indicated by four red LED's on the circuit board (Figure 4-11).

## REDUNDANCY TRANSFER SWITCH

### External Switch

The external switch connector (Figure 4-12) is polarized. Pins 5, 6, 7, and 8 of P22 (Figure

4-11) are wired to the switch. The maximum distance from the NMRT01 to the switch is 90 feet.

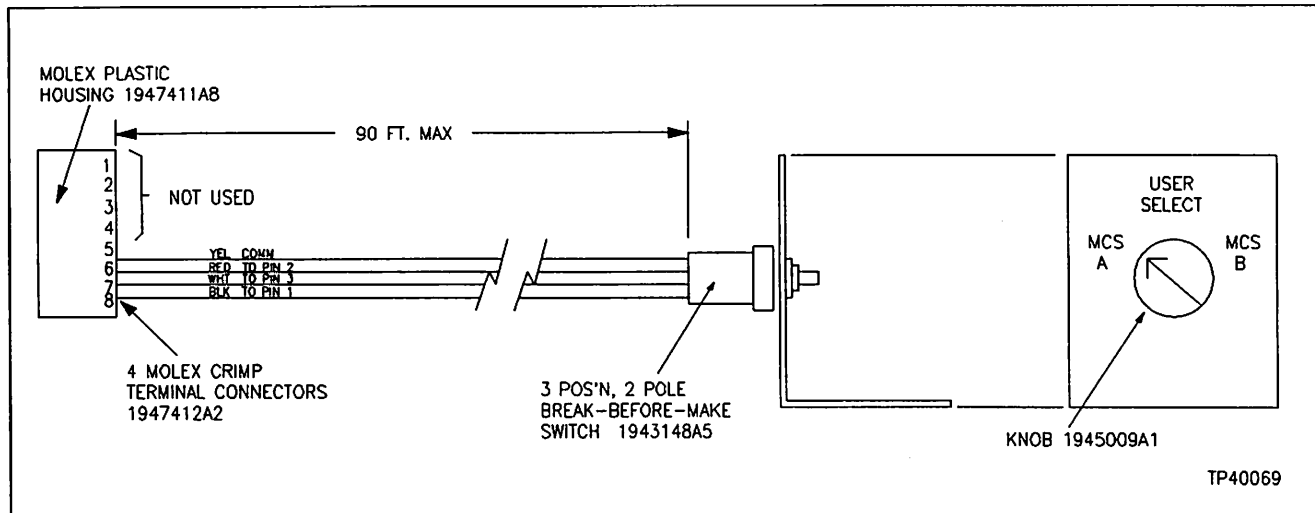

Figure 4-12. NMRT01 External Switch

# REDUNDANCY TRANSFER SWITCH

## Bottom Circuit Board

The red, green and blue coaxial cables from the driver display (MATROX) boards in the MCS.s are connected to the respective BNC connectors on this board (Figure 4-13).

The power supply is connected to a 120 V ac outlet on an MCS, or the 120/240 V ac outlet on the NMED01 power entry panel. Set the jumpers on the power supply (shown in Table 4-4) for the appropriate input voltage level.

Table 4-4. NMRT01 Power Supply Jumper Settings

Voltage (Vac)	J18	J19	J20	J21	J22	J23
100	o-o o	o-o o	o-o o	o o-o	o o-o	o-o o-o o
120	o-o o	o-o o	o-o o	o-o o	o-o o	o-o o-o o
220	o o-o	o o-o	o o-o	o o-o	o o-o	o o-o o-o
230/240	o o-o	o o-o	o o-o	o-o o	o-o o	o o-o o-o

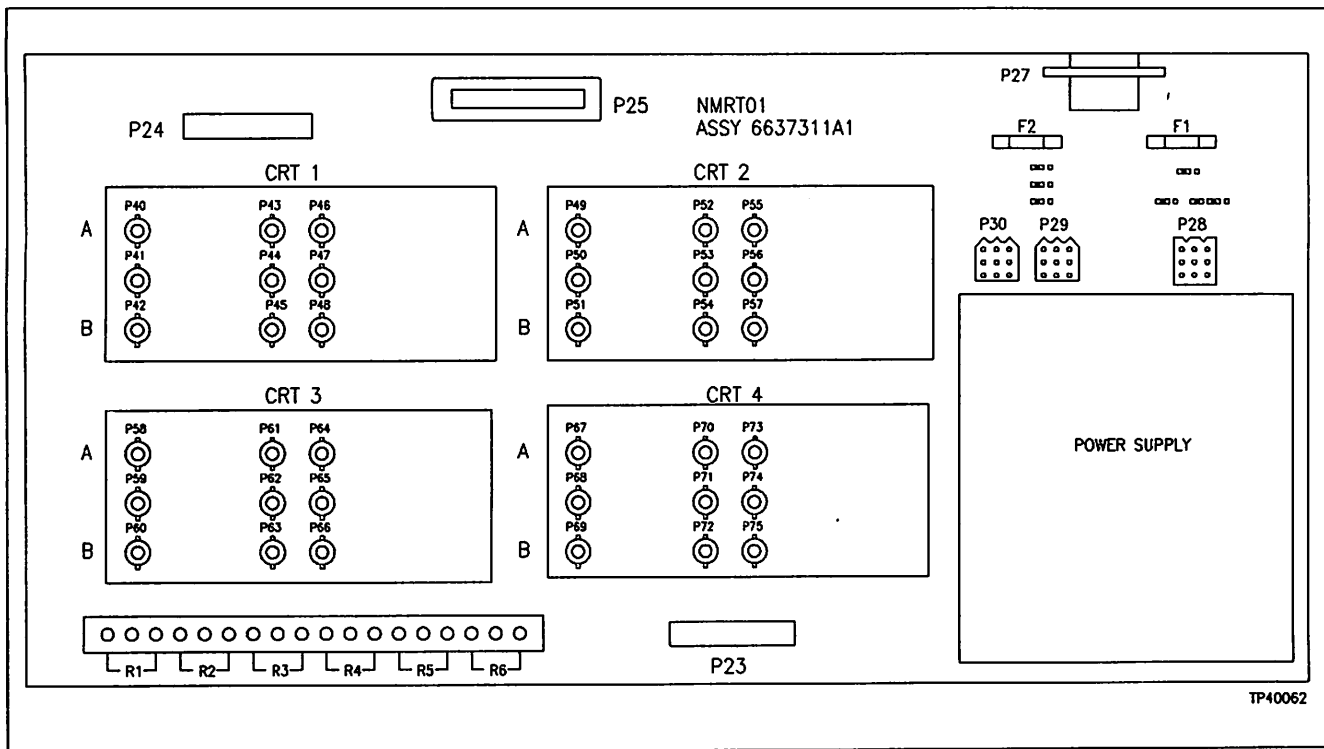

Figure 4-13. NMRT01 Bottom Circuit Board



## REDUNDANCY TRANSFER SWITCH

### System Configuration

All the monitors, keyboards and line printers must be configured the same in both driver electronics. To accomplish this, position the external selector to the MCS A and configure all the peripherals which are to be assigned to the MCS A driver electronics. After MCS A is configured, repeat the procedure for MCS B. Note that the monitor, keyboard and printer assignments must be the same for both driver electronics.

NMCS02 or NMED01. For the NMCS02, special brackets are included with the assembly to mount it behind the multibus card cage. For the MED01 the brackets may be discarded since the weldment is designed for use with an EIA standard 19 inch rack, as found in the NMED01.

PCI is located on the MRT on a hinged frame that allows it to swing down for access to PCII and the power supply section (Figure 4-14).

### Mounting

The MRT mounts in the same way that the I/O Distribution board mounts in a standard

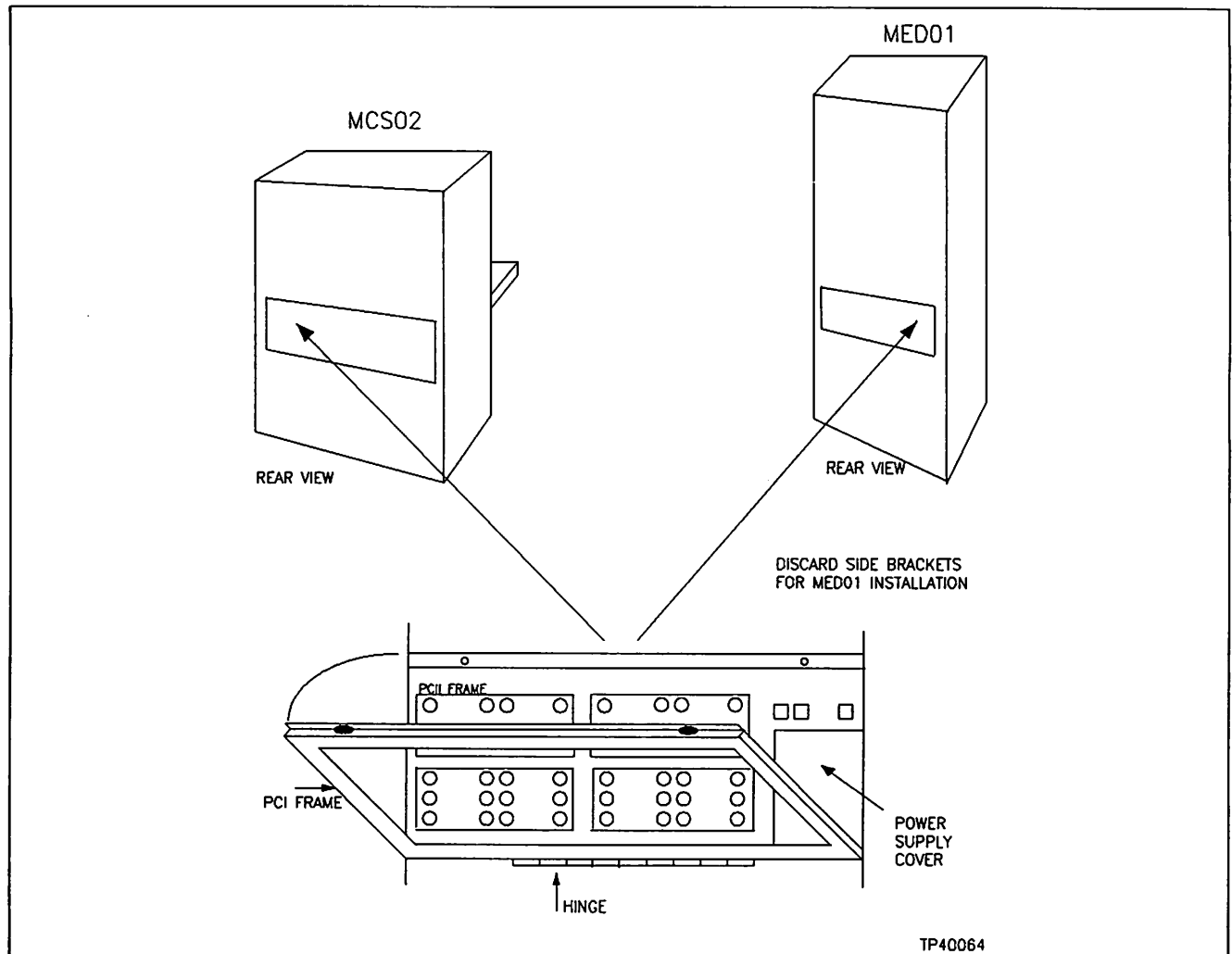

Figure 4-14. MRT Mounting

# REMOTE ELECTRONICS DRIVER CABINET (MED)

Bailey P/N - NMED01

The MCS Remote Electronics Driver Cabinet (NMED01) provides protection from industrial environments for NETWORK 90 hardware, while allowing monitors and central processing units to be cabled away in a cleaner environment.

The MED cabinet measures 87" x 24" x 30". It contains the same driver electronics as the NMCS02, and is configured in the same manner. The front and rear views of the MED are shown in Figure 4-15.

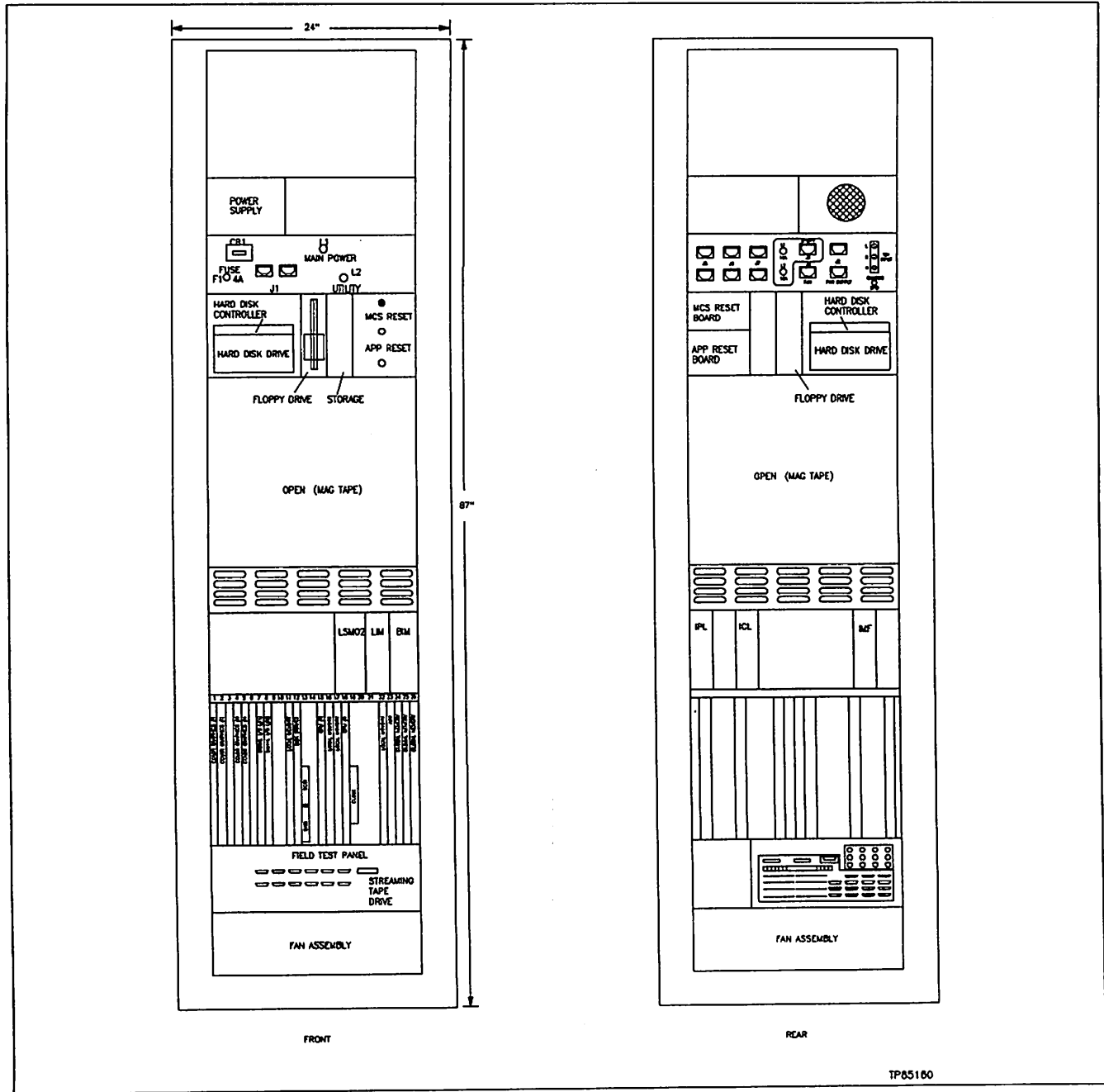

Figure 4-15. Front and Rear Views of the NMED01

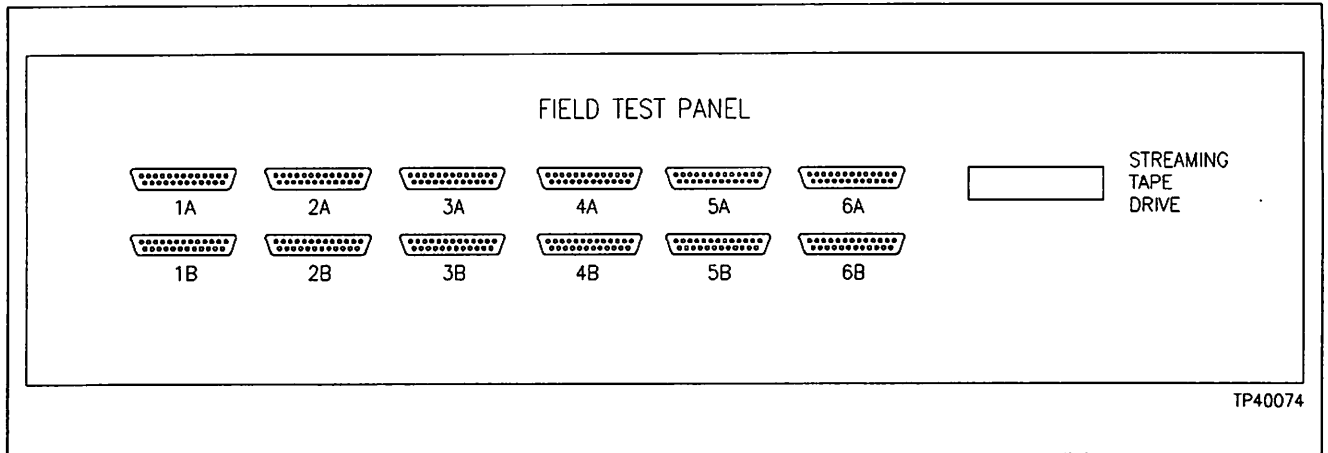

Figure 4-16. Field Test Panel

Table 4-5. Wiring Connection to Field Test Panel

1A/1B	2A/2B	3A/3B	4A/4B 5A/5B	6A	6B	Streaming Tape
To P5 connector on Disk Server Card	To P5 connector on CPU Card 2	To P5 connector on CPU Card 1	Unused	To J3 connector of assembly number 6636488_1 to NLSM02	Unused	To J8 connector on Disk Drive Controller Card
Use cable number 1948200_50N14					Use cable number 6637460_50N93	

## POWER ENTRY PANEL (PEP)

Bailey P/N - 6637587\_1

Power is supplied to the MED through the Power Entry Panel (PEP). Refer to Section 2, **INSTALLATION AND START-UP**, for

connecting AC power. Table 4-6 contains the wiring connections to the PEP.

Table 4-6. Wiring Connections to the PEP

J2	Socket Number J4 (Fan)	J5 and J6	J7	From TB1 Input	From PEP Chassis GND
<p>Use wire assembly 6637599_1;</p> <p>Connect to terminal block on Power Supply:</p> <p>Brown wire to terminal L blue wire to terminal N</p> <p>Green/yellow wire to terminal G</p>	Power to fan assembly	Modems (optional)	Mag Tape (optional)	To AC Power source	<p>To Chassis Ground with green wire 6637448_1</p> <p>To Power Supply, use wire assembly</p> <p>connect: One green wire to CH1 NEG,</p> <p>One green wire, terminal block, G terminal</p>

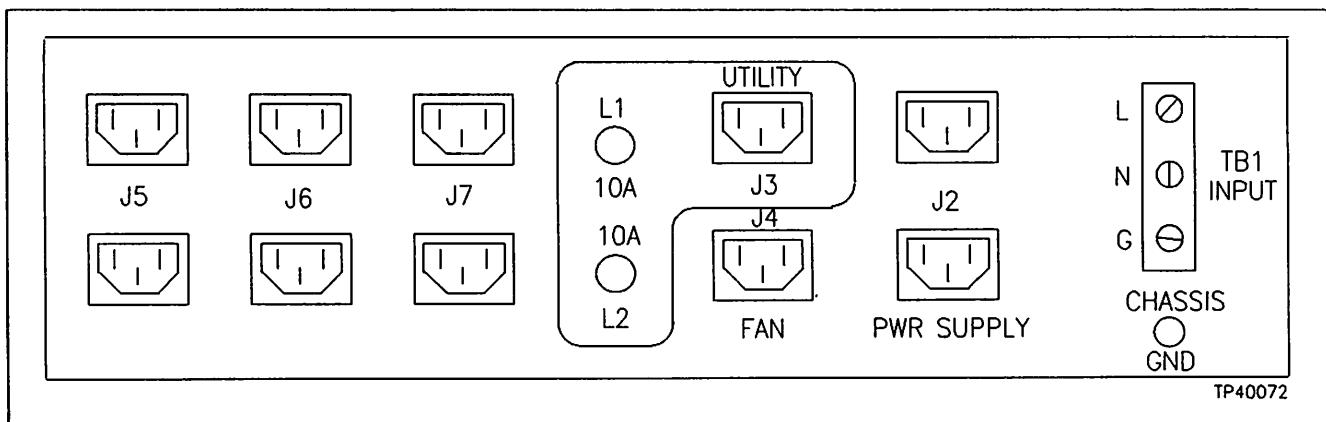

Figure 4-17. Power Entry Panel (PEP)

## SCSI NINE TRACK REEL-TO-REEL TAPE TRANSPORT ADAPTER

Bailey P/N - 6637337\_1

The Small Computer System Interface (SCSI) adapter (Figure 4-18) interfaces a nine track reel-to-reel tape transport to the MCS. For more information on this tape transport, refer to **NINE TRACK REEL-TO-REEL TAPE**

**TRANSPORT** in Section 4 of this manual. The SCSI adapter plugs into the Disk Server card (refer to **Disk Server Card** in Section 3 of this manual). Configure the adapter by setting the jumpers as shown in Figure 4-18.

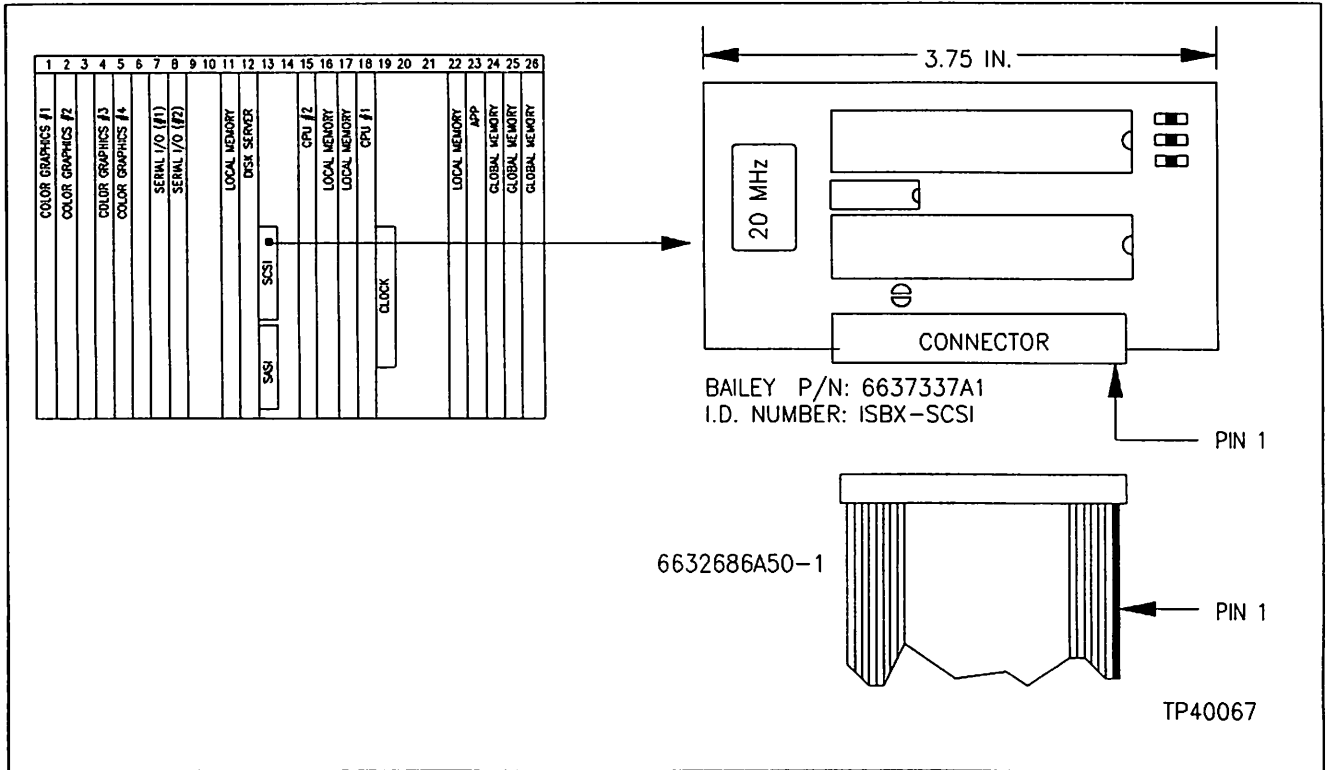

Figure 4-18. SCSI Adapter Card

## STREAMING TAPE DRIVE

Bailey P/N - NSTP01

The NSTP01 Streaming Tape Drive peripheral is a 60 Mbyte cartridge tape drive with a QIC02 Interface and power supply housed in an APC half-case enclosure. It is used to perform backups of the MCS hard disk with the command BU and restores with the command RU. The backup/load process may be completed in about 40 minutes, depending on the interleave factor. For 85 Megabyte drives, attendance is required midway to completion of each command to remove the first tape and insert the second. The Disk Controller used by the MCS also controls the tape drive.

A kit (P/N 258433\_1) is available to adapt to the rugged 50 pin blue ribbon receptacle (Figure 4-19) supplied on the front panel of those MCS systems shipped since the fall of 1987. The streaming tape unit is supplied with a blue ribbon D plug. Refer to Figure 4-19 to attach the cable (P/N 1948325\_50) between the controller board J6 connector to the front panel D receptacle.

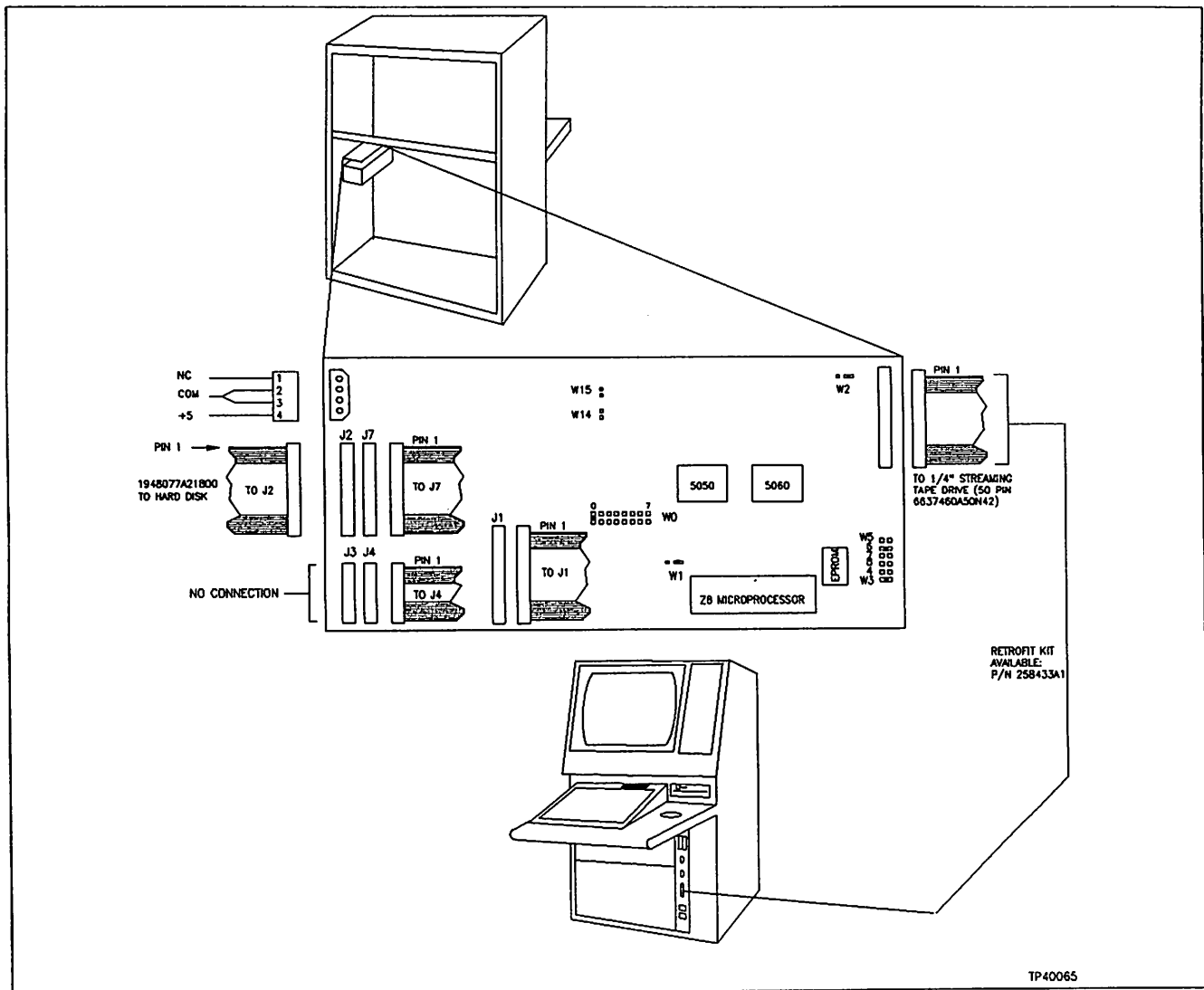

Figure 4-19. NSTP01 Cable Connections

# STREAMING TAPE DRIVE

The tape drive unit contains a controller board which requires configuration by setting jumpers. The jumper settings are factory set and should require no further configuration. To verify the settings, refer to Figure 4-20.

### Backup and Restore Operation

Connect the terminal to the Monitor 68K diagnostic port on the Disk Server Card. Reset the MCS, and press <Enter> on the terminal within seven seconds. Enter the command BU to

backup the MCS hard disk to tape, or the command RU to restore the hard disk from tape.

A 55 Mbyte hard disk backup must be restored back to a 55 Mbyte hard disk, with one tape required. An 85 Mbyte hard disk backup must be restored back to a 85 Mbyte hard disk, with two tapes required. A 170 Mbyte hard disk backup must be restored back to a 170 Mbyte hard disk, four tapes required.

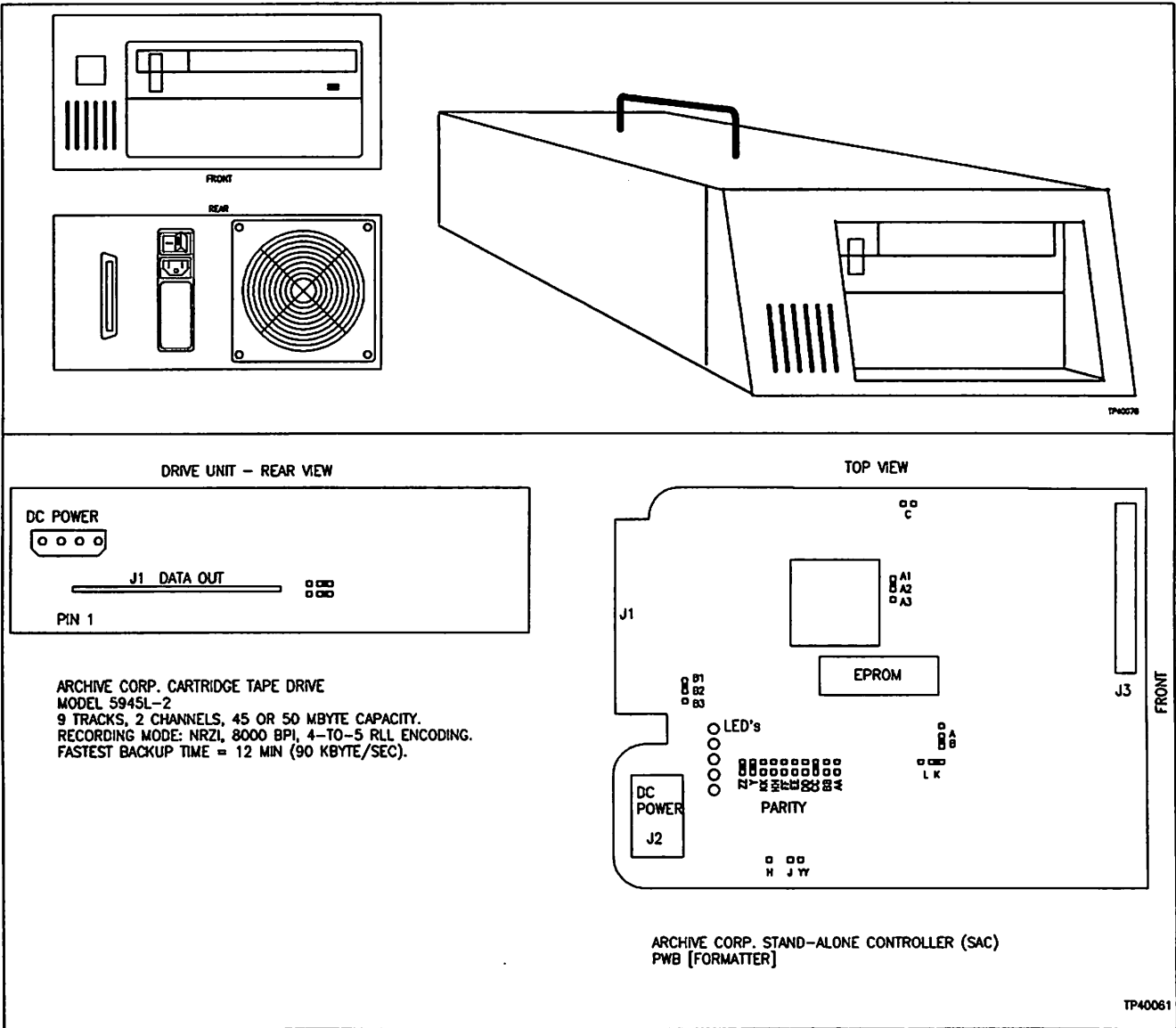

Figure 4-20. Tape Drive and Internal Controller Card Jumper Settings

---

---

## **SUPERLOOP COMPUTER INTERFACE UNIT**

Bailey P/N - NCIU04

The Computer Interface Unit enables the MCS to interact with the NETWORK 90 system through Superloop. This interface consists of

the Loop Interface Slave and the Superloop Storage Module.



**SUPERLOOP COMPUTER INTERFACE UNIT**

**Loop Interface Slave  
Bailey P/N - NLIS01**

The Loop Interface Slave module is the front end of all Superloop interfaces. It provides the intelligent link between a node and the Superloop. (Refer to Bailey manual E93-908-7 for more information concerning this module). Refer to Figure 4-21 for dipswitch and jumper settings. For the NMCS02, an NKLS01 cable connects the NLIS01 to the NTCL01 Termination Unit. For the NMED01, an NKLS02 cable connects the NLIS01 to the NICL01 Termination Module.

**NOTE:** Jumpers J1 to J6 and switches SW1 and SW2 are dependent on your superloop configuration. Refer to Bailey Manual E93-908-7 for more information concerning these settings.

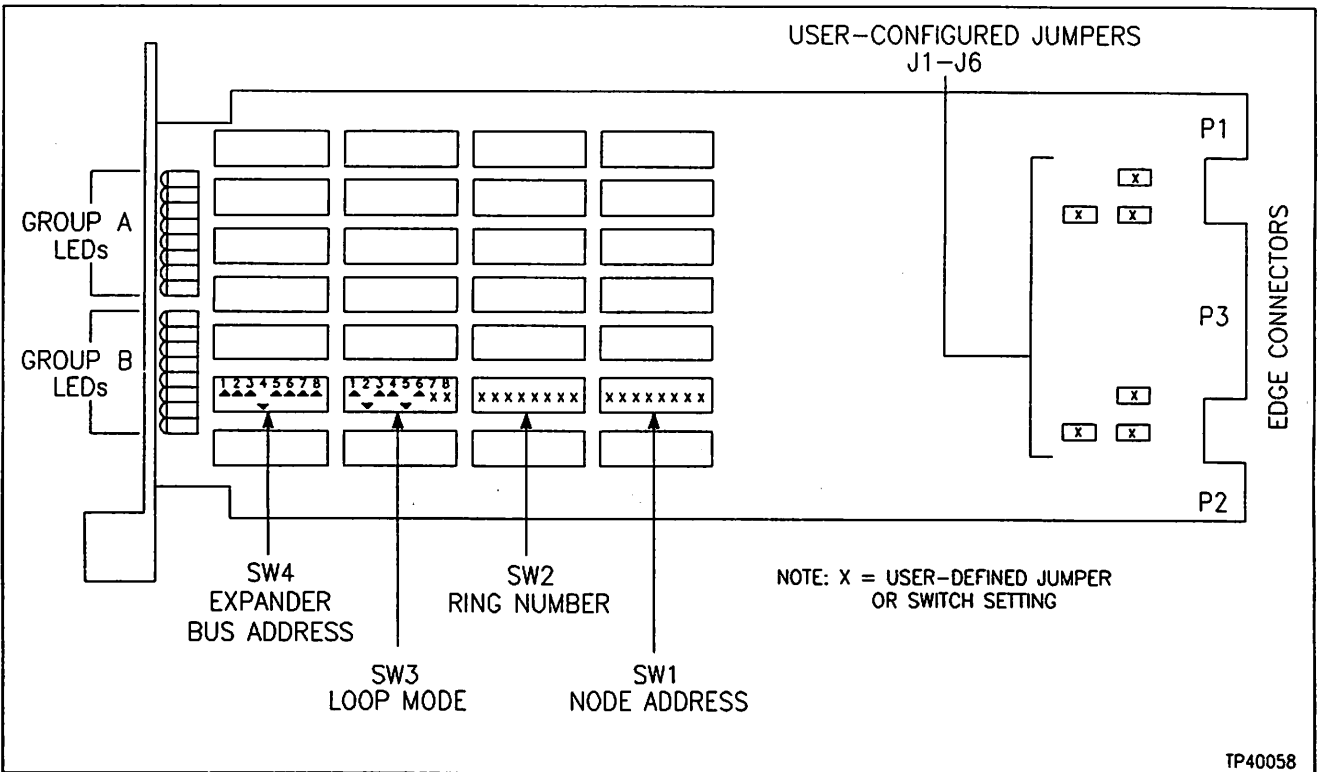

*Figure 4-21. Loop Interface Slave - NLIS01*

**Superloop Storage Module**  
Bailey P/N - NSSM01

**SUPERLOOP COMPUTER INTERFACE UNIT**

The LIS receives frames from the Superloop and passes them on to the Superloop Storage Module (SSM) for processing. The SSM then sorts this incoming data, storing exception reports and incoming requests until the MCS is ready for the data. (Refer to Bailey manual

E93-908-7 for more information on this module) Refer to Figure 4-22 for dipswitch configuration. Cable assembly number 6636488\_2 provides the necessary connections to the NSSM01.

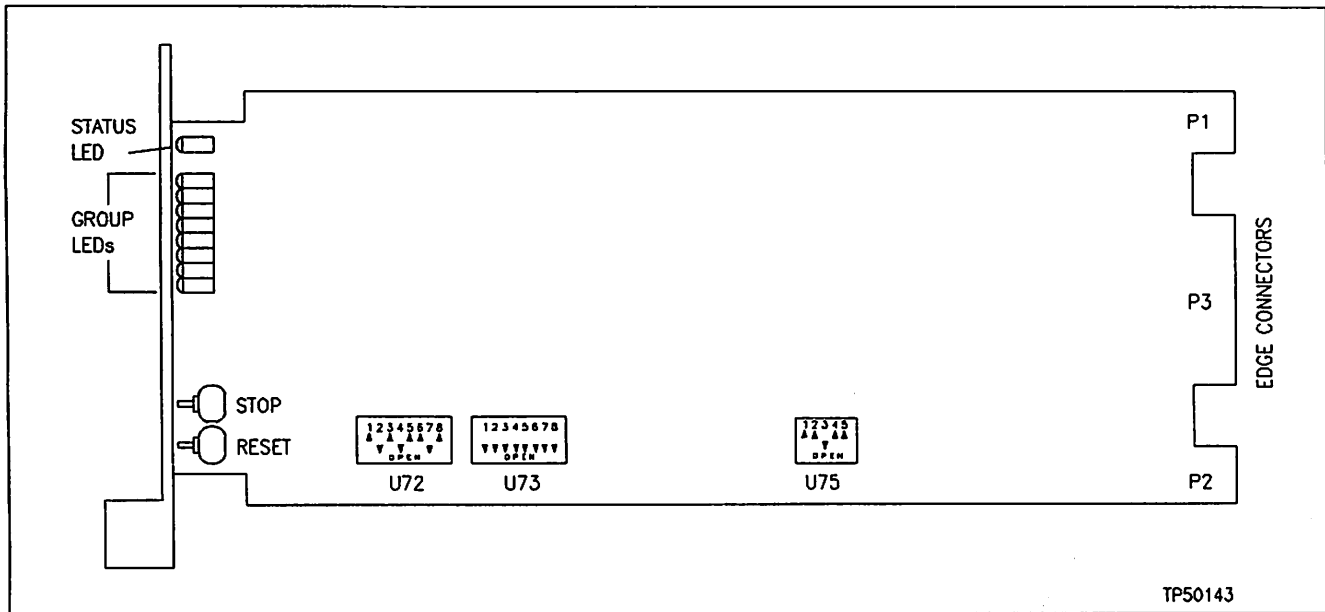

Figure 4-22. Superloop Storage Module - NSSM01

---

---

## TOUCH SCREEN

Bailey P/N - NSCT01, NMTS01, NMTS02  
includes:

19 inch Touch Screen 1948026\_1

25 inch Touch Screen 1948026\_2

Touch Screen Controller Card 1948027\_2

Associated cables and hardware

A Touch Screen provides a means of moving the screen cursor and selecting display options by touching the desired area on the monitor screen. One touch screen per color monitor and keyboard electronics card can be added. This option requires the addition of a touch screen and touch screen controller card. Two versions of the touch screen (1948026\_1) are in use, one using a three wire lead and one using a five wire lead. Two versions of the controller card are in use, 1948027\_2 (I.D. Number E217-60MKII, single pot version) and 1948027\_1 (I.D. Number E271-60, five pot version).

### Touch Screen Installation

Remove the top cover of the MCS and position the touch screen in front of the color monitor. The NSCT01 is used with the NMCS02, NCRT01, and NCRT02.

### Touch Screen Controller Card Installation

Refer to Figure 4-24 for dipswitch settings and wiring connections of controller I.D. Number E217-60MKII, and Figure 4-25 for controller I.D. Number E271-60.

Prior to attaching the touch screen ribbon cable to the controller board, the capacitive charge on the touch screen must be bled to the monitor case ground.

1. Insert one end of a straight pin or 24 AWG wire into either outside touch screen connector contact (of either the three or five wire lead).
2. Press the other end of the pin or wire to the monitor case ground.

Failure to perform this may result in loss of mos-FETS on the controller by stored charge coupled from the pulsating 25kV anode potential during picture tube operation.

If connecting a three wire touch screen to a five contact touch screen controller board, plug the touch screen connector onto the center three pins. If the controller card is the Bailey P/N 1948027\_2 (I.D. Number E271-60MKII), a jumper is required on two pins located at the center of the board (Figure 4-24).

## TOUCH SCREEN

### Calibration

To calibrate, a terminal must be attached as shown in Figure 4-23. Set a serial communications terminal to 600 baud, 8 databits, 1 stop bit. The terminal must be set for full duplex (not block mode). Connect the terminal to the RS232-C connection on the Touch Screen Controller board (Figure 4-23). Follow the instructions on the following pages for the touch screen controller board in use.

When testing, use a display that utilizes the full screen (10,000 by 7,500). Graphics card test number 4 (see test command GT given in the advanced EPROM diagnostics, Section 5) is good for this purpose. The touch screen (and the MCS color monitor) extend beyond the edges of the console screen casing. Thus it is necessary to calibrate the touch screen only for the useful area (visible to the user) of the screen.

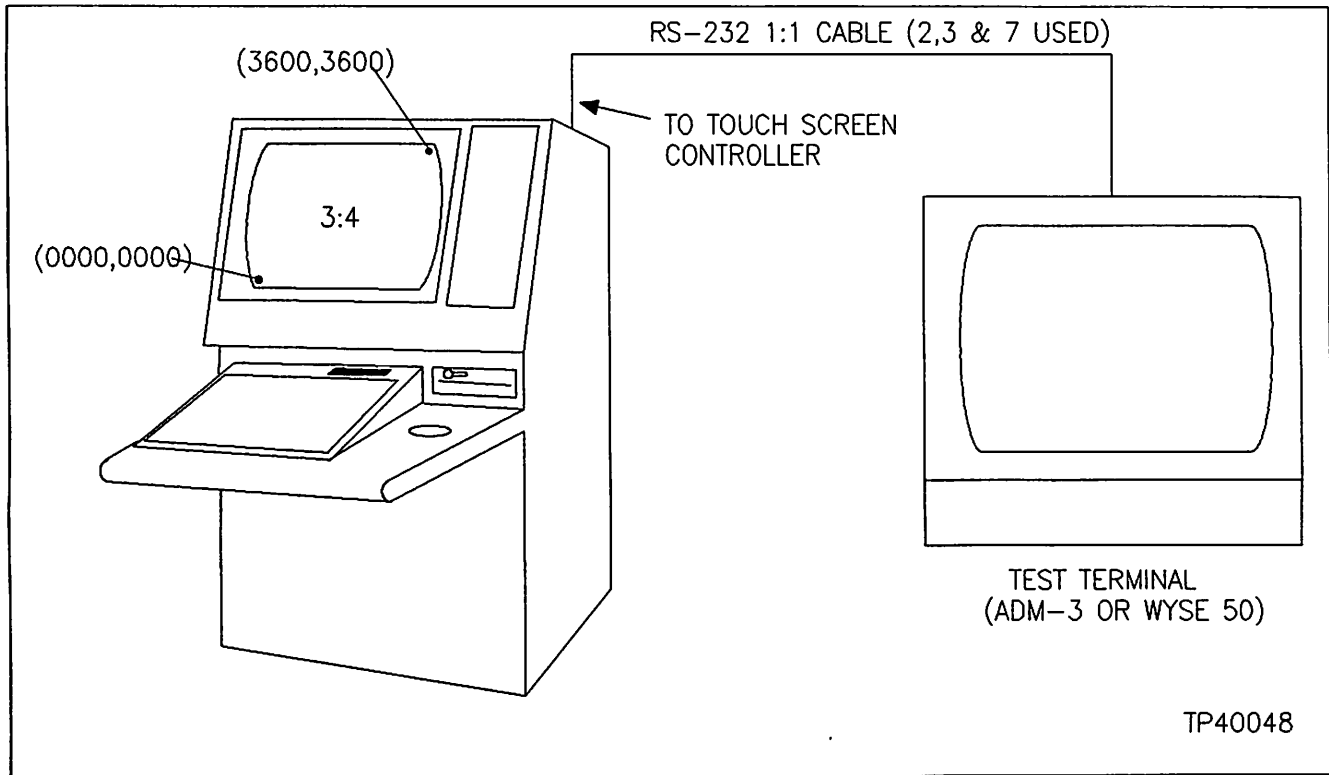

Figure 4-23. Manual Touch Screen Calibration

## TOUCH SCREEN

Calibration - Touch Screen Controller I.D. Number E271-60MKII (1947027\_2)

If MCS Software revision K.0 and the EMKI keyboard controller is installed, an on-line calibration utility is provided. Refer to the MCS Operation and Configuration Manual E93-901-21 for information on the use of this utility.

**NOTE:** The ROM label on the touch screen controller board must have the checksum 1448. If this checksum number is not on the ROM label, contact your nearest Bailey Service representative to obtain an update.

1. When the controller is sent the proper command, two 4-digit values representing the X and Y coordinates where the screen was touched will be displayed on the terminal. If the controller was retrofit to a three wire touch screen, these values may either not display or may display twice for each touch of the screen. If this is the case, the touchdown sen-

sitivity potentiometer should be adjusted. The touchdown sensitivity potentiometer is on the touch screen controller board, and is shown in Figure 4-24.

To adjust, turn counter clockwise until the count will not display on the terminal, then clockwise until displayed, and two turns further to assure proper operation.

2. To calibrate, type %C (upper case C) on the terminal. Call up a grid showing display active area edges, then touch in succession the lower left (0000,0000), then upper right (3600,3600) edges of the active area. Type %C and recalibrate as required. New calibration constraints will be generated, and stored in the controller board's non-volatile memory.

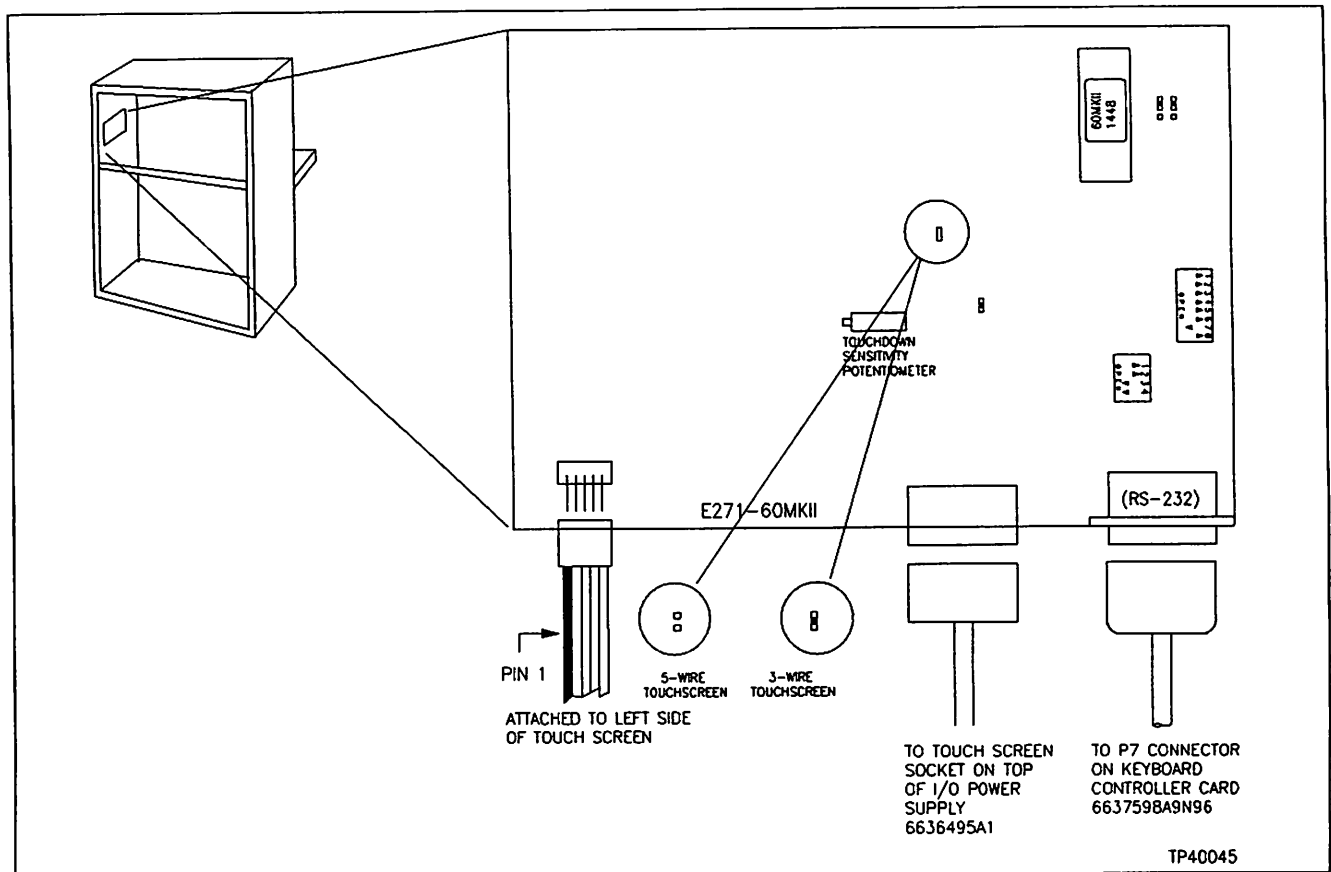

Figure 4-24. Touch Screen Controller Card - I.D. Number E271-60MKII

## TOUCH SCREEN

Calibration - Touch Screen Controller I.D. Number E271-60 (1947027\_1)

1. Adjust X ZERO (R3) and Y ZERO (R4) controls to get the XXXX,YYYY value as close to **0000,0000** as possible. Do not use the General Functions Menu to adjust your touch screen.
2. Touch the lower left corner of the screen. The test terminal should start displaying a stream of XXXX, YYYY coordinate pairs.
3. Touch the upper, right-hand corner of the screen. Adjust the X-GAIN (R2) and Y-GAIN (R1) controls to get a count of 3600,3600.
4. Repeat steps 1 through 3 at least two times, to dial-in the screen as close as possible.
5. After setting the zero and max points for the screen, try touching the screen at points 25%, 50% and 75% along the X and Y directions. Verify that for each of these points, the reading is approximately what is expected (900, 1800, and 2700 respectively). The required accuracy for this calibration is:
  - X zero -0%, +2%0 = 0 to 72 (min)
  - Y zero -0%, +2%0 = 0 to 72 (min)
  - X max -2%, +2%3600 = 3528 to (full) 3672
  - Y max -2%, +2%3600 = 3528 to (full) 3672

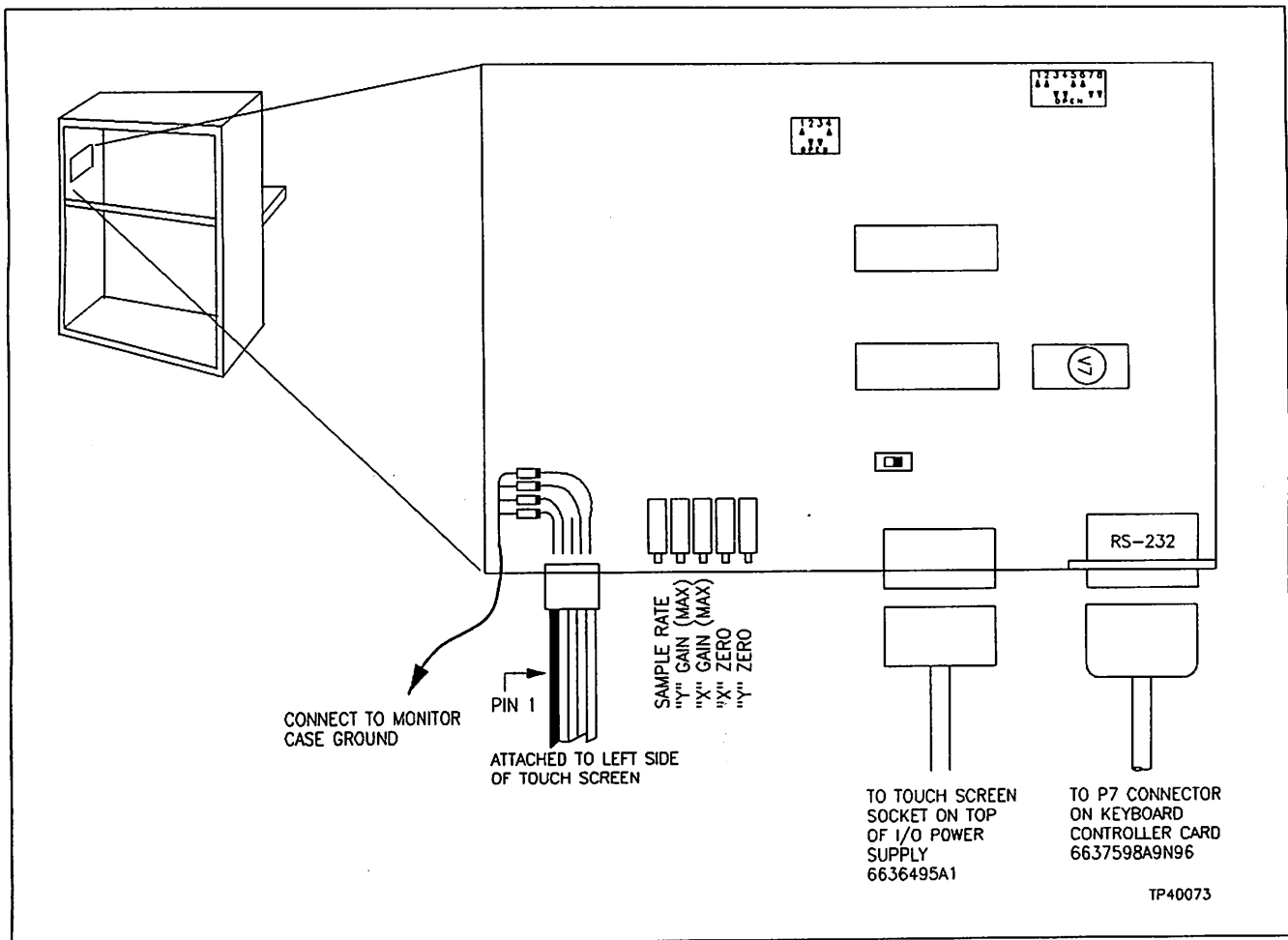

Figure 4-25. Touch Screen Controller Card - I.D. Number E271-60

The MCS Trackball option permits faster cursor positioning during normal operator control or configuration. This option requires the Enhanced MCS Keyboard (EMKI01) P/N 6637517\_1. Refer to MCS ENHANCED KEYBOARD INTERFACE CARD (EMKI) in Section 3 of this manual for cable connections.

**Trackball Installation**

The Trackball is mounted from the bottom of the console counter, using a sheet metal cover and four thread forming metal mounting screws. A quick disconnect style (telephone) cable connects the trackball to the keyboard electronics board EMKI.

**Parts List:**

Quantity	Part Number	Description
1	1948313_1	trackball
1	6634945_1	console counter
1	4843357_1	cover
6 inches	484692_2	sealing strip
1	1948318_818	cable assembly
4	NKDAC14008	1/2 inch long, #8 pan head thread forming screw
1	6637517_1	EMKI keyboard electronics

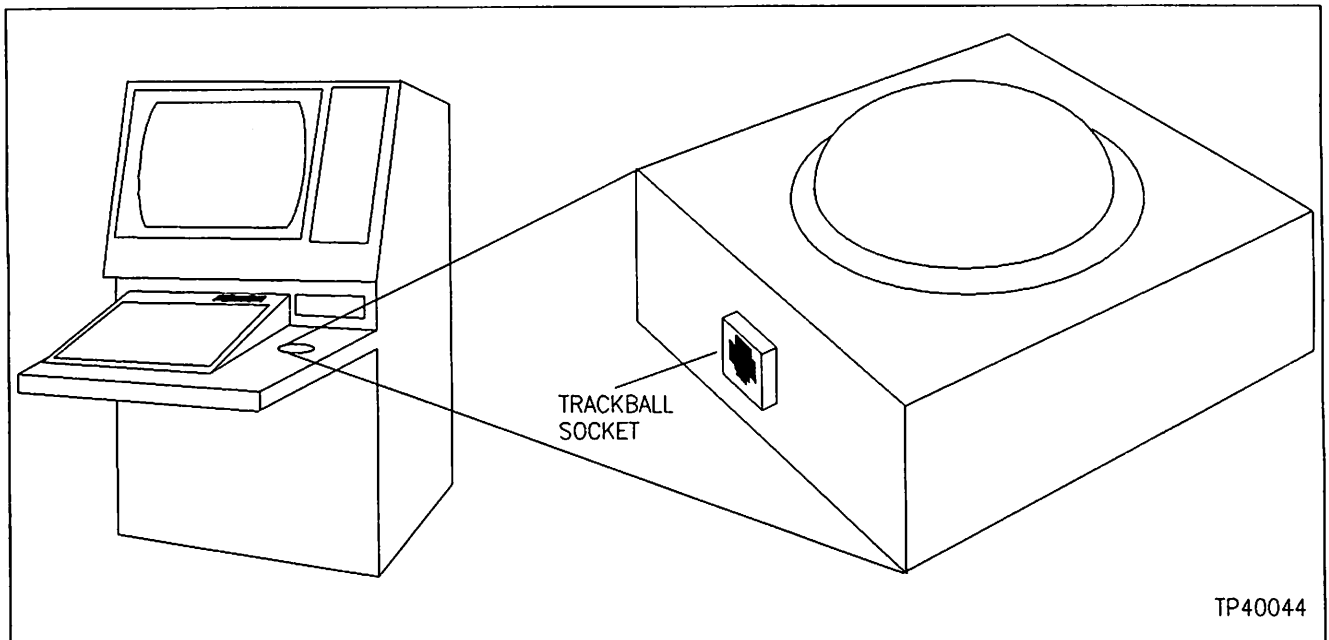

Figure 4-26. Trackball Location

---

## TRACKBALL

The following steps cover the installation of the trackball assembly.

1. Assemble trackball to the console counter. Insert trackball into counter slot, with cable socket pointing towards the keyboard.

**NOTE:** The ball and surrounding seal should fit snugly into the hole in the counter.

2. Place the trackball cover, with sealing strips, over the bottom of the trackball and attach to the cover with the four #8 pan head thread forming screws. Attach cable to trackball.

3. Assemble console counter to MCS. Turn off power to the MCS.

4. Remove the keyboard assembly from the sloped structural foam housing. Disconnect all cables to the console counter top (keyboard electronics, brightness control, etc.). Use a socket wrench and extension to remove the six 3/8 inch diameter bolts holding the counter top to the console (1/2 inch socket) and remove the counter.

5. Detach the perforated sheet metal keyboard electronics bottom cover and structural foam housing from the counter top.

Remove the four housing copper colored wire brads from the structural foam housing by carefully pulling them out of the housing. The housing lifts off the console top. Unscrew the four sheet metal screws holding the perforated steel bottom cover to the counter top. Save all keyboard parts and mounting hardware.

6. Attach the console top with the mounted ball to the console weldment with the six, 3/8 inch diameter bolts which held the original counter top.

**NOTE:** Make sure that the floppy disk housing (if present) is in place before tightening the two bolts which hold it to the weldment.

7. Set the EMKI jumper settings as shown in **MCS ENHANCED KEYBOARD INTERFACE CARD (EMKI)** in section 3 of this manual.

8. Install the keyboard in the counter top. Mount the perforated shell cover first and then the structural foam housing. Ensure that the trackball connecting cable is inside the perforated cover before tightening the cover screws. Mount the structural foam housing with the brads. Mount the keyboard assembly to the structural foam housing. Connect the power, RS-232, ADS, relay, and trackball cables before the electronics are installed.



---

---

## SECTION 5 – MAINTENANCE

MCS maintenance involves troubleshooting and replacement of failed parts. Printed circuit boards should not be repaired in the field. Those containing MOS devices should be placed in anti-static bags when stored or shipped back to the factory. All repair and adjustment should be performed by qualified personnel.

This section covers preventive maintenance, diagnostic tests and replacement part procedures. Information in Sections 2 through 4 may also help in replacing parts. The **Installation** and **Start-Up** section should be carefully reviewed for specific adjustments associated with certain replaceable parts, before the system is returned to normal operation.

### Preventive Maintenance

MCS Component	Frequency	
	Monthly	Annually
Floppy Disk Drive	---	Clean, inspect, and check alignment.
Printer	Inspect, Clean, and Lubricate.	Adjust.
Keyboard Electronics, Power Supply Adjust	---	Check power. Adjust power supply if necessary.
Blower Assembly	Clean Filter.	Rinse filter with water, blow dry, and reinstall. Remove squirrel cage and oil bell at motor axis.
Power Supplies	---	Check and adjust power supply, if necessary.
Touch Screen and CRT Setup	---	Inspect and check alignment.

The MCS arrives ready for operation. After completing the instructions given in Section 2, the unit should be prepared for service. Should

you encounter trouble, this troubleshooting guide may help you identify the problem and fix it.

Symptom	Possible Problem or Solution
No power indicator on circuit	no AC power at MCS blown fuse on AC input module check AC wiring on input module check breaker wiring check AC input module check breaker light
Breaker off but indicator on	check breaker contacts check breaker wiring check AC input wiring
No green indicator (LED) on CPU card	check power at supply(s) check ripple at supply(s) check fuses check power at backplane check CPU Card LED check all CPU card jumpers check reset line and PFI check reset switch (faulty?) check remaining card jumpers check ROMs check CPU to Memory card cable(s) pull out cards one by one - start with matrox, then serial, third RAM memory card, etc.
Green LED comes on but goes off quickly	check all power points as before check all switch and jumper settings for all cards check SASI - OMTI - Hard Disk Drive - Floppy Disk Drive combination including all cables
No prompt or disk I/O or time out	check SASI - OMTI etc. as above check clock calendar module check terminal settings check CPU/Terminal cable - S-232 drivers (1488, 1489)
Improper/Incomplete Start-up	see diagnostic message at start-up for possible problems if parity light on global memory cards stays on, check card jumper settings; if persists, replace global memory card; if persists, check CPU#1 jumper settings; if persists, replace CPU#1.
Start-up OK but no CIU response	check CIU settings (checksum on port A at 19.2 Kbyte) check CIU cables check serial I/O Card jumpers try using CIU diagnostic port to test CIU/LSM/BTM Modules

Symptom	Possible Problem or Solution
<p>Start-up OK but no keyboard response</p>	<p>check serial I/O Card and jumpers                      check all cables                      check keyboard power (incl. ripple)                      check caps lock position                      check MCS configuration (# keyboards?)                      check keyboard assignment                      may have defined the keyboard controller card to be an EMKI when it is actually an MKI or vice-versa. Run the keyboard conversion program EXTCON.OB. Refer to the appropriate EN for the MCS software revision in use.</p>
<p>Start-up OK no CRT picture</p>	<p>check CRT AC power                      check CRT fuses                      check RGB cables                      check matrox cards                      check MCS Conf. (# CRTs ?) - in file SYSTSIZE.CF and MCS Sector 0 (CF)</p>
<p>No printer response</p>	<p>check AC power                      check serial I/O card(s)                      check cables                      check printer set-up                      check MCS configuration (# ?)                      check printer directories (logging) for corruption</p>
<p>No cursor response with trackball</p>	<p>Check the trackball cable by substitution.</p>

## Power-Up Tests

If the troubleshooting guide fails to identify a problem, proceed with the following step-by-step procedure.

### Power-Up Tests AC Power

1. Disconnect AC power to all equipment inside the MCS console by unplugging all line cords from the AC distribution board.
2. Apply power to the MCS by switching on the line circuit breaker located at the front of the MCS (Figure 5-1).

**NOTE:** For the remainder of this manual, when the instructions state to apply power to the MCS, that will mean switching the main circuit breaker to the ON position. Likewise, when told to turn off the power to the MCS, that will mean switching the main circuit breaker to the OFF position.

3. Using a digital voltmeter, measure the AC power at each of the outlets (J1 through J8). The line voltage should be 102-132 V ac RMS.

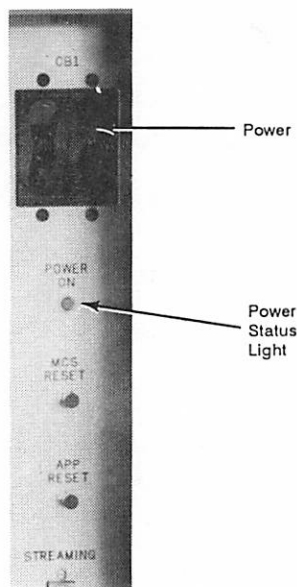

Figure 5-1. Apply Power to the MCS with the Main Circuit Breaker (CB1)

® Wyse is a registered trademark of Wyse Technology  
® Tektronix is a registered trademark of Tektronix Inc.

## TROUBLESHOOTING

4. Using the digital voltmeter, check each outlet to insure that neutral, live, and ground are wired correctly, and there are no ground faults.
5. Turn off the power to the MCS. Verify that it removes power from all outlets.
6. Plug the blower and the color monitor power cords into the appropriate AC Distribution Board sockets. **DO NOT** plug in the DC power supplies yet. Apply power to the MCS. Verify that the blower is operational. Nothing will be displayed on the color monitor until the system software is loaded.

### DC Power

1. Turn off power to the MCS. Unplug all NETWORK 90 modules from the Module Mounting Unit (MMU).

Necessary test equipment:

- 1 - Digital Voltmeter
- 1 or 2 - Wyse® 50 Terminals, ADM-3 (or equivalent) Terminals
- 2 - RS-232 cables (25 pin male to male, wired one-to-one)
- 1 - SBE Serial Port Cable (1948200\_50N14)

The following equipment is optional depending upon the terminal used and tests run:

- 1 - RS-232 cable set up as a **null modem**
- 1 - RS-232 Loop-Back Plug
- 1 - Oscilloscope - Tektronix® 475 or equivalent

2. Unplug DC power distribution cables from all peripheral devices (disk drives, disk drive controller card, keyboard, reset board, and touch screen controller, if present). On MCS consoles having two DC power distribution panels, disconnect the power cables at the distribution side of the cables. For MCS consoles

with one DC power distribution power panel, cables must be disconnected at the peripheral device end of the cable.

NOTE: Do NOT disconnect the power wiring from the NETWORK 90 MMU and the Multibus card cage.

3. Unplug all Multibus cards from the Card Cage.

NOTE: The modules and cards do not have to be pulled all the way out. They just need to be disconnected and pulled a few inches away from the card edge connectors.

4. Plug the power line cord for the 750 Watt power supply into the AC distribution panel.

5. Ensure that ALL Power Supply Wiring is correct.

6. Apply power to the MCS.

7. Measure the DC voltages at the Multibus Card Cage.

8. Verify the DC voltages at the power supply (Figure 5-2). DO NOT attempt to adjust the OL and OVP settings. These are factory set.

Adjust the voltages to within a tolerance of approximately  $\pm 0.25$  V of the following values, if necessary. A final adjustment will be made later with the power supply under load. Refer to Figure 5-2.

- +5.00 V dc at the CH1 positive terminal
- +12.00 V dc at the CH2 + terminal
- 12.00 V dc at the CH3 - terminal
- +15 V dc at pin 7 of J2 (to within  $\pm 0.5$ V)
- 15 V dc at pin 9 of J2 (to within  $\pm 0.5$ V)

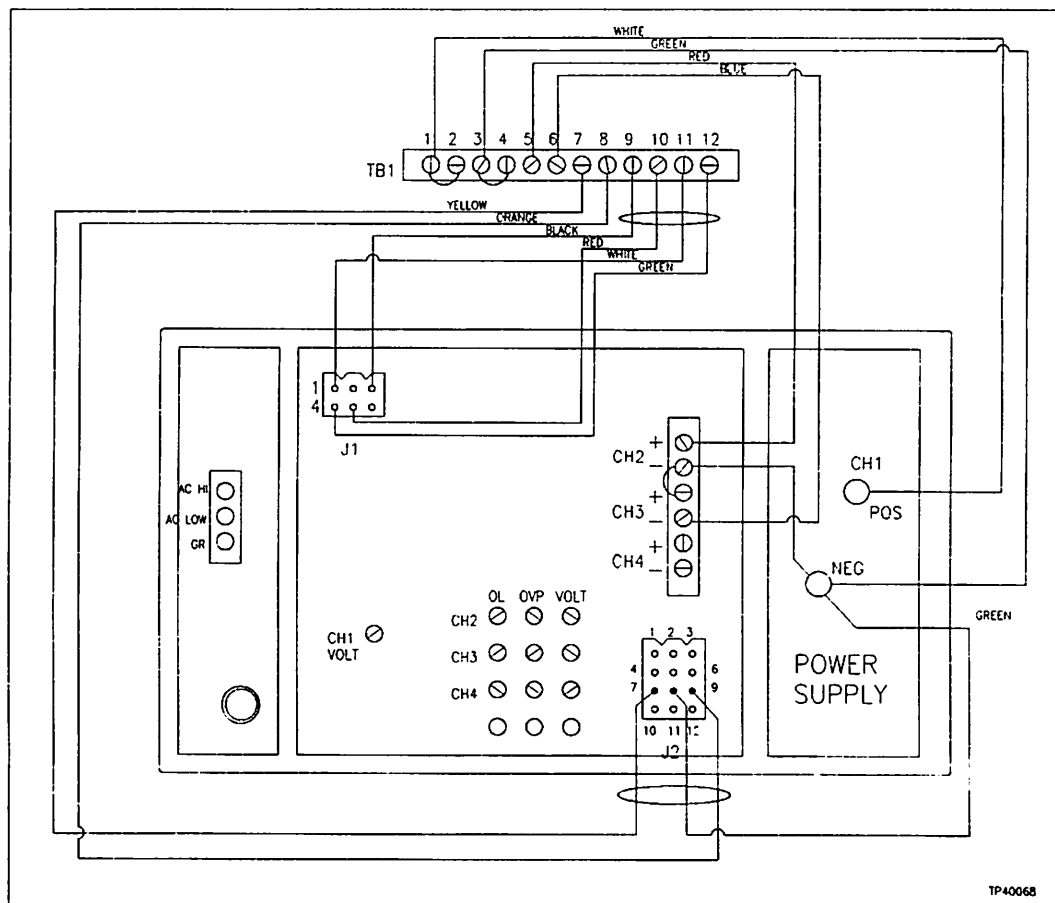

Figure 5-2. Wiring Schematic for Main Power Supply

---

## Power-up Tests

## TROUBLESHOOTING

9. Turn off the power to the MCS. Plug in all Multibus cards and MMU modules.
10. Reconnect all DC power distribution cables.
11. Apply power to the MCS and check the DC voltage levels again. Adjust the power supply as necessary to obtain the voltage within a tolerance of  $\pm 0.05$  V.

13. With the MCS power still on, check the level of the  $\pm 15$  V source at the MMU. Adjust the power supply as necessary to within  $\pm 0.5$  V.

NOTE: Verify that  $\pm 5$  V is also connected to the MMU, but DO NOT readjust. Only verify that it is present.

---

---

## TROUBLESHOOTING

This section consists of running a set of software-driven tests to confirm that each card or subassembly within an MCS works by itself. The sequence of testing is structured to first prove that lower level parts work, then use these parts to test the rest of the system. The tests assume that the technician has verified power wiring, DC power levels and the routing and connection of all cables.

The equipment necessary for these tests is:

- a dumb terminal (Wyse 50 or ADM-3)  
P/N: NTER01
- a 9-pin RS-232-C cable (25 pin D male to male) P/N: NKMR01-25
- a null RS-232-C cable (9-pins with pins 2 and 3 crossed over) P/N: HCBL02
- a 50-pin SBE-CPU port cable  
P/N: 1948200\_50N14

Initial setup:

Equipment setup for the testing of the Multibus cards:

**NOTE:** When a dumb terminal is connected to a CPU, it will be referred to as a Monitor-68K terminal.

1. Connect a Monitor-68K Terminal to the MCS processor (M68CPU/MEM) card set (slots 15/16 and 18/17) and to the Disk Server (slots 12/11). These cards are located in the Multibus card cage. At the present time only the first card set is of concern. The remaining cards will be tested later.
2. Using a standard 9-conductor RS-232-C cable with 25 pin D male connectors on each end, connect one end to the modem port of the terminal.
3. Connect the other end to the channel A port on the CPU diagnostic connector cable (a 50-pin ribbon cable). This cable, in turn, should be plugged into a connector at the bottom of the M68-CPU card. For this test, start by plugging the cable into the M68CPU card located in slot number 18.

## Multibus Card and Subassembly Tests

**NOTE:** Test sections must be repeated for each additional CPU card or card set. The Monitor-68K terminal must be connected to the CPU card set being tested.

1. Test MCS CPU/MEM 1. Connect the Monitor-68K terminal to the lower connector on the MCS CPU card (slot 18). Apply power to the MCS.
2. Enter the Monitor mode by pressing <Return> on the terminal within seven seconds after applying power to the MCS, otherwise the operating system will load. If this time frame is passed, reset the MCS and re-try.

After entering the monitor mode, the screen shows a new line and a prompt 1:>.

3. Now type PT and press the ENTER key. This runs the processor self test. This is not a conclusive test of all features of the Memory/CPU card pair.

If this test is successful, the monitor shows a new line and a prompt (in about one second).

If the test fails, the monitor may become unresponsive, display a memory register dump (a string of alphanumeric characters appearing on the screen), or display the message, CPU ERROR. If the test fails, try checking all switch and jumper settings on the CPU/MEM pair set or try a new CPU/MEM set. Repeat this test until the test passes.

4. This step performs a memory block test on the MEM card of the CPU/MEM pair.

Type: **BT 1500 1FFFFE**  
Press the ENTER key.

Wait for a prompt or an error message. If you get an error message, replace the MEM board and repeat steps three and four.

If successful, this test returns a prompt (in about 18 seconds). When the prompt returns, you are ready to continue.

5. **Test MCS CPU/MEM 2.** Connect the Monitor-68K terminal to the lower connector on the MCS CPU card (slot 15).

6. Perform steps three and four of this procedure.

7. **Test MCS Disk Server/MEM.** Connect the Monitor-68K terminal to the lower connector on the MCS Disk Server Card (slot 12).

8. Perform steps three and four of this procedure.

9. **Test Global Memory Card 1.** Connect the Monitor-68K terminal to the lower connector on the MCS CPU #1 (slot 18). Press the ENTER key on the terminal. You will get a prompt on the screen.

NOTE: Since the switch settings differ on these cards, they are NOT interchangeable.

Type: **BT 800000 9FFFFE**  
Press the ENTER key.

10. Wait for a prompt or an error message. With an error, check all switch and jumper settings on the global RAM cards and/or try new global RAM cards.

If the test is successful, the monitor will show a new line and/or a prompt (in about 20 seconds). When a prompt or new line returns, you are ready continue.

11. **Test Global Memory Card 2.** Connect the Monitor-68K terminal to the lower connector on the MCS CPU #1 (slot 18). Press the ENTER key on the terminal. You will get a prompt on the screen.

Type: **BT A00000 BFFFFE**  
Press the ENTER key.

12. **Test Global Memory Card 3.** Connect the Monitor-68K terminal to the lower connector on the MCS CPU #1 (slot 18). Press the

ENTER key on the terminal. You will get a prompt on the screen.

Type: **BT C00000 DFFFFF**  
Press the Enter key.

13. **Test Color Graphics Controller 1.** Connect the Monitor-68K terminal to the lower connector on the MCS CPU #1 (slot 18). Press the ENTER key on the terminal. You will get a prompt on the screen.

NOTE: Since the switch settings differ on these cards, they are NOT interchangeable.

Type: **SM.B FE0000 0B**  
Press the ENTER key.

or

Type: **VT 0**

The monitor should display a **VERIFY ERROR AT** message if you use the **SM.B FE0000 0B** test method. This is not a problem at this time. Within about six to seven seconds, the MCS monitor will display a series of blue, then green stripes.

14. Self test status - Color Graphics Controller 1.

During and/or after completion of the self test, the status of the graphics controller card may be checked.

NOTE: If you used VT in Step 13, the status is automatically checked.

Type: **DM FE0000**  
Press the ENTER key.

The monitor shows one of the two character codes listed in Table 5-1. If the code **1B**, appears a second time, repeat Steps 9 and 10 after checking jumpers and wire wraps of each graphics controller card.



Table 5-1. Graphics Controller Card Self-Test Status

Code	Meaning	Action
10 11	Illegal command Stack overflow	Reset MCS and retry test
12 13	Stack underflow Selftest OK	Test complete, continue with step 15
14 15	Program error Circular buffer full	Reset MCS and retry test
16 17	Reset completed Illegal tracking command	Retry test
18 19	Illegal inking command Illegal rubberband command	Reset MCS and retry test
1A 1B	Doing selftest Selftest fail	Test in progress Retry test
1C	CPU timeout	Reset MCS and retry test

## 15. Test Color Graphics Controller 2, 3, and 4.

First method:	
Second Card:	Type: SM.B FE0001 0B Press the ENTER key.
Third Card:	Type: SM.B FE0002 0B Press the ENTER key.
Fourth Card:	Type: SM.B FE0003 0B Press the ENTER key.
Second method:	
Second Card:	Type: VT 1
Third Card:	Type: VT 2
Fourth Card:	Type: VT 3
Self-Test Status - Color Graphics Controller 2, 3, and 4.	
Second Card:	Type: DM FE0001. Press the ENTER key.
Third Card:	Type: DM FE0002. Press the ENTER key.
Fourth Card:	Type: DM FE0003. Press the ENTER key.

16. **Test Serial I/O Interface Cards 1 and 2.** Connect the Monitor-68K terminal to the lower connector on the MCS CPU #1 (slot 18). Press the ENTER key on the terminal. You will get a prompt on the screen.

17. Check for the presence of a serial interface card by looking at memory locations in the area of each port (about 256 bytes of memory is sufficient). Ability to access all ports shows that the serial interface card is properly addressed. The test procedure for the serial interface card is given in the following two steps.

18. For First Card:  
Press the ENTER key.  
(Monitor displays a prompt.)

Type: **DM FA0000** {for port 0}  
Press the ENTER key.

Type: **DM FA2000** {for port 1}  
Press the ENTER key.

Type: **DM FA4000** {for port 2}  
Press the ENTER key.

Type: **DM FA6000** {for port 3}  
Press the ENTER key.

Type: **DM FA8000** {for port 4}  
Press the ENTER key.

Type: **DM FAA000** {for port 5}  
Press the ENTER key.

Type: **DM FAC000** {for port 6}  
Press the ENTER key.

Type: **DM FAE000** {for port 7}  
Press the ENTER key.

19. For Second Card:  
Press the ENTER key.  
[Monitor displays a prompt.]

Type: **DM FB0000** {for port 0}  
Press the ENTER key.

Type: **DM FB2000** {for port 1}  
Press the ENTER key.

Type: **DM FB4000** {for port 2}  
Press the ENTER key.

Type: **DM FB6000** {for port 3}  
Press the ENTER key.

Type: **DM FB8000** {for port 4}  
Press the ENTER key.

Type: **DM FBA000** {for port 5}  
Press the ENTER key.

Type: **DM FBC000** {for port 6}  
Press the ENTER key.

Type: **DM FBE000** {for port 7}  
Press the ENTER key.

20. **Test Disk System Functions.** This non-destructive test returns a prompt if successful. If the test fails, one of the two character codes listed in Table 5-2 displays on the monitor screen.

## TROUBLESHOOTING

## Multibus Card and Subassembly Tests

Table 5-2. Disk Read Test Error Codes

Code	Meaning
02	read error on the hard disk
22	read error on floppy disk
FF	data error on disk(s) time out error on disk I/O
1F	system (bus controller, disk controller, or either disk drive)
volume not initialized	directory volume not established yet (This is not a problem at this time.)

21. **Disk Sector tests.** Press the ENTER key. [Monitor displays a prompt.]

Type: **DT 0** [Hard disk sector 0 test.]  
Press the ENTER key.

22. Insert a floppy disk into the floppy disk drive.

Type: **DT 1** [Floppy disk sector 0 test.]  
Press the ENTER key.

On the success of the tests in Steps 21 and 22, the monitor displays a prompt. An error displays: **DISK I/O ERROR \_\_\_**. Note the error message that is shown and reset the MCS. Press the ENTER key; repeat Steps 21 and 22.

23. **Directory Reads.** Further verify disk system operation by listing the directory for each disk device.

Press the ENTER key. [Monitor displays a prompt.]

Type: **DI 0** [Hard disk drive directory.]  
Press the ENTER key.

Insert **SYS1** disk into the floppy disk drive.

Type: **DI 1** [Floppy disk drive directory.]  
Press the ENTER key.

On success of this test, the monitor displays a directory listing, one screen at a time. If this test fails, the monitor displays the same error messages as in Step 20. Note the error, reset the MCS, press the ENTER key, and repeat the directory read tests.

## DIAGNOSTICS IN EPROM

The MCS supports diagnostic system tests run with a terminal. The tests are located in the EPROM on the MCS CPU 1, MCS CPU 2, and Disk Server CPU cards. The key functions listed in Table 5-3 are control commands which may be used during these tests.

Commands can also be chained together. For example:

Entering: CT;RC;CT

Causes the following to be printed:

05/15/87 10:38:24 current date and time

u19 u27 ROM checksum  
116E 3DCA

05/15/87 10:38:25 current date and time

Chaining the clock test command with other tests provides a timer. You can also chain single tests together.

Table 5-3. Control Commands for Advanced Diagnostics

Function	Purpose
ESCAPE	Exits advanced diagnostics and returns to monitor level program
CTRL-A	Aborts current test
CTRL-C	Copies successive characters of previous input line
CTRL-R	Reprints previous command input line
CTRL-S	Suspends current test, hit any key to continue
/R	Repeats the test until error or you abort the test (CTRL-A)
;	Separates a sequence of tests
\	Continues command inputs onto next line
[...]	Indicates optional parameters

---

---

## DIAGNOSTICS IN EPROM

To run the ROM based diagnostics, connect a terminal to the diagnostic port of the desired CPU card, then press the MCS reset button. The message:

```
SYSTEM RESTARTED
ENTER MONITOR BY PRESSING <RETURN>
OTHERWISE MTOS WILL AUTOLOAD IN 7 SECONDS.
```

will be displayed on the terminal screen. Press the enter key within seven seconds to load the ROM based diagnostics. After approximately 20 seconds, a prompt will appear on the terminal:

- 1: if connected to the MCS CPU 1.
- 2: if connected to the MCS CPU 2.
- > if connected to the MCS Disk Server.

### Command Syntax

All commands consists of a two character command and a series of operands. The operands may be optional. If an operand is enclosed in <.>, it is required, and if enclosed in [..], it is optional.

### Mode

The mode states where the command can be executed. The mode the terminal begins in is

the Monitor mode. Commands which may be executed in this mode have Monitor written in the Mode column.

Advanced Diagnostic commands may be executed in DG mode. This mode is entered by typing DG in Monitor mode and pressing Enter. Pressing the Escape key will exit the DG mode and return to Monitor mode.

### CPU1, CPU2, DSV

The diagnostics reside in three CPU boards in the MCS:

CPU1 = MCS CPU 1

CPU2 = MCS CPU 2

DSV = MCS Disk Server

The terminal must be connected to the diagnostic port of the proper CPU card. Each command states which CPU card it is available on. Some commands are available on more than one CPU card.

Diagnostic Commands

DIAGNOSTICS IN EPROM

Command Syntax	Mode	CPU1	CPU2	DSV	Description
BT <start addr> <end addr>	DG	X	X	X	Read/write test of Continues segment of Memory.
BU				X	Load streaming tape from hard disk.
CF	Monitor	X		X	<p>Configure system hardware. A menu comes up on the terminal with these options:</p> <p>A - System to be configured with no Application Processor.</p> <p>B - System to be configured with an Application Processor.</p> <p>1 - Configure MCS Host.</p> <p>2 - Configure Application Processor Host.</p> <p>E - Exit.</p> <p>If item A or B is selected, for the host configuration.</p> <p>If item 1 or 2 is selected, the user is prompted for each LUN, number of request buffers, host base address, physical device number start address of device, and byte length of device. If RETURN is entered for any of these prompts, the default values displayed in brackets will be used.</p> <p>All default values are zero. The defaults are left to zero, and the host configuration is updated to disk, the MCS will be unable to see some or all connect the terminal to the disk server unit and restart the CF command.</p>
CI	DG	X			CIU test.
CL	DG	X	X	X	Clear configuration and re-start diagnostics.
CM <addr1> <length> <addr2>	Monitor	X		X	Compare two blocks of memory.
CT <[month/day/year] hour:minute>	DG	X			Clock test.
CV <decimal num> or CV 0<hex num>	Monitor	X	X	X	Convert decimal and hexadecimal integers.
D!	Monitor			X	Starts disk server processing with debug messages enabled. When debug messages are enabled, output and performance is slowed.

DIAGNOSTICS IN EPROM

Diagnostic Commands

Command Syntax	Mode	CPU1	CPU2	DSV	Description
DS	Monitor			X	Starts disk server processing with debug messages disabled; equivalent to normal auto-start.
DF	Monitor	X			Duplicate floppy. User is prompted for input.
DG	Monitor	X	X	X	Start Bailey MCS EPROM-based advanced diagnostic utilities.
DI <drive num> [USN]	Monitor	X		X	Directory listing of files for specified device and USN. The hard disk is drive number 0, and the floppy disk is drive number 1.
DM [<addr> [num of bytes]]	Monitor	X	X	X	Display memory starting at specified location.  DM Display next 16 bytes.  DM <address> Display next 16 bytes at starting address.  DM <address> <num of bytes> Display next <num of bytes> at starting address.
DP <device>	DG			X	Disk parameters.
DS	Monitor	X			Dismount disk; flush disk buffers.
DT <drive #>	Monitor	X			Easy disk read test for sector 00.
EL	DG			X	Error log for hard disk.
FO <device> [type]	Monitor	X	X	X	Format specified file system device. This command formats either floppy disks or the hard disk. The optional type parameter is used to format the hard disk and is either a 1 (model V150, D550) or a 2 (model V185). If the type parameter is needed but not present on the command line, the user is prompted for it.  When the system is done formatting the hard disk, it enters RT (replace track_ mode, and asks for the cylinder address and the head address (in decimal). It then assigns an Alternate Track table and informs when it is complete. To exit, press return with no input to the head or cylinder field. The system then returns to the CFG mode. Upon completion of the CF command, the system returns to the command line prompt.

## Diagnostic Commands

## DIAGNOSTICS IN EPROM

Command Syntax	Mode	CPU1	CPU2	DSV	Description
GO [<addr>] or GO [/till <addr>]	Monitor	X	X	X	Starts execution of a program.
GT <board [test]>	DG		X		Graphics test. <board> = 0 to 3, [test] = 1 to 5.
HE [command name]	ALL	X	X	X	Help displays information, parameters, etc. for a selected command or all commands.
HT	Monitor	X	X	X	Causes monitor to enter host transparent mode.
IT	DG	X	X	X	Interrupt test.
KK <keyboard #>	DG	X			Keyboard key test.
KL <keyboard #>	DG	X			Keyboard LED test.
KR <keyboard # [relay mask]>	DG	X			Keyboard relays test.
KS <keyboard #>	DG	X			Keyboard sound test.
LF <addr> <filename.ex> <drive> [USN]	Monitor	X		X	Loads file under specified drive/USN into memory.
LO <addr> <num sectors> <start sector> <drive>	Monitor	X		X	Load contiguous memory image to disk.
LT <pcu #> <loop #>	DG	X			Loop test.
MB <source addr><destination addr> <num sectors>	Monitor	X	X	X	Move sectors memory (256 bytes each).
MT	Monitor	X	X		Invokes start-up or restart of MTOS operating system.
MV <source addr> <length> <destination addr>	Monitor	X	X	X	Move blocks of memory.
PT	Monitor	X	X	X	Motorola processor test.
PU <start addr> <length>	Monitor	X	X	X	Download (punch) Motorola s records to host computer.
RC	DG	X	X	X	ROM checksum.
RE	Monitor	X	X	X	Upload (read) Motorola s records from host computer.
RM <start addr> <end addr>	DG	X	X	X	Long memory test.
RS <device>	Monitor			X	Request Sense Error message from Disk Controller for given file system device. This command returns 4 bytes of sense information, in hex format, for either the floppy or hard disk.



# DIAGNOSTICS IN EPROM

# Diagnostic Commands

Command Syntax	Mode	CPU1	CPU2	DSV	Description
RT <drive> <bad track addr> <alt track addr>	Monitor			X	Performs alternative mapping (replacement of tracks) around known bad tracks on hard disk. This command prompts the user for bad cylinder and head address (must be entered in decimal format). It then automatically assigns an alternate track, prompts the user for the next bad cylinder address. If RETURN is entered alone for either prompt, RT exits back to the command line.
RU				X	Restore hard disk from streaming tape.
SA <addr> <num sectors> <start sector> <drive>	Monitor	X		X	Save contiguous image to disk.
SB <board #> <port #> [C]	DG	X			Serial Board Test. [C] = use loop-back connector.
SC	DG			X	SASI/OMTI disk controller test.
SF <addr> <filename.ex> <device> [USN]	Monitor	X		X	Saves memory data to file under specified device/USN.
SM [size] <addr> <data>	Monitor	X	X	X	Store values at memory locations. Mode can be changed to one of the following:  .B bitwise storage (8 bits) default  .W word size storage (16 bits)  .L long word storage (32 bits)
ST	DG			X	SASI interface adapter test.
SX <long word> or SY <long word> or DSZ <long word>	ALL	X	X	X	Three base registers that can be used in expressions or commands. Example:  SX 1000 SY X+2 SZ 'ABCD'
TD	Monitor	X	X	X	Trace Display. Prints the current values of all processor user registers: PC, SR, USP, SSP, D0 to D7, A0 to A7.
UT	Monitor	X	X	X	Utility that automates verification of operation for inter-processor communication hardware. Prompts user for actions. Must reset MCS at end of test.

Diagnostic Commands

DIAGNOSTICS IN EPROM

Command Syntax	Mode	CPU1	CPU2	DSV	Description
VT <device #>	Monitor	X	X	X	Call graphics controller self-test. The device # is either 0, 1, 2, or 3 for the graphics controller 1, 2, 3, or 4 respectively.
WT <device> <disk type> <# tests> <test type> [A] <i>WT 0 3 3 NA</i>	DG			X	Winchester test. Tests the hard disk.  <device> = 0 (hard disk)  <disk type> = 1 (model V150), 2 (model D550 or V185)  <# tests> = number of times to perform the test  <test type> = D - destructive; N - non destructive  [A] = replace with alternate.  NOTE; The destructive test type deletes the data on the hard disk. The user should backup data on floppies before performing this test. Upon completion of this test, perform the CF (configure) command, initialize the MCS, then reload from backups.

DIAGNOSTICS IN EPROM

File System Error Codes

Hexadecimal Error Code	Error Description
\$00	No error
\$01	Logical/physical end of file violation
\$02	Time-out occurred before initiating service
\$03	Device reported hard error in data block
\$04	Device reported hard error in File Allocation Block (FAB)
\$05	Device reported error in directory, bit-map, or volume ID sectors
\$06	Device type not compatible with this command
\$07	Device reported time-out error
\$08	Invalid command
\$09	Invalid logical unit
\$0A	No file channels available
\$0B	No units are available
\$0C	Logical unit not assigned
\$0D	File has been reserved against request
\$0E	Device has been reserved against request
\$0F	Invalid option
\$10	Incompatible option
\$11	Invalid file description
\$12	Attempt to create a file that already exists
\$13	File not found
\$14	Device not found in DIT table
\$15	Attempt to write to a file opened for read or vice versa
\$16	Error in logical record format
\$17	Invalid record format
\$18	Invalid key
\$19	Key length error
\$1A	Insufficient medium space (device full)
\$1B	Insufficient buffer space
\$1C	End of directory
\$1D	Key not found
\$1E	Key already exists
\$1F	Buffer overflow
\$20	Mount violation
\$21	Invalid volume dismount
\$22	Attempt to open or dismount while a file is open
\$23	Open files on volume
\$24	Attempt to free a channel with pending requests
\$25	Unit has been reserved so open files can be aborted
\$26	Internal error
\$27	File must be reserved
\$28	Unit must be reserved
\$29	Invalid time unit for PAUFIN coordination
\$2A	Illegal coordination mode given
\$2B	Size conflict during write
\$2C	Variable length record length of 0
\$2D	Inconsistent lock option
\$2E	Attempt to close while no file is open
\$2F	No internal queue block available
\$30	Mismatch of label or sequence number

**File System Error Codes**

**DIAGNOSTICS IN EPROM**

Hexadecimal Error Code	Error Description
\$41 \$42 \$43 \$44 \$45 \$46 \$47 \$48	Device error (hard error) Disk controller error Seek error Write error Exclusive device access denied Can not open device Illegal operation code Illegal request
\$49 \$4A \$4B \$4C \$4D \$4F \$50 \$51	Time out error - for MCS time out of request I/O routine Bad lun number Illegal disk address Illegal memory address No lun for host Reset command successfully completed Hash overflow buffer is full Write protection error
\$5F \$60 \$61 \$62 \$63 \$64 \$65	Disk controller time out Check condition (sense bytes returned in sense data buffer) Signal that host issuing a close never had exclusive access Unit is off-line Interface device (SCSI board) not present or functioning A track on a device was not formatted completely An unexpected SASI PIO status was returned
\$101 \$102 \$103 \$104 \$105 \$106 \$107	The maximum number of files is open The requested record length is too big for UNIX buffers Invalid pathname format Invalid type supplied Asked for sequential file, file is contiguous Requested sequential record size is different from existing file Attempt to append at end of contiguous file

DIAGNOSTICS IN EPROM

Disk Controller Error Codes

Hexadecimal Error Code	Error Description
\$0000	No error
\$0100	No index signal
\$0200	No seek complete
\$0300	Write fault
\$0400	Drive not ready
\$0500	Drive not selected
\$0600	No track zero found
\$0700	Multiple drives selected
\$0900	Cartridge changed
\$0D00	Operation in progress
\$1000	Tape exception
\$1100	Uncorrectable error in data field
\$1300	No address mark in data field
\$1400	No record found
\$1500	Seek error
\$1700	Write protected
\$1800	Correctable ECC error
\$1900	Bad track flag set
\$1A00	Incorrect interleave factor
\$1C00	Unable to read alternate track data
\$1E00	Illegal direct access to alternate track
\$1F00	Tape drive failure
\$2000	Invalid command
\$2100	Illegal parameters
\$2200	Illegal function for drive type
\$2300	Volume overflow
\$3000	Power up diagnostic error
\$3100	FDC 765 error
\$9100	Uncorrectable error in data field
\$9300	No address mark in data field
\$9400	No record found
\$9500	Seek error
\$9700	Write protected
\$9800	Correctable ECC error
\$9900	Bad track flag set
\$9A00	Incorrect interleave factor
\$9C00	Unable to read alternate track data
\$9E00	Illegal direct access to alternate track

Hexadecimal Error Code	Error Description
\$01	Modified buffer could not be written
\$02	Could not close file
\$04	Could not dismount file
\$08	Could not close file because End Of Tape was encountered
\$101	The maximum number of files are open
\$102	The requested length is to big for UNIX
\$103	Invalid pathname format
\$104	Invalid type supplied
\$105	Asked for sequential, file is contiguous
\$106	Requested sequential record size is different from existing file
\$107	Attempt to append to a contiguous file at end of file

**DIAGNOSTICS IN EPROM**

**Tape File Error Codes**

Hexadecimal Error Code	Error Description
\$201	Attempt to mount or init while volume is mounted
\$202	Attempt to dismount or open while no volume is mounted
\$203	Attempt to init volume with invalid bpi density
\$204	Attempt to dismount when task hadn't mounted
\$205	End Of Tape (EOT) encountered before operation was completed
\$206	Tape file system internal error
\$207	Device busy - can not perform mount or open
\$208	Volume is write protected
\$209	Size of file created does not match the original create file parameter, file will be deleted on close.
\$20A	(for internal use)
\$20B	(for internal use)
\$20C	EOV mark exists, no recovery action taken
\$20D	Directory full, reached maximum number of files
\$280	Unexpected sense data format
\$281	Target managed to recover an error condition
\$282	Unit not ready
\$283	Command terminated due to flaw in medium or error in recorded data
\$284	Target detected non-recoverable hardware error
\$285	Illegal request
\$286	Unit attention, medium may have been changed
\$287	Data protect
\$288	Blank check, reading blank block
\$289	Incorrect block length

CIU Error Codes

DIAGNOSTICS IN EPROM

Below are CIU error codes in decimal format. See Bailey Product Instruction E93-905-9, Enhanced Computer Interface Unit

Programmer's Reference Manual, for further information.

Decimal Error Code	Error Description
0	No error
1	Waiting for loop
2	Improper format
3	Illegal command
4	Index already established
5	Block already established at another index (Loop, PCU, MOD, and Block are all the same as another tag)
6	Command too long
7	Bad reply from LIS/BTM
8	Export used as Import
9	Repeat CIU restart command
10	Undefined index
11	Memory full
12	Host communication error
13	LIS/BTM not responding
14	Import used as Export
15	Time-out of loop response
16	Number out of range
17	Illegal key
18	Need a restart command
19	Module status used as Import
20	Message active on loop
21	Import or Export used as module status
22	Exception report specifications lost
23	No message queued, dequeue received
24	Reply too large
25	Illegal station mode command
26	Illegal module number in command
27	Time out between bytes in command
28	Index already established by another node
29	Point type incompatible with command
30	Watchdog time-out
31	Checksum compare error
32	Destination node off-line
33	Callup command required
34	CIU error
35	CIU busy
36	LIS/BTM off-line
37	Conflict with monitor mode
38	Point type incorrect
39	Destination ring off_line
40	Destination node busy
41	Destination ring busy



Decimal Error Code	Error Description
100 101 102 103	Undefined message type for target module Busy - cannot respond at this time Mode for command does not agree with current module mode Message data out of range
104 105 106 107	Invalid block number Undefined block number - block is valid but not configured Block not readable - block number is valid but has no readable parameters Invalid function code for target module
108 109 110	Function code and block number not compatible in target module Insufficient memory to write block in EEROM and/or RAM Module not responding

---

---

## PART REPLACEMENT PROCEDURES

### Card Cage

Bailey P/N 1948017\_1

1. Disconnect all cables and wiring from the back of cage.
2. Remove the four screws at the front of the card cage (two on each side).
3. Slide the cage out of the cabinet.

### Color Monitor

Bailey P/N - 6636994\_1

1. Shut off power to the MCS.
2. Remove the two screws at the side of the door which retain the top cover. Remove the top cover by lifting the rear edge and pushing toward the front of the MCS.
3. Remove the cable from the J1 connector.
4. Remove the cable to the front panel mounted brightness control.
5. Remove the power cord.
6. Remove the two screws holding the CRT to the rails.
7. Slide the CRT out the rear of the MCS.

### Disk Drive Controller Card

Bailey P/N - 1948013\_1

1. Shut off power to the MCS.
2. Disconnect the ribbon cables from the controller card.
3. Loosen the controller card attaching screws. Carefully lift off the controller card.

### Fan Assembly

Bailey P/N - 6634988\_1

Air Filter - 199914\_22

1. Shut off power to the MCS.
2. Cut and remove cable ties securing the fan assembly power cord.
3. Remove the air filter.
4. Remove the two screws at the bottom of the fan assembly which secure the unit to the MCS.
5. Remove the two screws securing the I/O Distribution Board to the top of the fan assembly.
6. Lift the unit out of the MCS cabinet.

### Floppy Disk Drive

Bailey P/N - 1948018\_1

1. Shut off power to the MCS.
2. Remove all power and ribbon cable connectors to the floppy disk drive.
3. Remove the bolt at the the bottom of the disk drive.
4. Remove the bolt at the top of the disk drive.
5. Slide the disk drive out through the front of the MCS.

---

## PART REPLACEMENT PROCEDURES

### Hard Disk Drive

Bailey P/N - 1948002\_1

1. First, remove the disk drive controller card. Use the procedure given on page 65.
2. Disconnect plugs to the Main Power Supply.
3. Loosen the right most screw (as viewed from the rear) but leave in place. Remove the four remaining screws retaining the disk power supply.
4. Swing the power supply to the right and out of the way, to gain access to the hard disk drive. Cut and remove cable ties securing AC and DC wires.
5. Disconnect all power and ribbon cables to the hard disk drive.
6. Remove the screws securing the hard disk drive to the cabinet. Lift the drive out of the cabinet.

### MCS Keyboard

Bailey P/N - 6636278\_1

1. Shut off power to the MCS.
2. Slide the NETWORK 90 Logo plate from the face of the keyboard.
3. Remove the two screws holding the keyboard assembly to the keyboard housing.
4. Lift the keyboard assembly and remove the connections at the CPU card's connectors and the keyswitch connectors.

### I/O Power Supply

Bailey P/N - 1948005\_

#### WARNING

Disconnect from electrical supply before attempting repair or replacement.

#### AVERTISSEMENT

Debrancher de la source électrique avant de procéder à des travaux de réparation ou de remplacement.

1. Shut off power to the MCS.
2. Cut and remove cable ties retaining the AC and DC wires to/from the disk power supply.
3. Release the plunger latches on the supply and slide it out of the cabinet.

### Main Power Supply

Bailey P/N - 1948003\_

1. Shut off power to the MCS.
2. Remove the power supply plug from the socket on the AC Distribution Board.
3. Mark and disconnect the wires between the power supply and the TB1 terminal block and the NTPL01 or NTCL01 Termination Unit.
4. Release the plunger latches on the Power Supply Assembly; slide the unit out of the cabinet.

---

## PART REPLACEMENT PROCEDURES

### Reset Assembly

Bailey P/N - 6636410\_1

Remove the card cage to access the reset assembly.

1. Follow the directions for removing the card cage.
2. Remove wiring connections from the reset assembly.
3. Remove the retaining screws securing the assembly to the cabinet.

### Termination Unit

Bailey P/N - NTPL01 or NTCL01

1. Shut off power to the MCS.
2. Disconnect all attached cables and wiring.
3. Remove the two retaining screws.

---

---

## SECTION 6 – SERVICE AND NEW PARTS

Bailey Controls is always ready to assist its customers in the operation and repair of its products. Requests for sales and/or application services along with installation, repair, overhaul and/or maintenance contract services should be directed to your nearest Bailey sales/service office.

### Replacement Parts and Ordering Instructions

If the user wants to make repairs at his facility, replacement parts should be ordered through a Bailey sales/service office. We request that the following information be provided when ordering parts:

1. Part description, part number, and quantity.
2. Model and serial (if applicable) number(s) and ratings of the assembly for which the part has been ordered.
3. Bailey publication number and reference used in identifying the part.

When ordering parts from Bailey, we request that part numbers and part descriptions from respective Renewal Parts sections of pertinent equipment manuals be used. Parts which do not have a commercial description provided must be ordered from your nearest Bailey sales/service office. Recommended spare parts lists, including prices, on standard assemblies are also available through your nearest Bailey sales/service office.

### Training

Bailey Controls has a modern training center, equipped to provide service and repair instruction, which is available for in-plant training of customer personnel. Specific information regarding course content and scheduling can be obtained from your nearest Bailey sales/service representative.

### Technical Documentation

Price and delivery of additional copies of this publication can be obtained through your nearest Bailey sales/service office.

Table 6-1 is a list of the recommended spare parts for the MCS. Bailey suggests a stock supply of one item each to minimize the duration and cost of down-time in case of component failure. A manual reference for each part is given to quickly locate important service or installation information.

Table 6-2 is a list of the recommended spare parts if you have the optional NMED01 Remote Electronics Cabinet. Bailey suggests one item each be maintained in your stock supply.

Table 6-3 is a list of the recommended spare parts if your MCS has the optional touch screen. Bailey suggests one item each be maintained in your stock supply.

Table 6-1. MCS Recommended Spare Parts List

Description	Part No.	Manual Location (Page Number)
Air Filter	199914-22	5-26
Bus Transfer Module	NBTM01	3-18
Cable(s): NLIM02 to NTPL01 NLIS01 to NTCL01	NKLM01/02/03/04 NKLS01	3-43 4-31
Clock Calendar Card	1947999-1	3-11
Color Graphics: Controller Card Color Monitor	1948025-1 6636994-1	3-5, 4-5 3-22, 4-6
CPU Card 1	6637033-2	3-10
CPU Card 2	6637033-3	3-10
Disk Server Card	6637033-4	3-7
Fan Assembly	6634988-1	5-26
Floppy Disk Drive	1948018-1	3-27/29, 5-26
Global Memory Card 2 MEG RAM	1948028-1	3-12
Hard Disk Drive	1948002-1	3-30/32, 5-27
Intelligent Serial Interface Card	1948021-2	3-6
Keyboard Controller: MKI EMKI	6636278-1 6637517-1	3-33 3-34
Local Memory Card	6637447-1	3-9
Loop Interface Module	NLIM02	3-17
Loop Interface Slave	NLIS01	4-31
Loop Storage Module	NLSM02	3-19
Power Supply Asseby I/O	6636374-1	3-37
Power Supply Assembly Main	6636444-1	3-39
Reset Assembly	6636410	3-42
Superloop Storage Module	NSSM01	4-32
Termination Unit: Communication Link	NTCL01	3-43

Table 6-2. NMED01 Recommended Spare Parts

Description	Part No.	Manual Location (Page Number)
Power Entry Panel	6637587-1	4-24
Termination Modules: Communication Link	NICL01	2-1

Table 6-3. Touch Screen Recommended Spare Parts

Description	Part No.	Manual Location (Page Number)
Touch Screen	1948026-1	4-33
Touch Screen Controller Card	1948027-2	4-33

---

## APPENDIX A – WIRE AND COMPONENT LOCATION

Drawings are used throughout this manual to limit possible confusion of a cluttered photograph. Drawings are able to provide just the required information necessary to configure the MCS. There are times, however, when the additional information provided by a photograph is invaluable.

The photographs in this section are intended to provide additional information concerning MCS wire and component location only. They may not contain the correct jumper and dipswitch settings. Refer to sections 3 and 4 of this manual for jumper and dipswitch configuration.

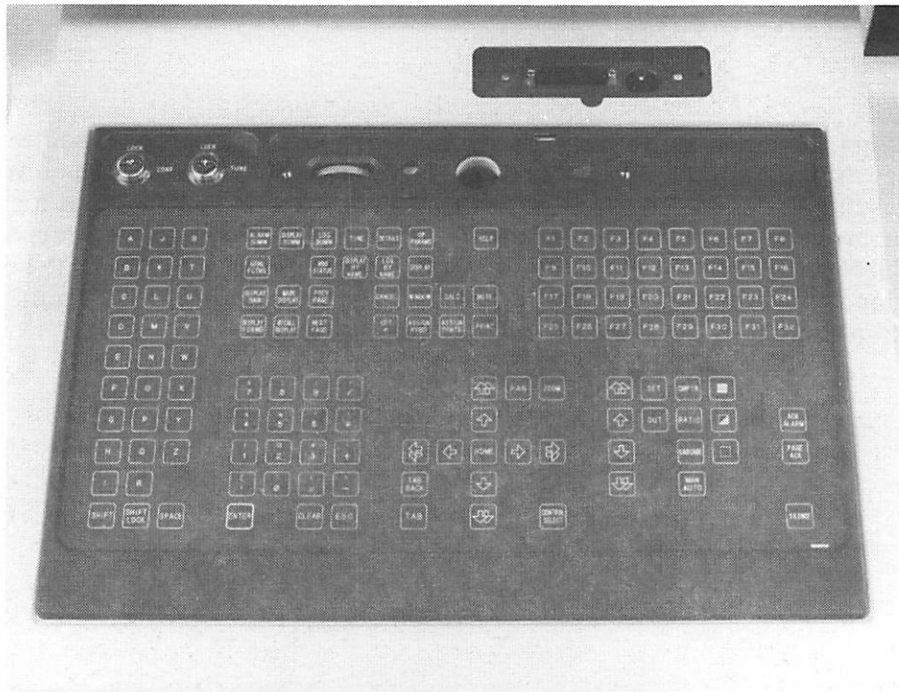

Figure A-1. Membrane Keyboard

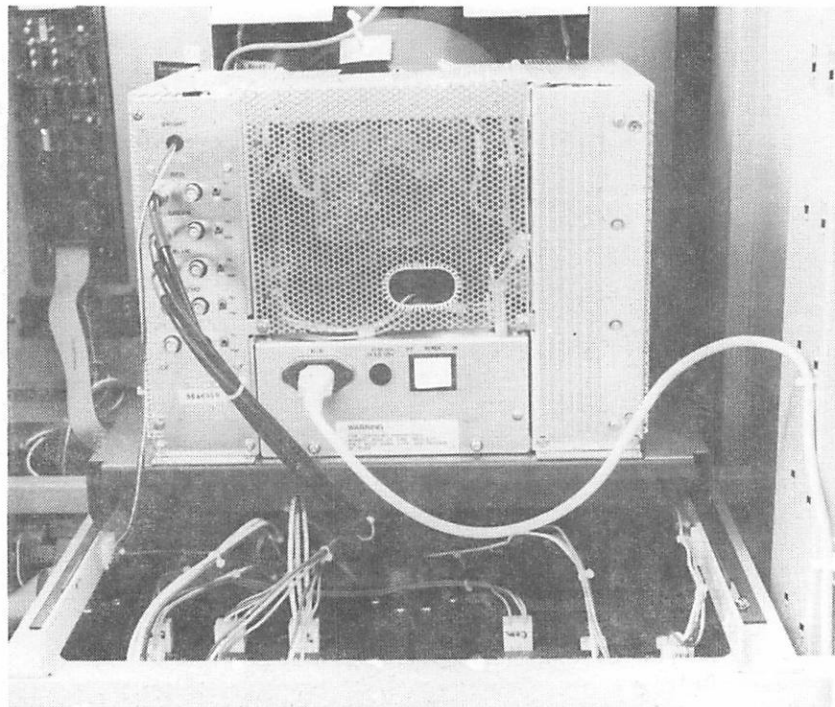
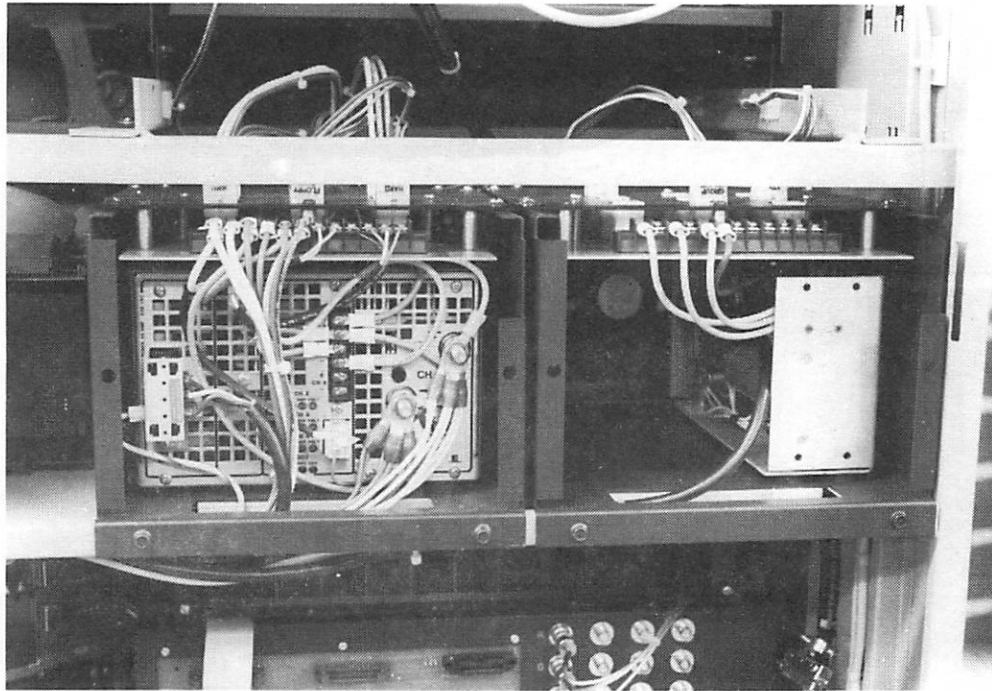
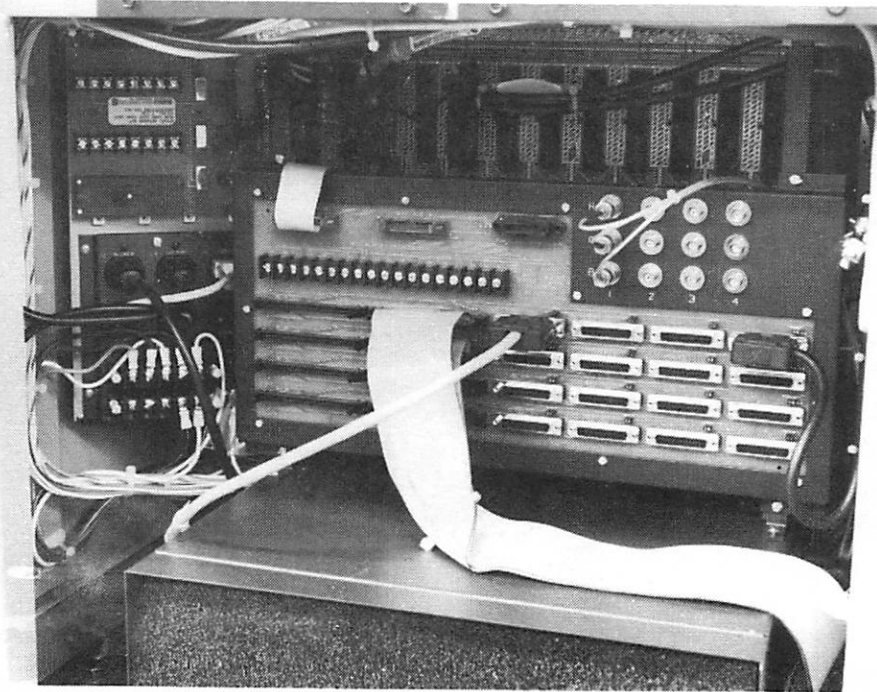

Figure A-2. NMCS02 Rear CRT Enclosure





*Figure A-3. NMCS02 Power Supplies*



*Figure A-4. NMCS02 I/O and AC Distribution Board*

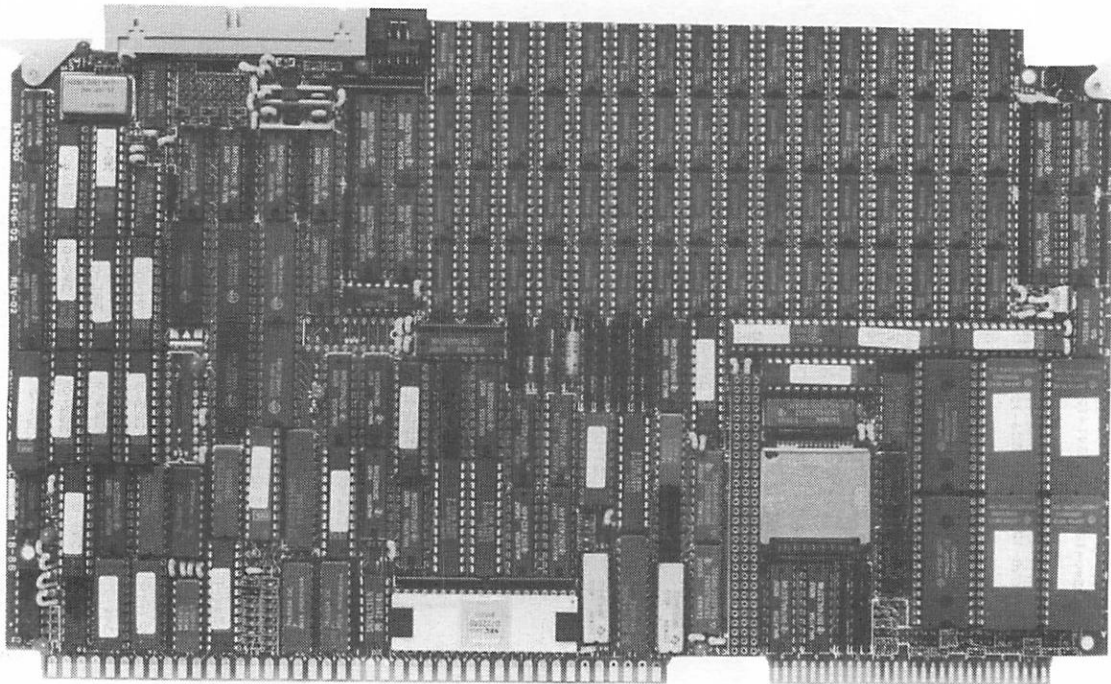

Figure A-5. Color Graphics Card

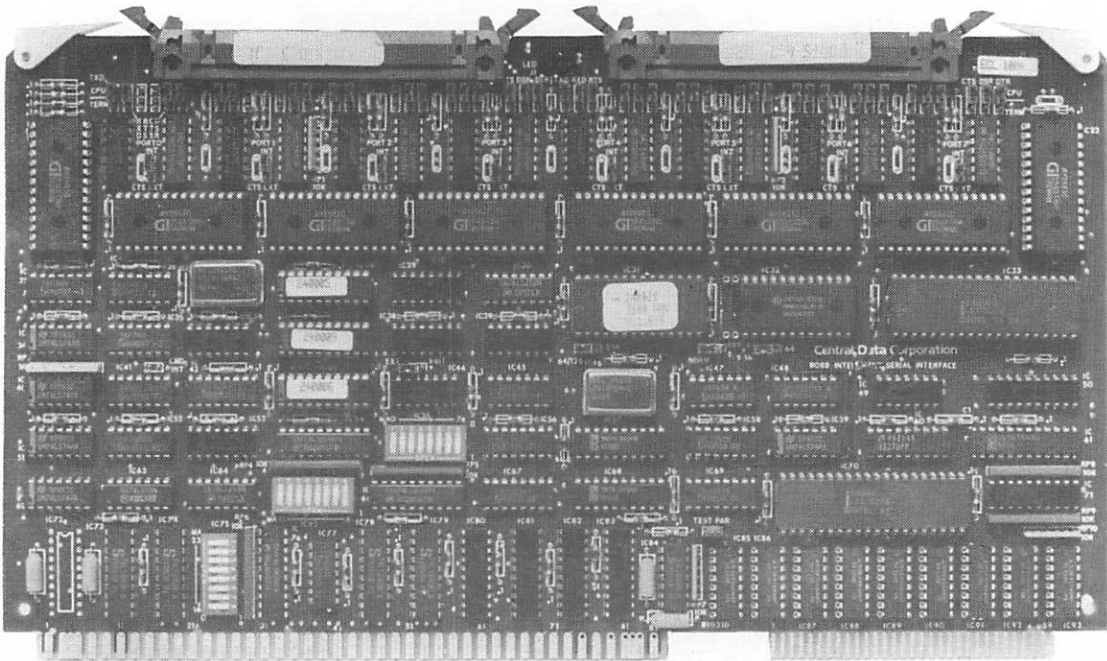

Figure A-6. Intelligent Serial Interface Card

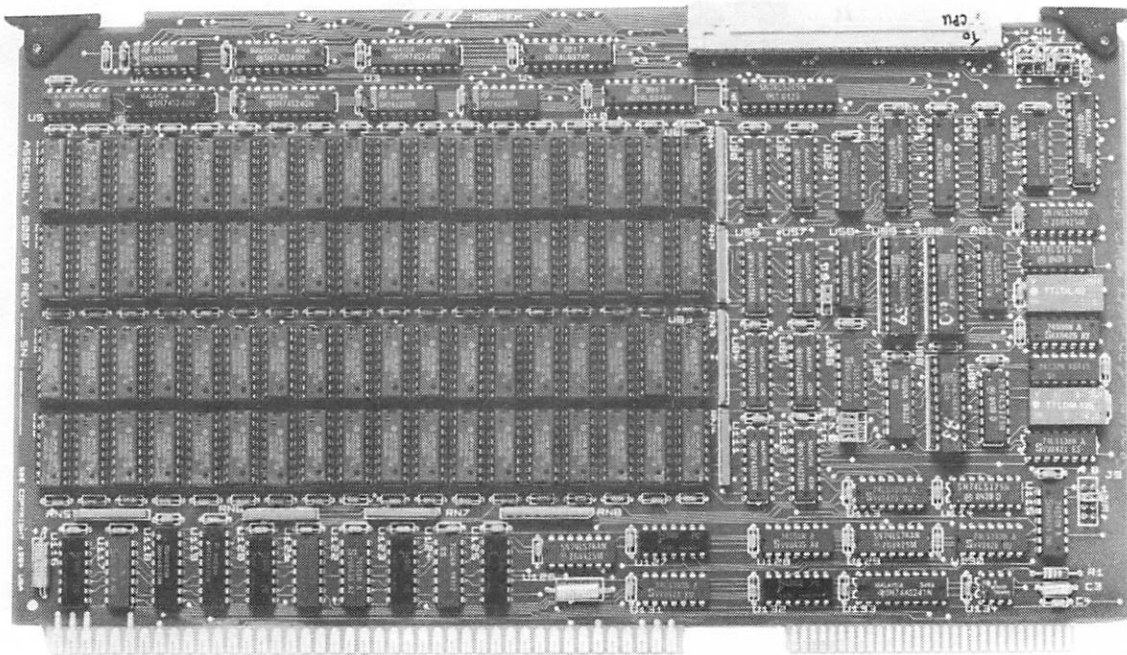

Figure A-7. Local Memory Card

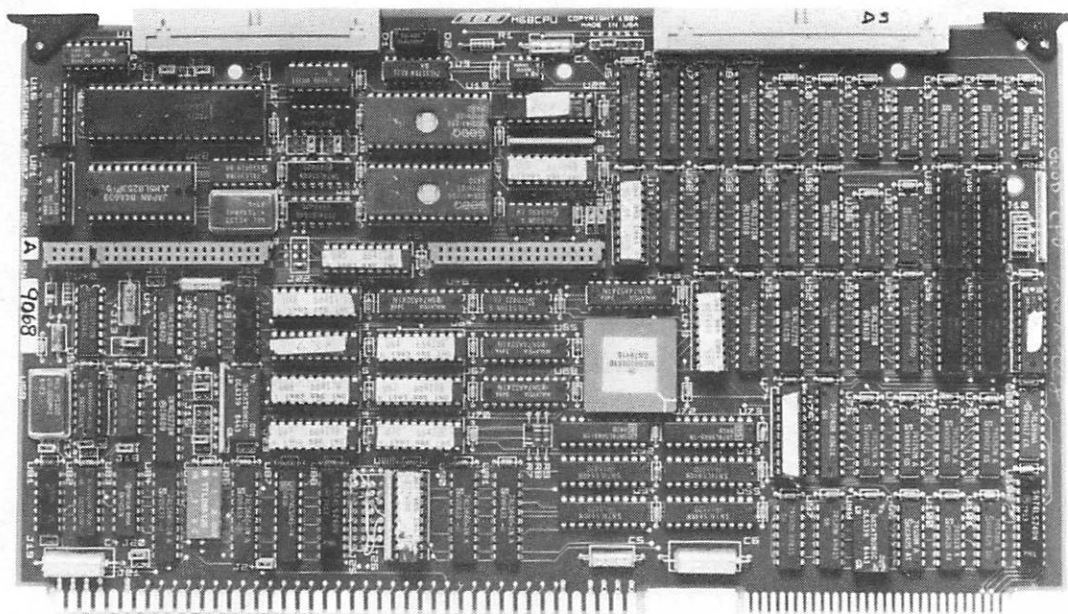

Figure A-8. M68CPU Card used for CPU #2, Application Processor, Disk Server (w/o SASI and SCSI Cards), and CPU #1 (w/o Clock Card)

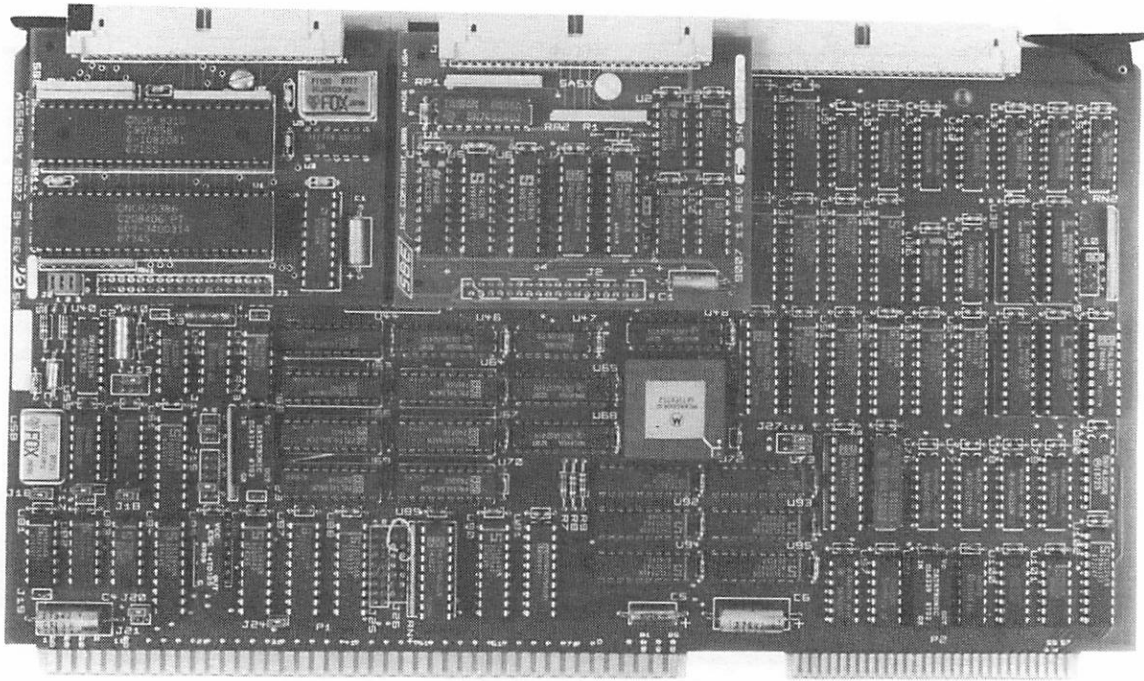

Figure A-9. Disk Server Card

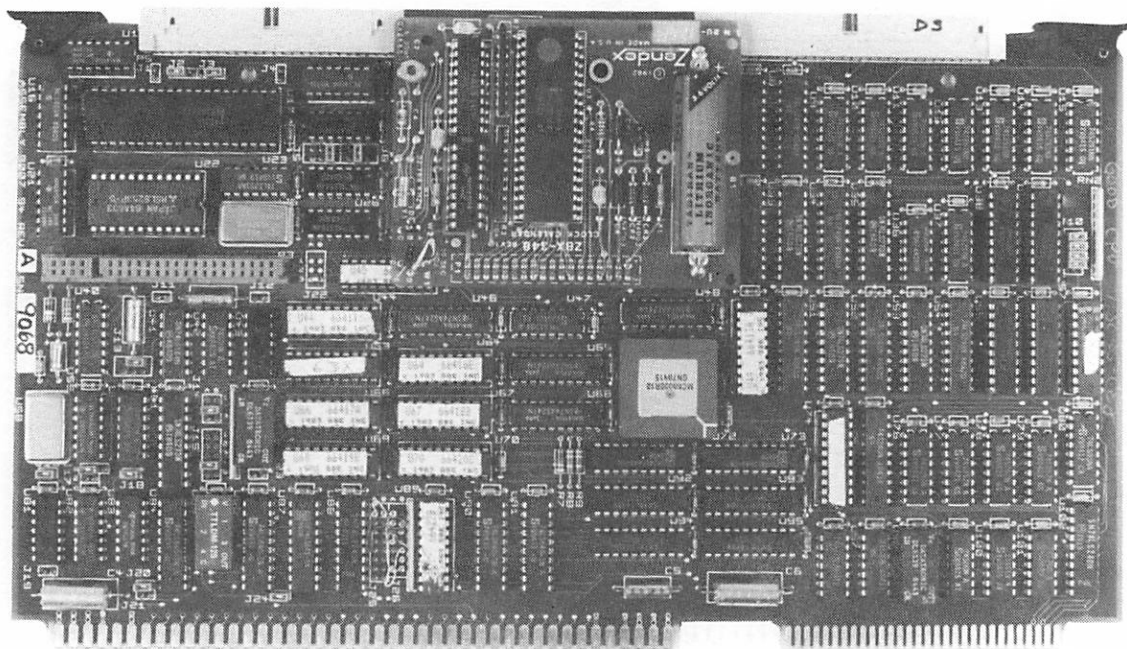

Figure A-10. CPU #1 Card

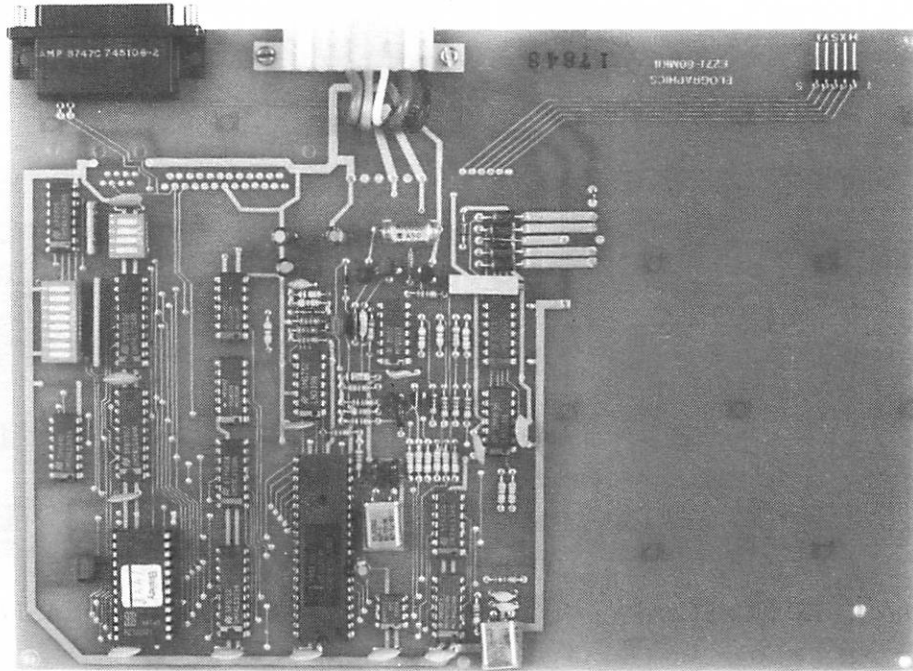

Figure A-11. Touch Screen Controller Card - I.D. Number E271-60MKII

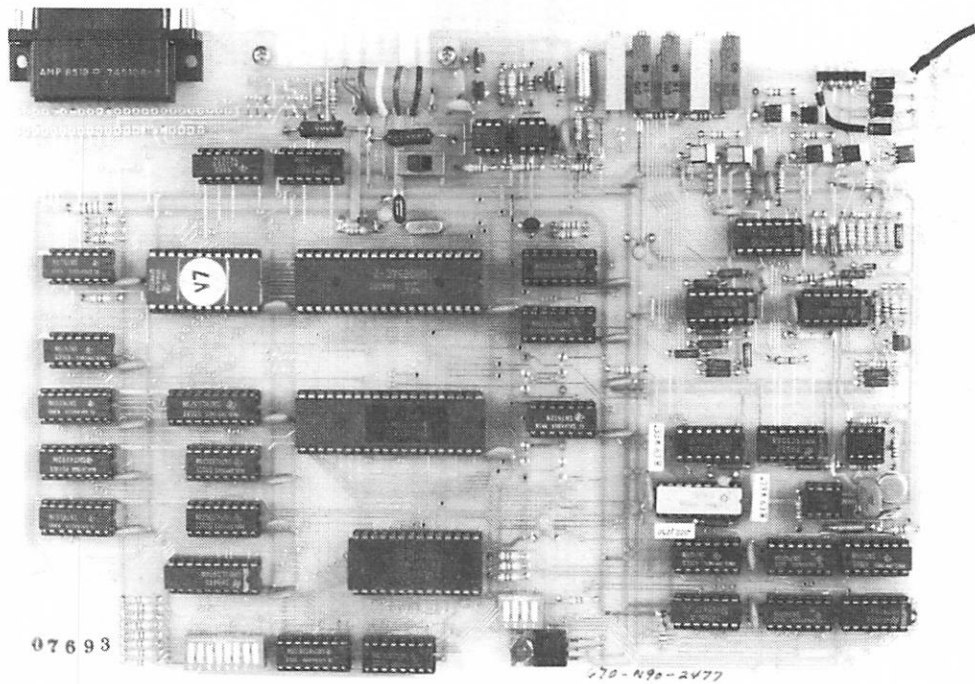

Figure A-12. Touch Screen Controller Card - I.D. Number E271-60

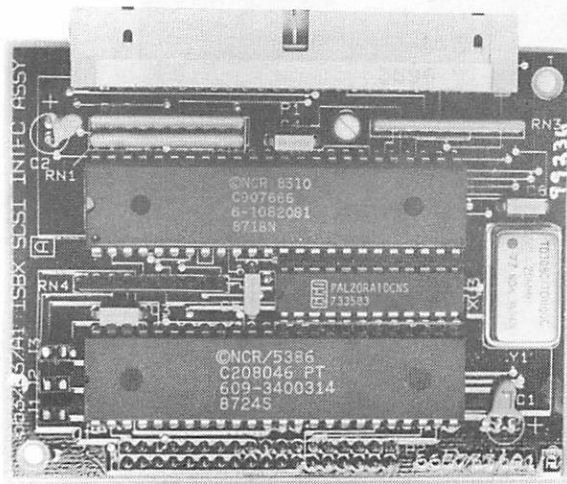

Figure A-13. SCSI Card

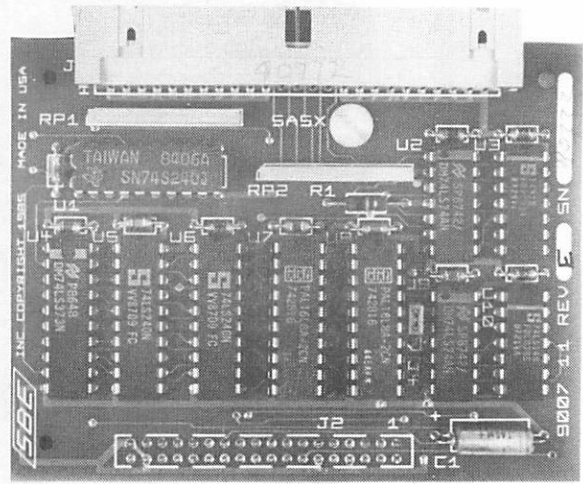

Figure A-14. SASI Card

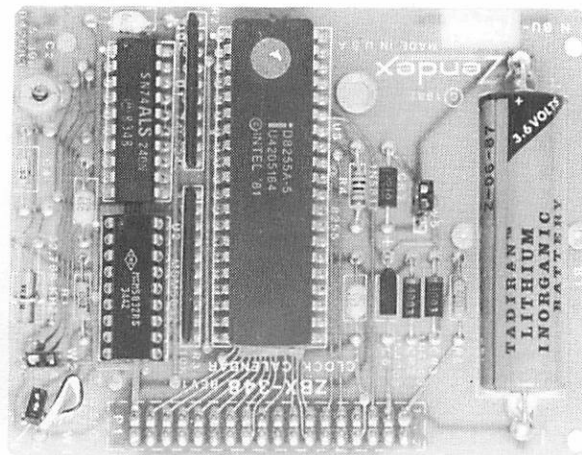

Figure A-15. Clock Calendar Card

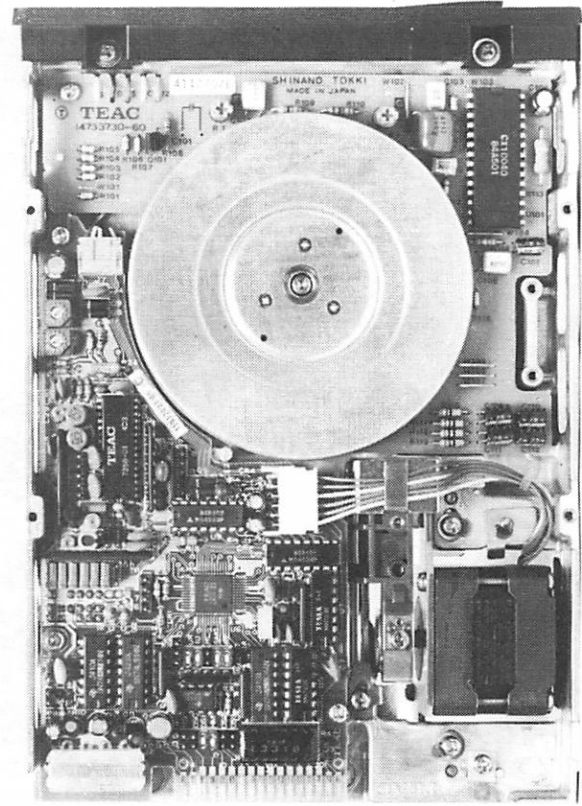
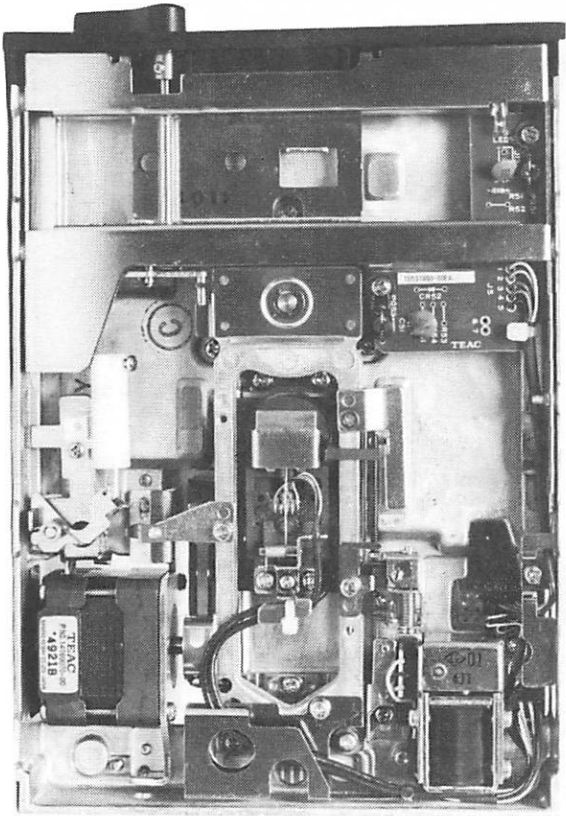

Figure A-16. TEAC FD-55GF-60-U Floppy Drive

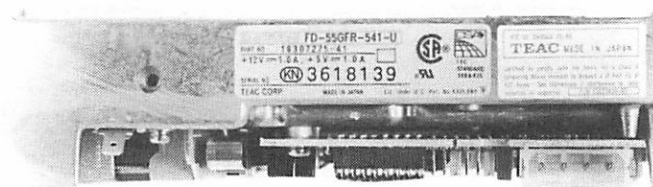
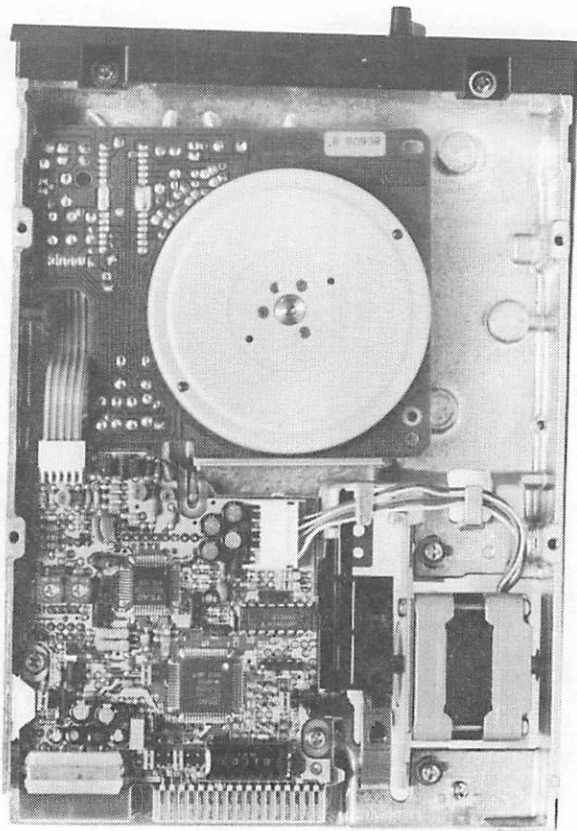

Figure A-17. TEAC FD-55GFR-541-U Floppy Drive



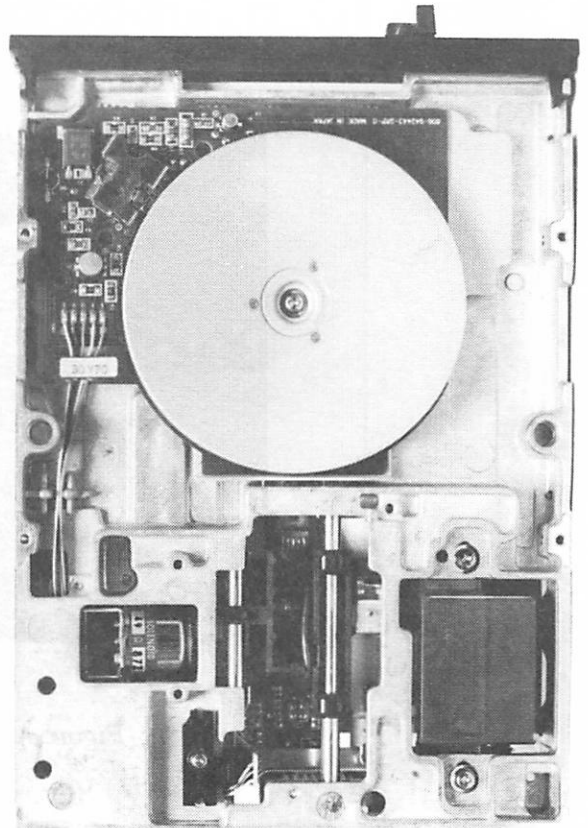
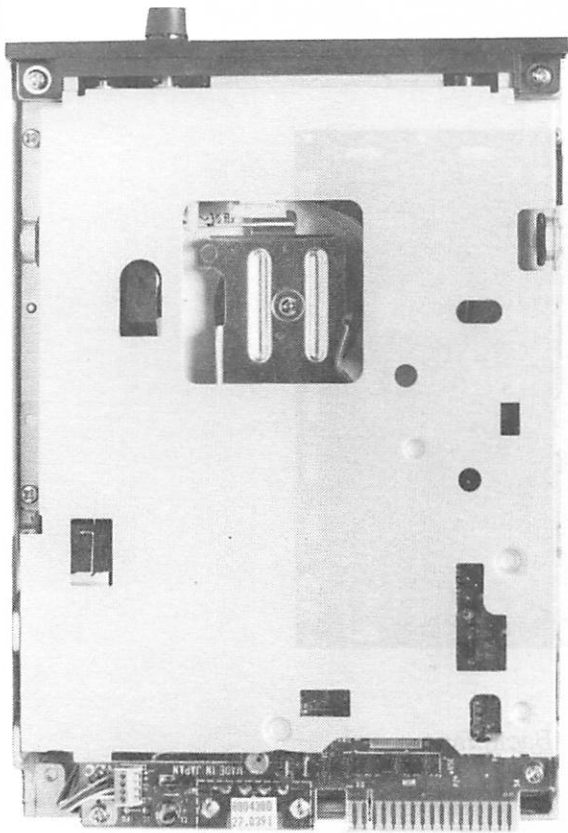

Figure A-18. NEC FD1157C Floppy Drive

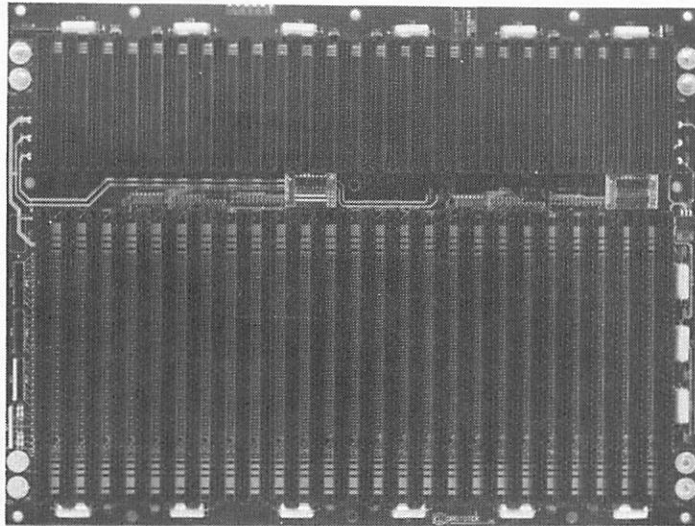

Figure A-19. Multibus Backplane

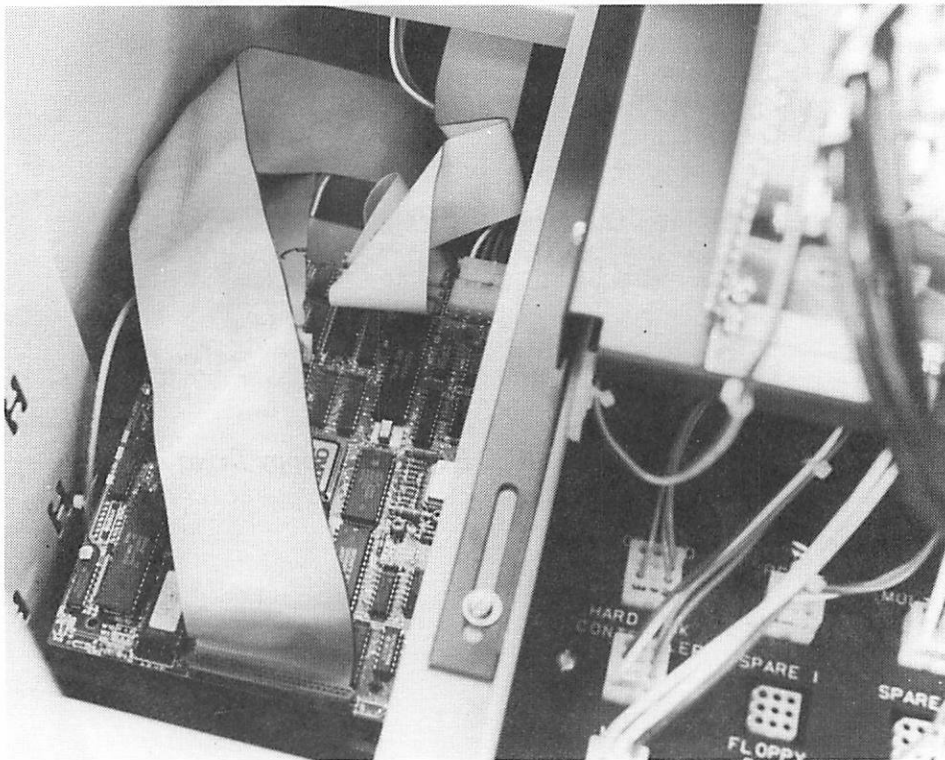

Figure A-20. Hard Disk Controller Card

For a complete list of licensees, representatives and affiliates in over 50 countries worldwide, contact . . .

**Bailey Controls Company**

29801 Euclid Avenue, Wickliffe, Ohio 44092 • (216) 585-8500  
Telex: 980621 • Telefax: (216) 585-8756 or (216) 943-4609